

# SHARP SERVICE MANUAL

CODE : 00ZAR5618/S1E

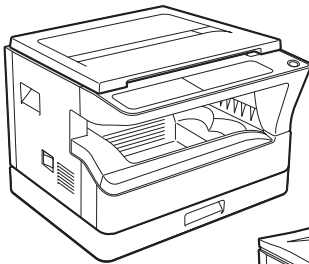

AR-5618S/5620S  
AR-5618N

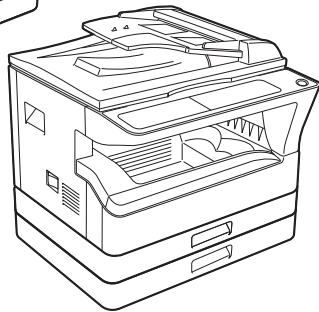

AR-5620N/5623N

## DIGITAL MULTIFUNCTIONAL SYSTEM

### AR-5618S/5620S MODEL AR-5618N/5620N/5623N

#### CONTENTS

[ 1 ] GENERAL .....	1 - 1
[ 2 ] CONFIGURATION .....	2 - 1
[ 3 ] SPECIFICATIONS .....	3 - 1
[ 4 ] CONSUMABLE PARTS .....	4 - 1
[ 5 ] EXTERNAL VIEWS AND INTERNAL STRUCTURES .....	5 - 1
[ 6 ] ADJUSTMENTS .....	6 - 1
[ 7 ] SIMULATIONS .....	7 - 1
[ 8 ] TROUBLE CODE LIST .....	8 - 1
[ 9 ] MAINTENANCE .....	9 - 1
[10] DISASSEMBLY AND ASSEMBLY .....	10 - 1
[11] OPERATIONAL DESCRIPTIONS .....	11 - 1
[12] FLASH ROM VERSION UP PROCEDURE .....	12 - 1
[13] ELECTRICAL SECTION .....	13 - 1

Parts marked with “” are important for maintaining the safety of the set.

Be sure to replace these parts with specified ones for maintaining the safety and performance of the set.

## CAUTION

This product is a class 1 laser product that complies with 21CFR 1040.10 and 1040.11 of the CDRH standard and IEC825. This means that this machine does not produce hazardous laser radiation. The use of controls, adjustments or performance of procedures other than those specified herein may result in hazardous radiation exposure.

This laser radiation is not a danger to the skin, but when an exact focusing of the laser beam is achieved on the eye's retina, there is the danger of spot damage to the retina.

The following cautions must be observed to avoid exposure of the laser beam to your eyes at the time of servicing.

- 1) When a problem in the laser optical unit has occurred, the whole optical unit must be exchanged as a unit, not as individual parts.
- 2) Do not look into the machine with the main switch turned on after removing the developer unit, toner cartridge, and drum cartridge.
- 3) Do not look into the laser beam exposure slit of the laser optical unit with the connector connected when removing and installing the optical system.
- 4) The middle frame contains the safety interlock switch.

Do not defeat the safety interlock by inserting wedges or other items into the switch slot.

## Warning!

This product is a class A product.

If it is operated in households, offices or similar surroundings, it can produce radio interferences at other appliances, so that the user has to take adequate countermeasures.

## VAROITUS!

LAITTEEN KÄYTTÄMINEN MUULLA KUIN TÄSSÄ KÄYTTÖOHJEESSA MAINITULLA TAVALLA SAATTAA ALTISTAA KÄYTTÄJÄN TURVALLISUUSLUOKAN 1 YLITTÄVÄLLE NÄKYMÄTTÖMÄLLE LASERSÄTEILYLLE.

## VARNING

OM APPARATEN ANVÄNDS PÅ ANNAT SÄTT ÄN I DENNA BRUKSANVISNING SPECIFICERATS, KAN ANVÄNDAREN UTSÄTTAS FÖR OSYNLIG LASERSTRÅLNING, SOM ÖVERSKRIDER GRÄNSEN FÖR LASERKLASS 1.

## CAUTION

INVISIBLE LASER RADIATION,  
WHEN OPEN AND INTERLOCKS DEFEATED. AVOID  
EXPOSURE TO BEAM.

## VORSICHT

UNSICHTBARE LASERSTRAHLUNG,  
WENN ABDECKUNG GEÖFFNET UND  
SICHERHEITSVERRIEGELUNG ÜBERBRÜCKT. NICHT  
DEM STRAHL AUSSETZEN.

## VARO!

AVATTAESSA JA SUOJALUKITUS OHITETTAESSA OLET  
ALTTIINA NÄKYMÄTTÖMÄLLE LASERSÄTEILYLLE ÄLÄ  
KATSO SÄTEESEEN.

## ADVARSEL

USYNLIG LASERSTRÅLNING VED ÅBNING, NÅR  
SIKKERHEDSBRYDERE ER UDE AF  
FUNKTION. UND GÅ UD SÆTTELSE FOR  
STRÅLNING.

## VARNING!

OSYNLIG LASERSTRÅLNING NÄR DENNA DEL ÄR  
ÖPPNAD OCH SPÄRREN ÄR URKOPPLAD. BETRakta EJ  
STRÅLEN. – STRÅLEN ÄR FARLIG.

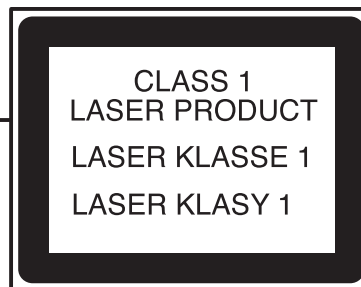
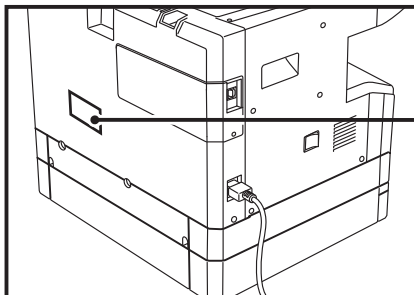

Disconnect the AC cord before servicing the unit.

LASER WAVE - LENGTH :  $795 \pm 15$ nm  
Pulse times : 0.481ms/6mm  
Out put power : 5mW

#### CAUTION FOR BATTERY REPLACEMENT

- (Danish)                   ADVARSEL !  
Lithiumbatteri – Eksplosionsfare ved fejlagtig håndtering.  
Udskiftning må kun ske med batteri  
af samme fabrikat og type.  
Levér det brugte batteri tilbage til leverandoren.
- (English)                   Caution !  
Danger of explosion if battery is incorrectly replaced.  
Replace only with the same or equivalent type  
recommended by the manufacturer.  
Dispose of used batteries according to manufacturer's instructions.
- (Finnish)                   VAROITUS  
Paristo voi räjähtää, jos se on virheellisesti asennettu.  
Vaihda paristo ainoastaan laitevalmistajan suosittelemaan  
tyyppiin. Hävitä käytetty paristo valmistajan ohjeiden  
mukaisesti.
- (French)                   ATTENTION  
Il y a danger d'explosion s' il y a remplacement incorrect  
de la batterie. Remplacer uniquement avec une batterie du  
même type ou d'un type équivalent recommandé par  
le constructeur.  
Mettre au rebut les batteries usagées conformément aux  
instructions du fabricant.
- (Swedish)                   VARNING  
Explosionsfara vid felaktigt batteribyte.  
Använd samma batterityp eller en ekvivalent  
typ som rekommenderas av apparattillverkaren.  
Kassera använt batteri enligt fabrikantens  
instruktion.
- (German)                   Achtung  
Explosionsgefahr bei Verwendung inkorrekt er Batterien.  
Als Ersatzbatterien dürfen nur Batterien vom gleichen Typ oder  
vom Hersteller empfohlene Batterien verwendet werden.  
Entsorgung der gebrauchten Batterien nur nach den vom  
Hersteller angegebenen Anweisungen.

#### CAUTION FOR BATTERY DISPOSAL

- (For USA,CANADA)  
Contains lithium-ion battery. Must be disposed of properly.  
Remove the battery from the product and contact  
federal or state environmental  
agencies for information on recycling and disposal options.

# CONTENTS

## [1] GENERAL

- 1. Note for servicing . . . . . 1 - 1

## [2] CONFIGURATION

- 1. System Configurations . . . . . 2 - 1

## [3] SPECIFICATIONS

- 1. Copy mode . . . . . 3 - 1

## [4] CONSUMABLE PARTS

- 1. Supply system table . . . . . 4 - 1
- 2. Environmental conditions . . . . . 4 - 2
- 3. Production number identification . . . . . 4 - 3

## [5] EXTERNAL VIEWS AND INTERNAL STRUCTURES

- 1. Appearance . . . . . 5 - 1
- 2. Internal . . . . . 5 - 1
- 3. Operation Section . . . . . 5 - 2
- 4. Motor, solenoid, clutch . . . . . 5 - 3
- 5. Sensor, switch . . . . . 5 - 4
- 6. PWB unit . . . . . 5 - 5
- 7. Cross sectional view . . . . . 5 - 6

## [6] ADJUSTMENTS

- 1. Adjustment item list . . . . . 6 - 1
- 2. Copier adjustment . . . . . 6 - 1

## [7] SIMULATIONS

- 1. Entering the simulation mode . . . . . 7 - 1
- 2. Canceling the simulation mode . . . . . 7 - 1
- 3. List of simulations . . . . . 7 - 1
- 4. Contents of simulations . . . . . 7 - 3

## [8] TROUBLE CODE LIST

- 1. Trouble code list . . . . . 8 - 1
- 2. Details of trouble codes . . . . . 8 - 1

## [9] MAINTENANCE

- 1. Maintenance table . . . . . 9 - 1
- 2. Maintenance display system . . . . . 9 - 2
- 3. Note for replacement of consumable parts . . . . . 9 - 2

## [10] DISASSEMBLY AND ASSEMBLY

- 1. High voltage section/Duplex transport section . . . . . 10 - 1
- 2. Optical section . . . . . 10 - 2
- 3. Fusing section . . . . . 10 - 4
- 4. Paper exit section . . . . . 10 - 7
- 5. MCU/NIC . . . . . 10 - 9
- 6. Optical frame unit . . . . . 10 - 9
- 7. LSU . . . . . 10 - 10
- 8. Tray paper feed section/Paper transport section . . . . . 10 - 10
- 9. Bypass tray section . . . . . 10 - 12
- 10. Power section . . . . . 10 - 14
- 11. Developing section . . . . . 10 - 15
- 12. Process section . . . . . 10 - 16
- 13. Others . . . . . 10 - 16

## [11] OPERATIONAL DESCRIPTIONS

- 1. Paper feed operation . . . . . 11 - 1

## [12] FLASH ROM VERSION UP PROCEDURE

- 1. Preparation . . . . . 12 - 1
- 2. Download procedure . . . . . 12 - 1
- 3. Installation procedure . . . . . 12 - 2
- 4. AR-5618N/5620N/5623N download procedures . . . . . 12 - 5

## [13] ELECTRICAL SECTION

- 1. Block diagram . . . . . 13 - 1
- 2. Actual wiring diagram . . . . . 13 - 2

# [1] GENERAL

## 1. Note for servicing

### Pictogram

The label (⚠ ⚠) in the fusing area of the machine indicates the following:

- ⚠ : Caution, risk of danger
- ⚠ : Caution, hot surface

### A. Warning for servicing

- The fusing area is hot. Exercise care in this area when removing misfed paper.
- Do not disassemble the laser unit. Do not insert a reflective material such as a screwdriver in the laser beam path. It may damage eyes by reflection of laser beams.

### B. Cautions for servicing

- Do not switch the machine rapidly on and off. After turning the machine off, wait 10 to 15 seconds before turning it back on.
- Machine power must be turned off before installing any supplies.
- Place the machine on a firm, level surface.
- Do not install the machine in a humid or dusty location.
- When the machine is not used for a long time, for example, during prolonged holidays, turn the power switch off and remove the power cord from the outlet.
- When moving the machine, be sure to turn the power switch off and remove the power cord from the outlet.
- Do not cover the machine with a dust cover, cloth or plastic film while the power is on. Doing so may prevent heat dissipation, damaging the machine.
- Use of controls or adjustments or performance of procedures other than those specified herein may result in hazardous laser radiation exposure.
- The socket-outlet shall be installed near the machine and shall be easily accessible.

### C. Note for installation place

Improper installation may damage the machine. Please note the following during initial installation and whenever the machine is moved.

Caution : If the machine is moved from a cool place to a warm place, condensation may form inside the machine. Operation in this condition will cause poor copy quality and malfunctions. Leave the machine at room temperature for at least 2 hours before use.

**Do not install your machine in areas that are:**

- damp, humid, or very dusty

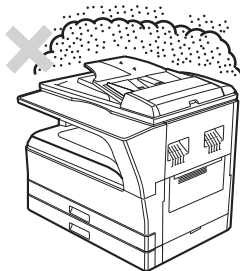

- poorly ventilated

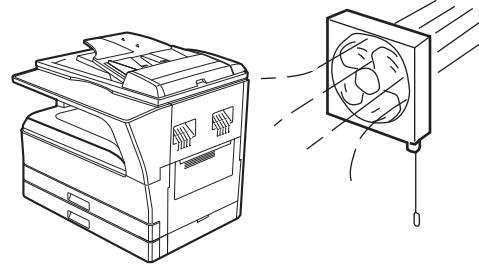

- exposed to direct sunlight

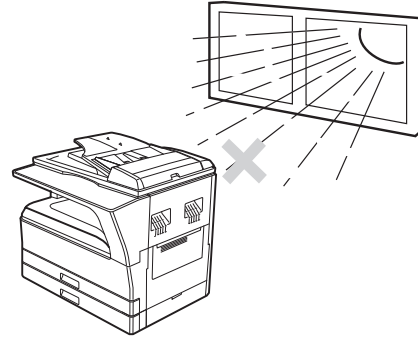

- subject to extreme temperature or humidity changes, e.g., near an air conditioner or heater.

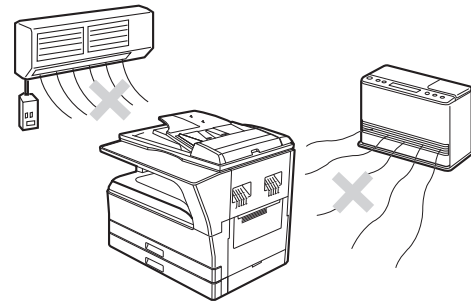

The machine should be installed near an accessible power outlet for easy connection and disconnection.

Be sure to connect the power cord only to a power outlet that meets the specified voltage and current requirements. Also make certain the outlet is properly grounded.

Note : Connect the machine to a power outlet which is not used for other electric appliances. If a lighting fixture is connected to the same outlet, the light may flicker.

Be sure to allow the required space around the machine for servicing and proper ventilation.

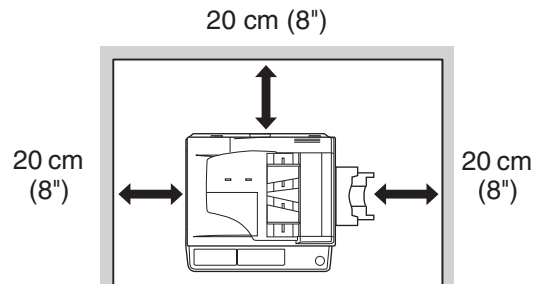

## [2] CONFIGURATION

### 1. System Configurations

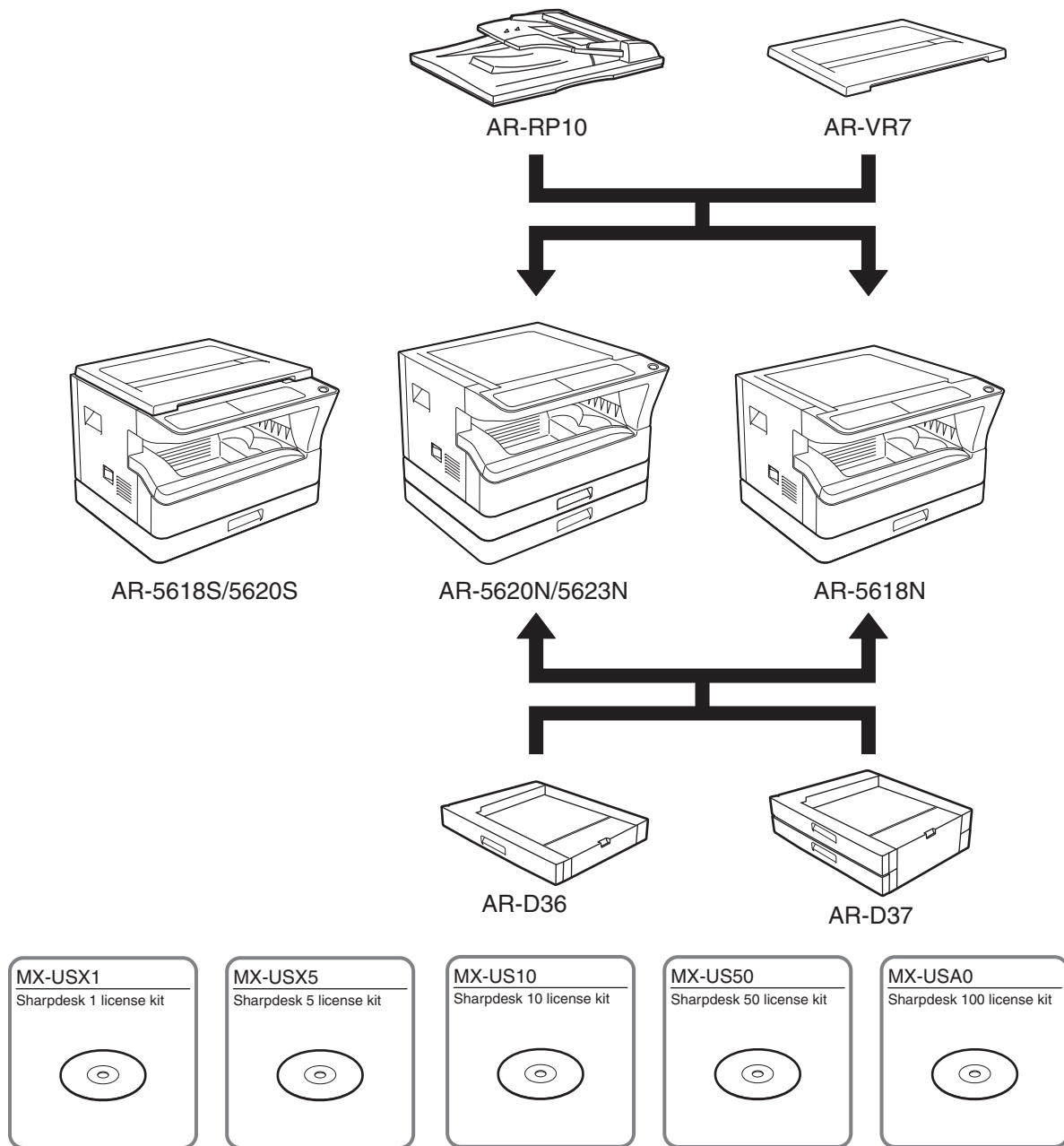

Option	Model	AR-5618S/5620S	AR-5618N/5620N/5623N
AR-RP10	Reversing single pass feeder (RSPF)	X	O
AR-D36	250-sheet paper feed unit	X	O
AR-D37	2x250-sheet paper feed unit	X	O
AR-VR7	DOCUMENT COVER	STD	O
MX-USX1	SHARPDESK 1 LICENSE KIT	X	O
MX-USX5	SHARPDESK 5 LICENSE KIT	X	O
MX-US10	SHARPDESK 10 LICENSE KIT	X	O
MX-US50	SHARPDESK 50 LICENSE KIT	X	O
MX-USA0	SHARPDESK 100 LICENSE KIT	X	O

STD: Standard    O: Option installation enable    X: Option installation disable

# [3] SPECIFICATIONS

## 1. Copy mode

### A. Type

Type	Desk-top
Paper exit	center tray / internal

### B. Machine composition

AR-5618S AR-5618N	18-CPM multi function model
AR-5620S AR-5620N	20-CPM multi function model
AR-5623N	23-CPM multi function model

### (1) Option

Machine	Model	
250-sheet paper feed unit	AR-D36	AR-5618N/5620N/5623N
2x250-sheet paper feed unit	AR-D37	
RSPF	AR-RP10	AR-5618N/5620N/5623N

### C. Copy speed

#### (1) Engine speed (ppm)

Paper size	AR-5623N	AR-5620S AR-5620N	AR-5618S AR-5618N
A4/8.5" x 11"	23ppm	20ppm	18ppm
A4R/ 8.5" x 11"R	15/16ppm	14/15ppm	14/15ppm
A5/5.5"x8.5"	23ppm	20ppm	18ppm
B5/16K	23ppm	20ppm	18ppm
B5R/16KR	18/16ppm	16/15ppm	16/15ppm
8.5x13"	13ppm	12ppm	12ppm
B4/8.5"x14	13ppm	12ppm	12ppm
A3/11"x17"/ 8K	12/11/12ppm	11/10/11ppm	11/10/11ppm

#### (2) Engine performance when printing

Paper size	23cpm machine	20cpm machine	18cpm machine
ROPM OFF*1	12ppm or more	12ppm or more	12ppm or more
ROPM ON	23ppm	20ppm	18ppm

\*1:S model is contained.

#### (3) Document replacement speed (Copy mode)

Copy mode	AR-5623N	AR-5620S AR-5620N	AR-5618S AR-5618N
S to S	20cpm (87%)	20cpm (100%)	18cpm (100%)

S to S : A4/8.5" x 11" document 11 sheets, copy 1 set

#### (4) Job efficiency

Copy mode	AR-5623N	AR-5620S AR-5620N	AR-5618S AR-5618N
S to S	18cpm (78%)	18cpm (90%)	15cpm (94%)
S to D	10cpm (43%)	10cpm (50%)	10cpm (63%)
D to D	10cpm (43%)	10cpm (50%)	10cpm (63%)

S to S : A4/8.5"x11" document 10 sheets, copy 5 sets

S to D : A4/8.5"x11" document 10 sheets, copy 5 sets

D to D : A4/8.5"x11" document 10 sheets (20 pages), copy 5 sets

Note : The temperature at the both end portion of Heat roller may rise too high, depending on the paper to use (and condition) such as continuous printing of small size paper.

In order to prevent this situation, output (of paper) is interrupted to cool down the roller when the thermistor at the end portion detects higher temperature than the specified temperature.

While it is interrupted, Power Save Indicator lamp blinks similarly as at the normal Warm-up.

### (5) First copy time

Tray	18/20cpm machine	23cpm machine
1st tray	7.2 sec or less	5.9 sec or less

AE mode, A4/Letter, single surface copy with OC, in polygon ready state

### D. Document

Max. document size	A3, 11" X 17"
Document reference position	Left center
Detection (Platen)	None

### E. Paper feed

#### (1) Paper feed section details

Item	1st tray	2nd tray	Bypass tray
Paper capacity	250 sheets	250 sheets	100 sheets
Paper size detection	No (Paper size is set with the operation panel.)		
Paper type setting	No	No	No (Heavy paper setting is enabled.)
Paper size changing method	The paper guide is set by the user.		
Default paper size when shipping	AB series	A4	A4
	Inch series	8 1/2" x11"	8 1/2" x11"
Remaining paper quantity detection	Only empty detection available		

#### (2) Feedable paper

Paper size	1st tray	2nd tray	Bypass tray
A3	Yes	Yes	Yes
B4	Yes	Yes	Yes
A4	Yes	Yes	Yes
A4-R	Yes	Yes	Yes
B5	Yes	Yes	Yes
B5R	Yes	Yes	Yes
A5	Yes	N/A	Yes
A5R	N/A	N/A	Yes
A6R	N/A	N/A	Yes
B6R	N/A	N/A	Yes
Ledger 11 x 17 in	Yes	Yes	Yes
Legal 8.5x14in.	Yes	Yes	Yes
Foolscap 8.5 x 13 in	Yes	Yes	Yes
Letter 11x8.5in	Yes	Yes	Yes
Letter-R 8.5x11in	Yes	Yes	Yes
Executive-R 7.25x10.5in.	N/A	N/A	Yes
Invoice 8.5x5.5 in.	Yes	N/A	Yes
Invoice-R 5.5x8.5 in	N/A	N/A	Yes
8K	Yes	Yes	Yes
16K	Yes	Yes	Yes
16KR	Yes	Yes	Yes
COM10	N/A	N/A	Yes

### (3)Types of feedable paper

Types of paper		1st tray	2nd tray	Bypass tray
Thin paper	56-59g/m <sup>2</sup> 15-15.9lbs	Yes	Yes	Yes
Plain paper	60-90g/m <sup>2</sup> 16-24lbs	Yes	Yes	Yes
Heavy paper	91-105g/m <sup>2</sup> 16-24lbs	N/A	N/A	Yes (Multi paper feed enable)
Heavy paper	106-128g/m <sup>2</sup> 24.1-33.5lbs	N/A	N/A	Yes (A4 or less) (Multi paper feed enable)
Heavy paper	129-200g/m <sup>2</sup> 33.6-53.2lbs	N/A	N/A	Yes (A4 or less) (Only single paper feed)
Heavy paper	201-256g/m <sup>2</sup> 53.3-68lbs	N/A	N/A	N/A
Envelope	75-90g/m <sup>2</sup> 20-24lbs	N/A	N/A	Yes
Postcard		N/A	N/A	Yes
OHP film		N/A	N/A	Yes
Label sheet		N/A	N/A	Yes
Tab paper 20		N/A	N/A	N/A

### F. Multi copy

Max. number of multi copy	999 sheets
---------------------------	------------

### G. Warm-up time

Warm-up time	25 seconds or less
Pre-heat	Available
Jam recovery	Within 25 sec

### H. Copy magnification ratio

Fixed magnification ratio	AB system: 200, 141, 122, 115, 100, 86, 81, 70, 50%
	Inch system: 200, 141, 129, 121, 100, 95, 77, 64, 50%
Zooming	25 ~ 400% RSPF (50 ~ 200%)
Independent zooming (vertical)	Available (25 ~ 400%) RSPF (50 ~ 200%)
Independent zooming (horizontal)	Available (25 ~ 400%) RSPF (50 ~ 200%)

### I. Copy density

Density mode	Auto / Text / Photo
No. of manual adjustment	5 steps (Text / Photo)
Resolution	Writing: 600 x 600dpi Reading: 400 (main) x 600 (sub) (PHOTO mode) 400 (main) x 600 (sub) (AUTO exposure mode) 400 (main) x 600 (sub) dpi (TEXT mode)
Gradation	Reading: 256 gradations Writing: Binary

### J. Void width

Void area	Lead edge 1 ~ 4mm		
	Rear edge 4mm or less		
Image loss	Total of both sides: 6mm or less		
	OC	Same size	4.0mm or less
	RSPF	Same size	4.5mm or less

### K. Auto duplex

Standard/Option	Standard provision (AR-5618N/5620N/5623N only) (D → D / D → S enable only when RSPF is installed) Not available for AR-5618S/5620S
-----------------	--

### L. Paper exit / finishing

Paper exit section capacity	Face down 250 sheets
Full detection	None
Finishing	None
Electronic sort capacity	A4/ 8.5" x 11" standard document (6% coverage) 80 sheets
Offset function	None
Staple function	None

### M. Additional functions

	AR-5618S/5620S	AR-5618N/5620N/5623N
APS		○
AMS		○
Auto tray switching	X	○
Memory copy		○
Rotation copy		○
E-sort (Sorting function)	X	○ Single surface, A4, 6% document, Max. 80 sheets
E-sort (Grouping function)	X	○
Rotation sort		X
Prevention of sky shot		X
Independent zooming		○
1 set 2 copy		○
	SPF: Disable OC: Enlargement is disable.	
Binding margin	X	○
Edge erase	X	Default AB series: 10mm (5, 10, 15, 20mm) Inch series: 1/2 inch (1/4, 1/2, 3/4, 1 inch)
Center erase	X	
Black/white reverse		X
2in1/4in1	X	○
Offset		X
Preheating		○ The conditions are set by the system setting.
Auto shut-off		○ The conditions are set by the system setting.
System setting		○
Counter		○ (1) Copy total (2) Print total (3) Scan (Except S model) (4) Toner residual quantity
Coin vendor support		○ (Need to I/F service parts.)
Auditor support		○ (Need to I/F service parts.)
Duplex	X	○
Toner save		○ (Set according to the destination)
Account control		○ (Copy: 20 Dept.)

○ : Available X : Not available

## N. Other specifications

Photoconductor type	OPC (Organic Photo Conductor)
Photoconductor drum dia.	30mm
Copy lamp	WhiteCCFL
Developing system	Dry 2-component magnetic brush development
Charging system	Saw teeth charging
Transfer system	(+) DC corotron
Separation system	(-) DC corotron
Fusing system	Heat roller
Cleaning system	Contact blade

## O. Package form

Body	Body / Accessories
------	--------------------

## P. External view

	S model	N model
External dimensions (With the bypass tray closed)	591mm(W) x 550mm(D)	
Occupying area (With the bypass tray opened)	883mm(W) x 550mm(D)	
Weight (Excluding developer)	28.6kg	1 stage model: 27.8kg 2 stage model: 33.0kg

## Q. Power source

Voltage	100 - 127V 220 - 240V
Frequency	50/60Hz common

## R. Power consumption

Max. power consumption	1200W
------------------------	-------

Average power consumption in operation	Less than 550W
--	----------------

## S. Digital performance

Resolution	Reading	400 x 600dpi (PHOTO mode) 400 x 600dpi (AUTO exposure mode) 400 (main) x 600 (sub) dpi (TEXT mode)
	Writing	600 x 600dpi
Gradation	Reading	256 gradations
	Writing	Binary
Memory	AR-5618S/5620S : 16MB AR-5618N/5620N/5623N : 64MB	
Hard disk	None	

## T. Printing function

### (1) Platform

Item	Content
Support platform	IBM PC/AT compatible machine

### (2) Support OS

OS	Main machine		
	Twain/ Button Manager	SPLC	
Windows	98 / Me	No	No
	NT 4.0 SP5 or later	No	No
	2000	CD-ROM	CD-ROM
	XP	CD-ROM	CD-ROM
	XP x64	CD-ROM	CD-ROM
	Server 2003	No	No
	Server 2003 x64	No	No
	Vista	CD-ROM	CD-ROM
	Vista x64	CD-ROM	CD-ROM
	Server 2008	No	No
	Server 2008 x64	No	No
	Windows 7	CD-ROM	CD-ROM
Windows 7 x64	CD-ROM	CD-ROM	
Mac	9.0-9.2.2	No	No
	X 10.2.8	No	No
	X 10.3.9	No	No
	X 10.4.11	No	No
	X 10.5-10.5.8	No	No
	X 10.6-10.6.4	No	No

### (3) Printer driver function (SPLC)

	Item	SPLC
Support print channel	USB	USB1.1: Windows 2000 / XP / Vista / 7 USB2.0(High-Speed): Windows2000 / XP/ Vista / 7
	LPD	---
	IPP	---
	Raw Port (Port9100)	---
	TCP/IP	Print by TCP/IP port (only for N-model)
	WSD (WS-Print)	Support WSD print (only for N-model)
	BMLinks	---
Print function	Bar-code Font	N/A
	Network Tandem Print	N/A
	Encrypted PDF/PDF/ TIFF/JPEG XPS Direct print	N/A
	Specify files by Web page to print [Web Submit Print]	N/A
	ROPM	Yes
	Multi access support	N/A
	Paper direction setting for duplex printing of letter head paper or punch paper. [Support printing on logo paper (SEGA AOK Company)]	N/A
	Driver Distribution Function	N/A

Item		SPLC
Print function	Form Overlay	N/A
	Support Planet Press	N/A
	Add support font	N/A
	Bonjour for Macintosh environment	N/A
	Layout print	N/A
	Perfect binding	N/A
	Support SharpPrintSystem	N/A
	Support WSD	Yes (only for N-model)
	Rotation in 90 degrees function	N/A
	Printing position adjustment for odd/even pages	N/A
	Print Policy Function	N/A
	Toner Save Mode	N/A
	Support RET	N/A
	Print density adjustment	Yes

#### U. Scanner function (Except for AR-5618S/5620S)

Type	Flat bed scanner
Scan system	Document table/document feed unit
Resolution	75dpi/ 100dpi/ 150dpi/ 200dpi/ 300dpi/ 400dpi/ 600dpi Custum: 50 - 9600dpi
Document	Sheet/Book
Effective scan range	OC/RSPF: about 297(length) x 431(width) mm
Scan speed	OC/RSPF: Color: 1.44msec/line (400dpi) Gray/Scale: 0.48msec/line (400dpi)
Output data	Mono 2 Levels Gray scale: 8bit Full color: Each color RGB 8bit
Scan color	Black & white / binary / Gray scale / Color
Interface	AR-5618N/5620N/5623N: 10/100 base (Internal full speed connection)
Scanner utility	Button Manager
Drop-out color	Yes (Red/Green/Blue/White)
Scanner button	Provided (6)
Supported OS	USB connection:Windows 2000/XP/Vista/7 (AR-5618S/5620S only) network connection:Windows 2000/XP/Vista/7
Void area	Lead edge/rear edge (2.5mm) on the driver side Left/right: 3.0mm

## [4] CONSUMABLE PARTS

### 1. Supply system table

#### A. South and Central America

No.	Name	Product name	Content	Life	Remark	
1	Toner cartridge(Black)	MX-235NT	Toner cartridge Vinyl bag	x1 x1	16K Default is Toner save mode. Life is 19K. (200V series)	Life setting by A4 6% document
2	Developer	MX-235NV	Developer	x1	50K	
3	Drum KIT	AR-205DR	Drum Drum fixing plate	x1 x1	50K	

#### B. Brazil

No.	Name	Product name	Content	Life	Remark	
1	Toner cartridge(Black)	MX-235BT	Toner cartridge Vinyl bag	x1 x1	Default is Toner save mode. Life is 19K.	Life setting by A4 6% document
2	Developer	MX-235NV	Developer	x1	50K	
3	Drum KIT	AR-205DR	Drum Drum fixing plate	x1 x1	50K	

#### C. Europe

No.	Name	Product name	Content	Life	Remark	
1	Toner cartridge(Black)	MX-235GT	Toner cartridge Vinyl bag	x1 x1	16K	Life setting by A4 6% document
2	Developer	MX-235GV	Developer	x1	50K	
3	Drum KIT	AR-205DM	Drum Drum fixing plate	x1 x1	50K	

#### D. Australia/New Zealand

No.	Name	Product name	Content	Life	Remark	
1	Toner cartridge(Black)	MX-235GT	Toner cartridge Vinyl bag	x1 x1	Default is Toner save mode. Life is 19K.	Life setting by A4 6% document
2	Developer	MX-235GV	Developer	x1	50K	
3	Drum KIT	AR-205DM	Drum Drum fixing plate	x1 x1	50K	

#### E. Middle East/Africa/Philippine/Other Distributor (Except Taiwan)

No.	Name	Product name	Content	Life	Remark	
1	Toner cartridge(Black)	MX-235FT	Toner cartridge Vinyl bag	x1 x1	Default is Toner save mode. Life is 19K.	Life setting by A4 6% document
2	Toner cartridge(Black)	MX-236FT	Toner cartridge Vinyl bag	x1 x1	Default is Toner save mode. Life is 19K.	Life setting by A4 6% document
3	Developer	MX-235FV	Developer	x1	50K	
4	Drum KIT	AR-205DR	Drum Drum fixing plate	x1 x1	50K	

#### F. Taiwan

No.	Name	Product name	Content	Life	Remark	
1	Toner cartridge(Black)	MX-235FT	Toner cartridge Vinyl bag	x1 x1	16K	Life setting by A4 6% document
2	Toner cartridge(Black)	MX-236FT	Toner cartridge Vinyl bag	x1 x1	8.4K	Life setting by A4 6% document
3	Developer	MX-235FV	Developer	x1	50K	
4	Drum KIT	AR-205DR	Drum Drum fixing plate	x1 x1	50K	

## G. Asia(Except the above)/Thailand/Hong Kong

No.	Name	Product name	Content	Life	Remark	
1	Toner cartridge(Black)	MX-235AT	Toner cartridge Vinyl bag	x1 x1	Default is Toner save mode. Life is 19K.	Life setting by A4 6% document
2	Toner cartridge(Black)	MX-236AT	Toner cartridge Vinyl bag	x1 x1	Default is Toner save mode. Life is 19K.	Life setting by A4 6% document
3	Developer	MX-235AV	Developer	x1	50K	
4	Drum KIT	AR-205DR	Drum Drum fixing plate	x1 x1	50K	

## 2. Environmental conditions

### A. Transport conditions

#### (1) Transport conditions

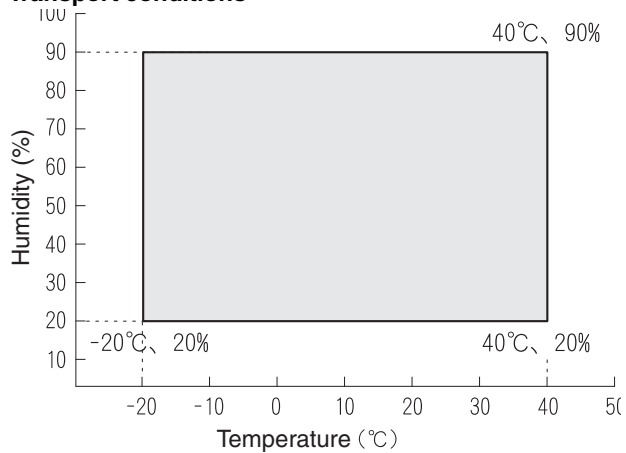

#### (2) Storage conditions

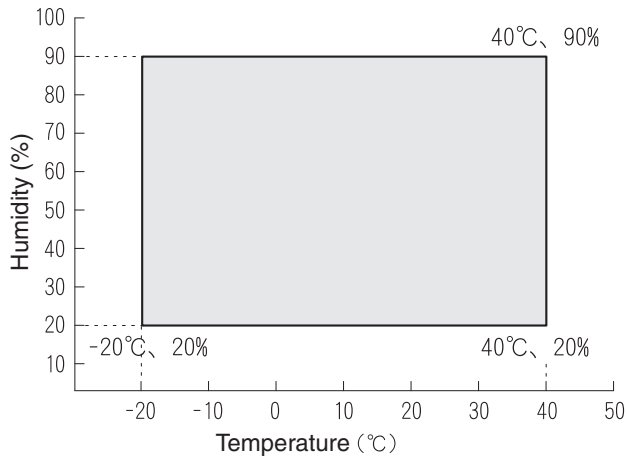

### B. Use conditions

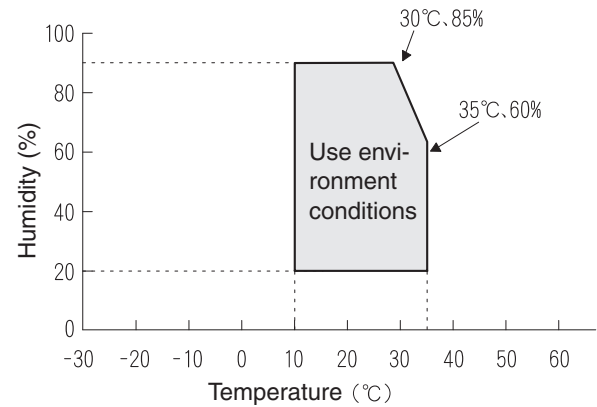

### C. Life(packed conditions)

Photoconductor drum (36 months from the production month)  
Developer, toner (24 months from the production month)

### 3. Production number identification

#### <Toner cartridge>

The label on the toner cartridge shows the date of production.

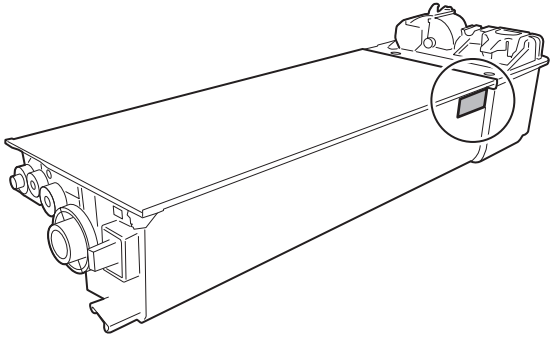
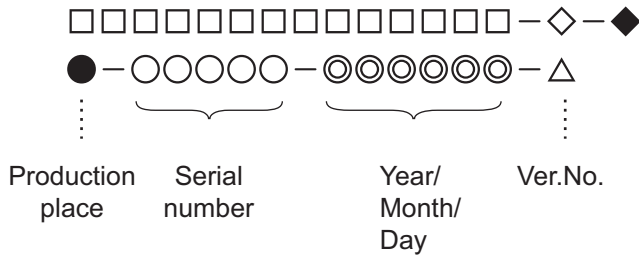

#### <Drum cartridge>

The lot number, printed on the front side flange, is composed of 6 digits, each digit showing the following content:

1	2	3	4	5	6
---	---	---	---	---	---

- 1      Alphabet  
Indicates the model conformity code. A for this model.
- 2      Number  
Indicates the end digit of the production year.
- 3      Number or X, Y, Z  
Indicates the month of packing.  
X stands for October, Y November, and Z December.
- 4/5    Number  
Indicates the day of the month of packing.
- 6      Alphabet  
Indicates the production factory. "A" for Nara Plant, "C" for SOCC

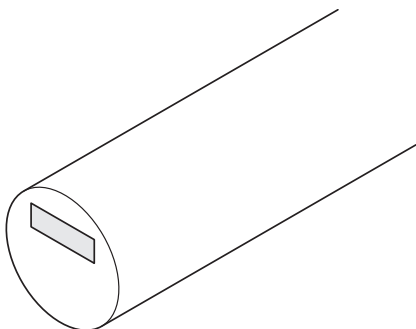

# [5] EXTERNAL VIEWS AND INTERNAL STRUCTURES

## 1. Appearance

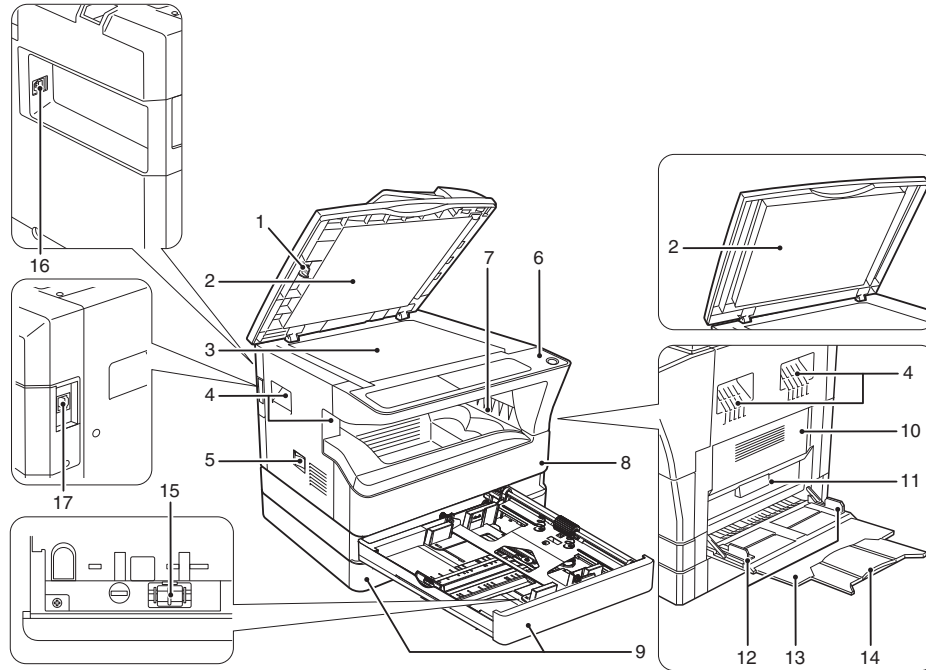

1	Glass cleaner (when the RSPF is installed)	2	Document feeder cover (when the RSPF is installed) /document cover	3	Document glass
4	Handles	5	Power switch	6	Operation panel
7	Paper output tray	8	Front cover	9	Paper trays
10	Side cover	11	Side cover handle	12	Bypass tray guides
13	Bypass tray	14	Bypass tray extension	15	Charger cleaner
16	USB 2.0 connector (AR-5618S/5620S)	17	10Base-T/100Base-TX LAN connector (AR-5618N/5620N/5623N)		

## 2. Internal

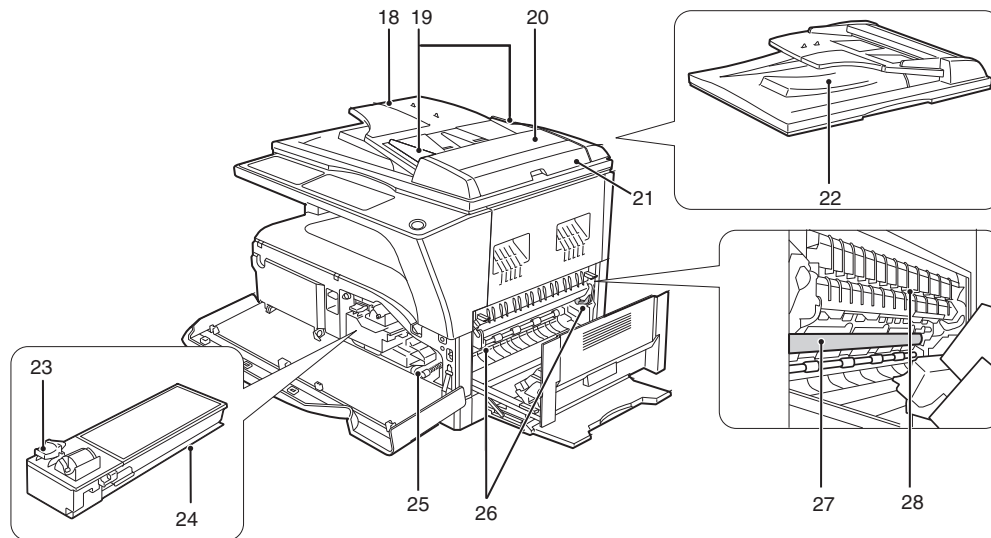

18	Document feeder tray (when the RSPF is installed)	19	Original guides (when the RSPF is installed)	20	Feeding roller cover (when the RSPF is installed)
21	Right side cover (when the RSPF is installed)	22	Exit area (when the RSPF is installed)	23	Toner cartridge lock release lever
24	Toner cartridge	25	Roller rotating knob	26	Fusing unit release levers
27	Photoconductive drum	28	Fusing unit paper guide		

### 3. Operation Section

The indications of the operation panel may differ depending on the country and the region.

This example is of the inch series display.

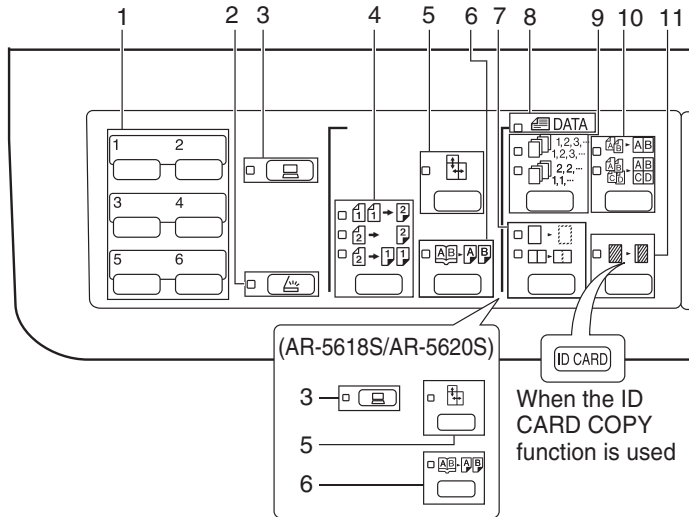
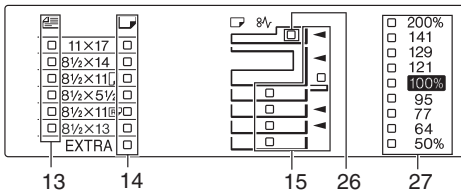

1	SCAN MENU key (AR-5618N/5620N/5623N)	2	SCAN key / indicator (AR-5618N/5620N/5623N)	3	ON LINE key/indicator
4	ORIGINAL TO COPY key/indicators (AR-5618N/5620N/5623N)	5	XY-ZOOM key / indicator	6	DUAL PAGE COPY key / indicator
7	ERASE key / indicators (AR-5618N/5620N/5623N)	8	ORIGINAL DATA indicator (AR-5618N/5620N/5623N)	9	SORT/GROUP key / indicators (AR-5618N/5620N/5623N)
10	2 IN 1 / 4 IN 1 key / indicators (AR-5618N/5620N/5623N)	11	MARGIN SHIFT key / indicator (AR-5618N/5620N/5623N)		

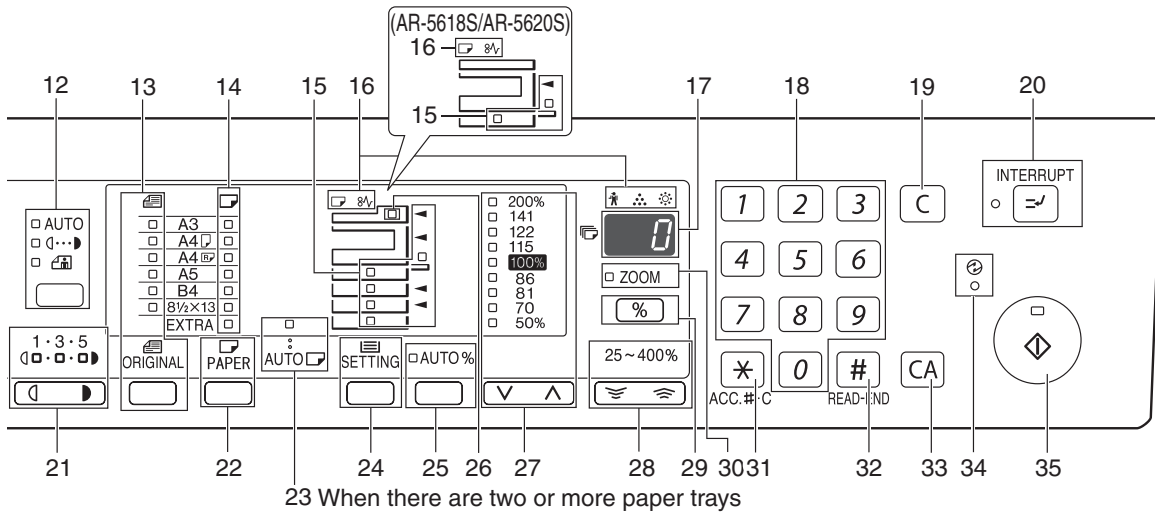

12	AUTO/TEXT/PHOTO key / indicators	13	ORIGINAL key / ORIGINAL SIZE indicators	14	PAPER SIZE indicators
15	Paper feed location / misfeed location indicators	16	Alarm indicators	17	Display
18	Numeric keys	19	CLEAR key	20	INTERRUPT key / indicator
21	Light and Dark keys / indicators	22	PAPER SELECT key	23	AUTO PAPER SELECT indicator (AR-5618N/5620N/5623N)
24	TRAY SETTING key	25	AUTO IMAGE key / indicator	26	RSPF indicator (When the RSPF is installed) (AR-5618N/5620N/5623N)
27	PRESET RATIO selector keys / indicators	28	Zoom keys	29	Copy ratio display key
30	ZOOM indicator	31	Audit clear key	32	READ-END key
33	CLEAR ALL key	34	POWER SAVE indicator	35	START key / indicator

## 4. Motor, solenoid, clutch

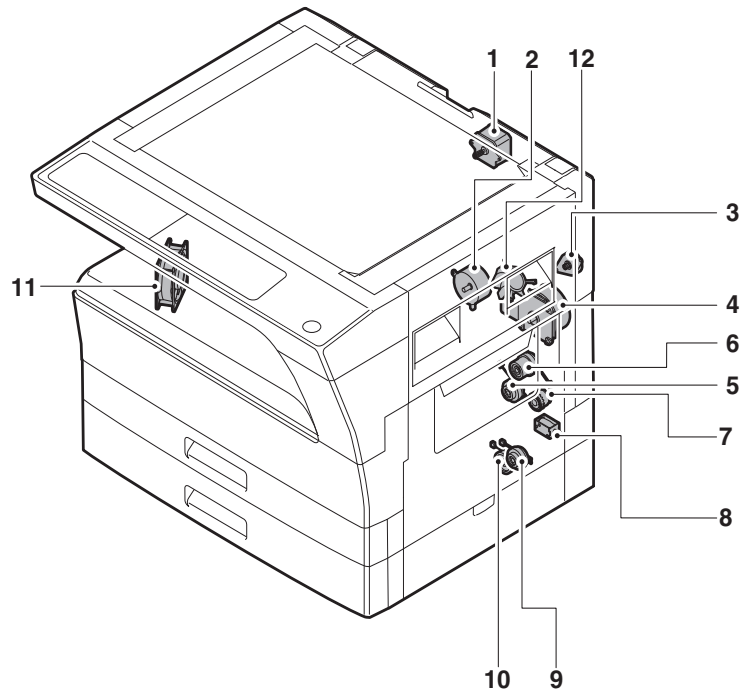

No.	Name	Code	Function operation
1	Mirror motor	MRM	Drives the optical mirror base (scanner unit).
2	Toner motor	TM	Toner supply
3	Duplex motor	DPX	Switchback operation and paper exit motor in duplex.
4	Main motor	MM	Drives the machine.
5	1st tray paper feed clutch	CPSCL1	Drive the pick up roller
6	PS clutch	RRC	Drives the resist roller
7	Bypass tray paper transport clutch	MPTC	Drives the bypass tray paper transport roller.
8	Bypass tray paper feed solenoid	MPFS	Bypass tray paper feed solenoid
9	2nd tray transport clutch	FSCL1	Drives the 2nd tray transport roller. (AR-5620N/5623N only)
10	2nd tray paper feed clutch	PSCL2	Drives the 2nd tray paper feed roller. (AR-5620N/5623N only)
11	Exhaust fan motor	PSFM	Cools the inside of the machine.
12	Cooling fan motor	VFM	Cools the inside of the machine.

## 5. Sensor, switch

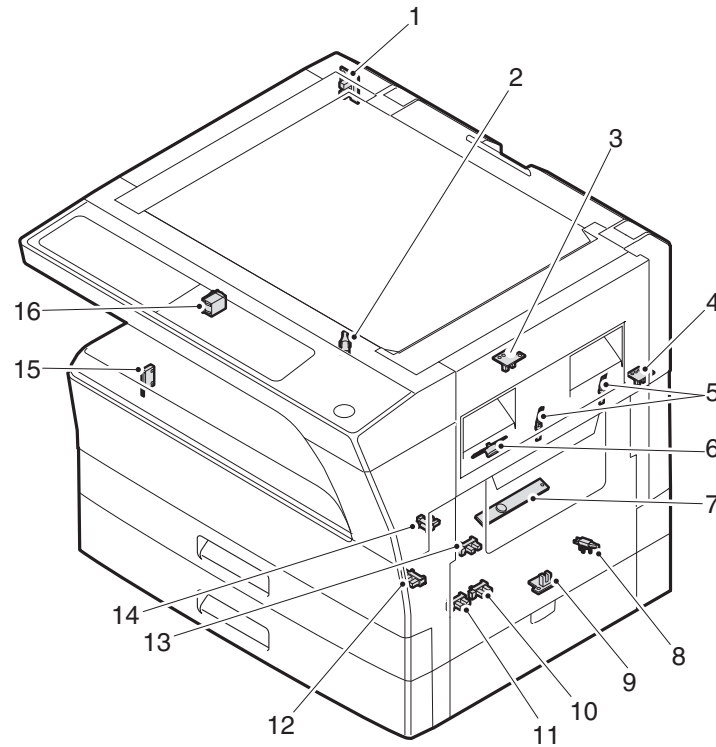

No.	Name	Code	Function operation
1	Mirror home position sensor	MHPS	Detects the mirror (scanner unit) home position.
2	Side door switch	DSWR	Side door open detection
3	Paper exit sensor (paper exit side)	POD1	Detects paper exit.
4	Paper exit sensor (DUP side)	PDPX	Paper transport detection
5	Thermistor	RTH	Fusing section temperature detection
6	Thermostat	RDTCT	Fusing section abnormally high temperature detection
7	Toner density sensor	TCS	Detects the toner density in the developing unit.
8	2nd tray detection switch	CSD2	2nd tray detection
9	Bypass tray sensor	MPED	Bypass tray transport detection
10	2nd tray door open/close sensor	DRS2	2nd tray door open/close detection (AR-5620N/5623N only)
11	2nd tray door paper pass sensor	PPD2	2nd tray paper entry detection (AR-5620N/5623N only)
12	2nd tray paper empty sensor	CSS2	2nd tray paper empty detection (AR-5620N/5623N only)
13	Paper in sensor	PIN	Paper transport detection
14	Tray empty	CSS1	Tray paper entry detection
15	Front cover SW	DSWF	Front cover open detection
16	Power switch	MAIN SW	Turns ON/OFF the main power source.

## 6. PWB unit

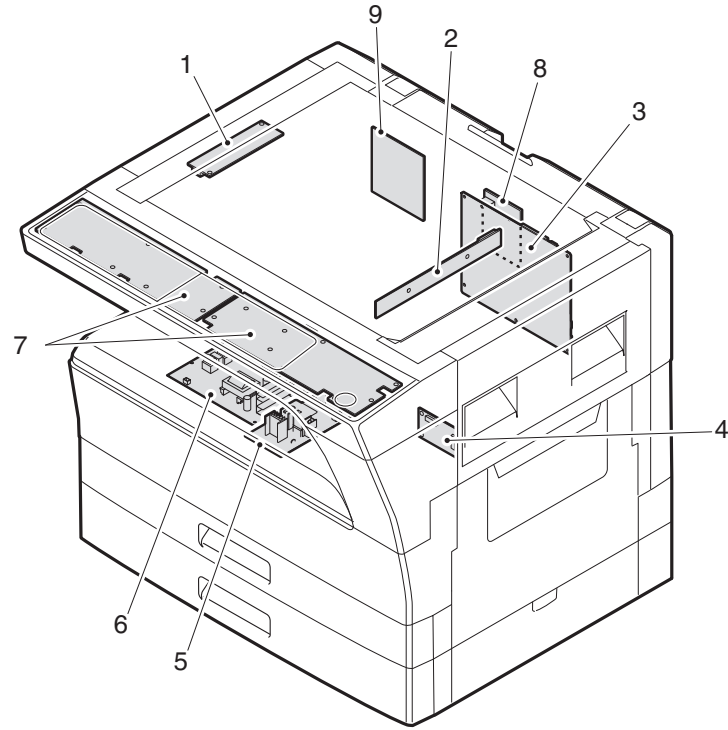

No.	Name	Function operation
1	Copy lamp Inverter PWB	Copy lamp control
2	CCD sensor PWB	Image scanning
3	Main control PWB	Main control PWB
4	2nd tray PWB	2nd tray control
5	High voltage PWB	High voltage control
6	Power PWB	AC power input/DC power control
7	Operation main PWB	Operation panel input/Display, operation panel section control
8	USB I/F PWB	Connect a USB device (AR-5618S/5620S only)
9	Nic PWB	Network interface PWB (AR-5618N/5620N/5623N only)

## 7. Cross sectional view

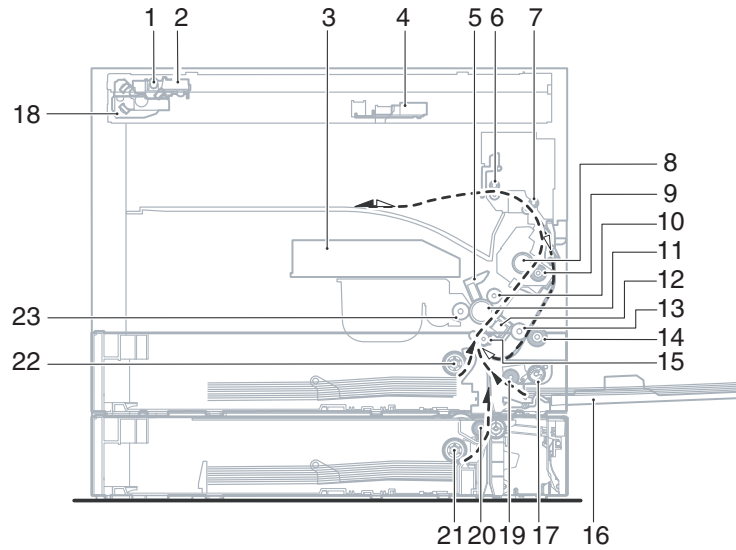

No.	Name	Function/Operation
1	Copy lamp	Image radiation lamp
2	Copy lamp unit	Operates in synchronization with No. 2/3 mirror unit to radiate documents sequentially.
3	LSU unit	Converts image signals into laser beams to write on the drum.
4	Lens unit	Reads images with the lens and the CCD.
5	MC holder unit	Supplies negative charges evenly on the drum.
6	Paper exit roller	Used to discharge paper.
7	Transport roller	Used to transport paper.
8	Upper heat roller	Fuses toner on paper (with the teflon roller).
9	Lower heat roller	Fuses toner on paper (with the silicon rubber roller).
10	Waste toner transport roller	Transports waste toner to the waste toner box.
11	Drum unit	Forms images.
12	Transfer charger unit	Transfer images (on the drum) onto paper.
13	DUP follower roller	Transports paper for duplex.
14	Duplex transport roller	Transports paper for duplex .
15	Resist roller	Takes synchronization between the paper lead edge and the image lead edge.
16	Bypass tray	Bypass tray
17	Bypass tray paper pick up roller	Picks up paper in bypass tray.
18	No. 2/3 mirror unit	Reflects the images from the copy lamp unit to the lens unit.
19	Bypass tray transport roller	Transports paper from the bypass tray.
20	2nd tray paper transport roller	Transports paper from the 2nd tray. (AR-5620N/5623N only)
21	2nd tray paper pick up roller (semi-circular roller)	Picks up paper from the 2nd tray. (AR-5620N/5623N only)
22	1st tray paper feed roller (semi-circular roller)	Picks up paper from the 1st tray.
23	MG roller	Puts toner on the OPC drum.

# [6] ADJUSTMENTS

## 1. Adjustment item list

Section		Adjustment item		Adjustment procedure/SIM No.
A	Process section	(1)	Developing doctor gap adjustment	Developing doctor gap adjustment
		(2)	MG roller main pole position adjustment	MG roller main pole position adjustment
		(3)	Developing bias voltage check	
		(4)	Main charger voltage check	
B	Mechanism section	(1)	Image position adjustment	SIM-50
		(2)	Main scanning direction (FR direction) distortion balance adjustment	No. 2/3 mirror base unit installing position adjustment Copy lamp unit installing position adjustment
		(3)	Main scanning direction (FR direction) distortion adjustment	Rail height adjustment
		(4)	Sub scanning direction (scanning direction) distortion adjustment	Winding pulley position adjustment
		(5)	Main scanning direction (FR direction) magnification ratio adjustment	SIM 48-1
		(6)	Sub scanning direction (scanning direction) magnification ratio adjustment	OC mode in copying (SIM 48-1) SPF mode in copying (SIM 48-5)
		(7)	Off center adjustment	OC mode (SIM 50-12) SPF mode (SIM 50-12)
		(8)	SPF white correction pixel position adjustment (required in an SPF model when replacing the lens unit)	SIM63-7
C	Image density adjustment	(1)	Copy mode	SIM 46-2

## 2. Copier adjustment

### A. Process section

#### (1) Developing doctor gap adjustment

- Loosen the developing doctor fixing screw A.
- Insert a thickness gauge of 1.5mm to the three positions at 20mm and 150mm from the both ends of the developing doctor as shown.

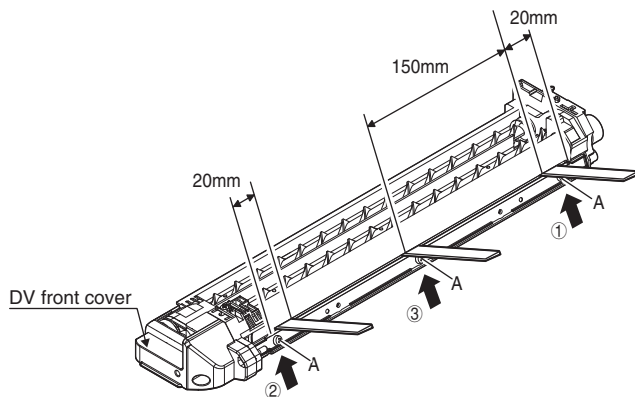

- Push the developing doctor in the arrow direction, and tighten the fixing screws of the developing doctor in the sequence of ①→②→③.
- Check the clearance of the developing doctor. If it is within the specified range, then fix the doctor fixing screw with screw lock.

\* When inserting a thickness gauge, be careful not to scratch the developing doctor and the MG roller.

#### <Adjustment specification>

Developing doctor gap

Both ends (20mm from the both ends) :  $1.5 \pm 0.1\text{mm}$

C (Center) (150mm from the both ends) :  $1.5 \pm 0.1\text{mm}$

#### (2) MG roller main pole position adjustment

- Remove the DV front cover, and put the developing tank on a flat surface.
- Tie a string to a needle or a pin.
- Hold the string and bring the needle close to the MG roller horizontally. (Do not use paper clip, which is too heavy to make a correct adjustment.) (Put the developing unit horizontally for this adjustment.)
- Do not bring the needle into contact with the MG roller, but bring it to a position 2 or 3mm apart from the MG roller. Mark the point on the MG roller which is on the extension line from the needle tip.
- Measure the distance from the marking position to the top of the doctor plate of the developing unit to insure that it is 18mm. If the distance is not within the specified range, loosen the fixing screw A of the main pole adjustment plate, and move the adjustment plate in the arrow direction to adjust.

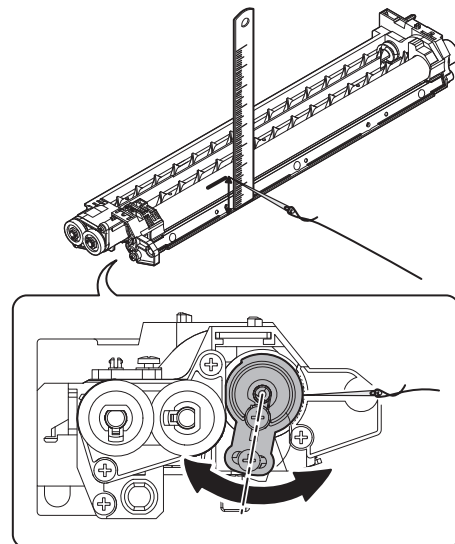

### (3)Developing bias voltage check

Note:Use a digital multi-meter with an internal resistance of 10MΩ or more.

- 1) Set the digital multi-meter range above 500 Vdc.
- 2) Put the test rod of the digital multi-meter on the developing bias voltage output check pin.
- 3) Turn on the power, execute SIM25-1.

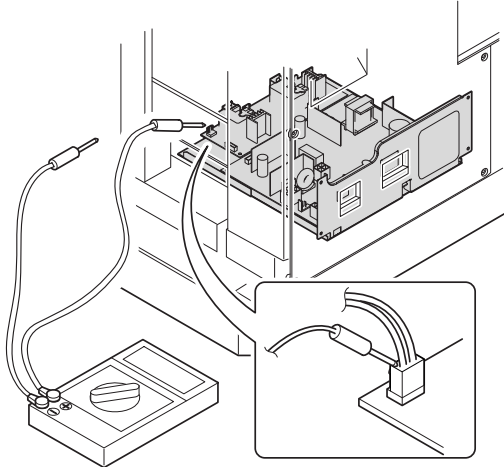

#### <Specification>

Mode	Specification
Developing bias voltage	DC - 400±10V

### (4) Grid bias voltage check

Note:Use a digital multi-meter with an internal resistance of 10MΩ or more.

- 1) Set the digital multi-meter range above 600 Vdc.
- 2) Put the test rod of the digital multi-meter on the grid bias voltage output check pin.
- 3) Turn on the power.  
(The voltage is outputted in the grid bias High output mode during warming up, and in the grid bias Low output mode when warming up is completed.)

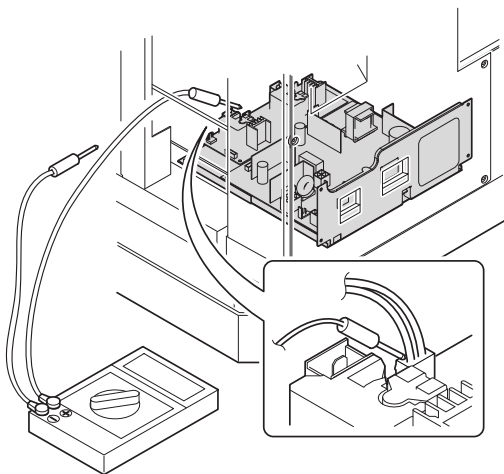

#### <Specification>

Mode	Specification
Grid bias LOW	DC - 380±8V
Grid bias HIGH	DC - 525±10V

## B.Mechanism section

Note: If a jam error or paper empty occurs during copying in the adjustment by the simulation, the image data is not saved, and therefore recopying is required.

### (1) Image position adjustment

#### a.OC image lead edge position adjustment (SIM 50-1)

Note:In advance to this adjustment, the sub scanning magnification ratio adjustment must be performed.

- 1) Set a scale on the OC table as shown below.

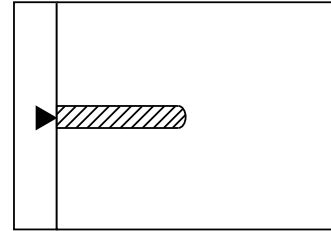

- 2) Make a copy.
- 3) Check the copy output. If necessary, perform the following adjustment procedures.
- 4) Execute SIM 50-1.
- 5) Set the OC lead edge position set value (PHOTO indicator ON) to [1]. The OC image scanning start position is shifted inside the document edge.
- 6) Set the 1st tray lead edge void adjustment value (TEXT indicator ON) \* to [1]. The lead edge void becomes the minimum.
- 7) Set the 1st tray print start position value (AUTO, 1st tray indicator ON) to [1] and make a copy. The print start position is shifted inside the document edge.

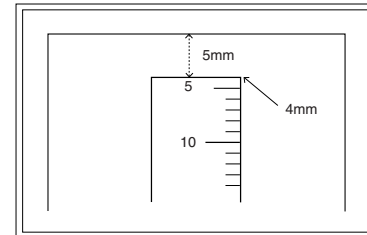

\* The dimension varies depending on the model.

- 8) Measure the image loss R of the copied image. Enter the set value of the image scanning lead edge position (PHOTO indicator ON) again.

•1 step of the set value corresponds to about 0.1mm shift.

•Calculate the set value from the formula below.

$$R/0.1(\text{mm}) = \text{Image loss set value}$$

<R: Image loss measurement value (mm)>

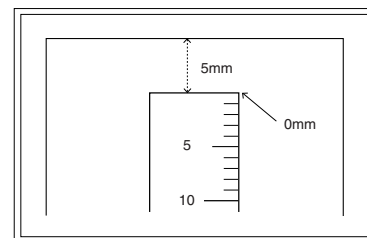

\* The scanning edge is set.  
(A line may be printed by scanning the document edge.)

Example:  $4/0.1 = 40 = \text{about } 40$

Note:If the set value is not obtained from the above formula, perform the fine adjustment.

9) Measure the distance H between the paper lead edge and the image print start position. Set the image print start position set value (AUTO, 1st tray indicator ON) again.

- 1 step of the set value corresponds to about 0.1mm shift.
- Calculate the set value from the formula below.  
 $H/0.1(\text{mm}) = \text{Image print start position set value}$   
 <H: Print start position measurement value (mm)>

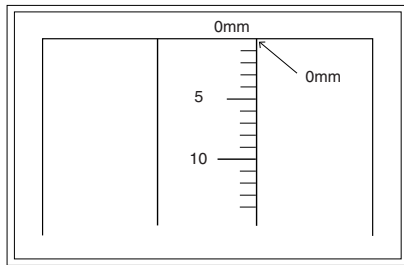

\*Fit the print edge with the paper edge, and perform the lead edge adjustment.

Example:  $5/0.1 = 50 = \text{about } 50$

Note: If the set value is not obtained from the above formula, perform the fine adjustment.

10) Set the lead edge void adjustment value (TEXT indicator ON)\* again.

- 1 step of the set value corresponds to about 0.1mm shift.
- Calculate the set value from the formula below.  
 $B/0.05(\text{mm}) = \text{Lead edge void adjustment value}$   
 <B: Lead edge void (mm)>

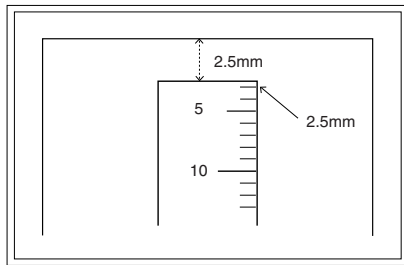

Example: When setting the lead edge void to 2.5mm  
 $2.5/0.05 = \text{about } 50$

Note: If the set value is not obtained from the above formula, perform the fine adjustment.

- \* 2nd tray lead edge void adjustment: Exposure display <<AUTO + TEXT + PHOTO>>
- Bypass tray lead edge void adjustment: (TEXT indicator and PHOTO indicator ON)

<Duplex mode adjustment>

OC 2nd print surface (Auto duplex) lead edge position adjustment: SIM50-19 <<PHOTO>>

\* For the adjustment procedure, set to S → D mode before execution.

Note: Before performing the 2nd print surface lead edge position adjustment and the lead edge void adjustment, be sure to perform the 1st print surface lead edge position adjustment in advance, and be sure to perform the 2nd print surface lead edge position adjustment and then the lead edge void adjustment in this sequence.

<Adjustment specification>

Adjustment mode	SIM	LED	Set value	Spec value	Set range
OC image lead edge position	SIM 50-1	PHOTO	R/0.1	Lead edge void: 1 - 4mm  Image loss: 3mm or less	1 ~ 99
1st tray print start position		AUTO + 1st tray	B/0.1		
2nd tray print start position		AUTO + 2nd tray			
Bypass tray print start position		AUTO + Bypass tray			
Lead edge void		TEXT	B/0.05		
OC 2nd print surface lead edge position adjustment	SIM 50-19*	PHOTO	1 step: 0.1mm shift		

\* (Set to S → D mode for before execution)

b.SPF image lead edge position adjustment (SIM50-6)

1) Set a scale on the OC table as shown below.

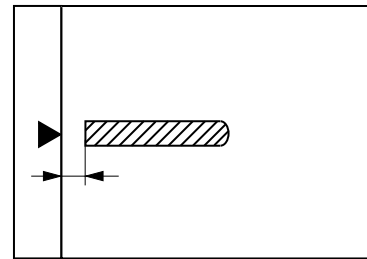

Note: Since the printed copy is used as a test chart, put the scale in parallel with the edge lines.

- 2) Make a copy, Then use the copy output as an original to make an SPF copy again.
- 3) Check the copy output. If necessary, perform the following adjustment procedures.
- 4) Execute SIM 50-6.
- 5) Set the SPF lead edge position set value (AUTO indicator ON) so that the same image is obtained as that obtained in the previous OC image lead edge position adjustment.

<Adjustment specification>

Adjustment mode	SIM	LED	Set value	Spec value	Set range
SPF image lead edge position (1st print surface)	SIM 50-6	AUTO	1 step: 0.1mm shift	Lead edge void: 1 - 4mm	1 ~ 99
(2nd print surface)		TEXT			

### c. Rear edge void adjustment (SIM50-1, SIM50-19)

- 1) Set a scale as shown in the figure below.

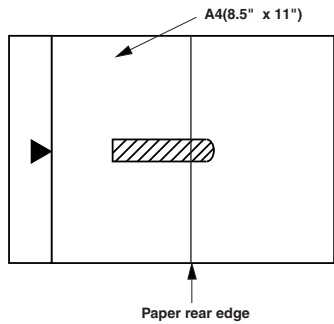

- 2) Set the document size to A4 (8.5" x 11"), and make a copy at 100%.
- 3) If necessary, perform the following adjustment procedure.

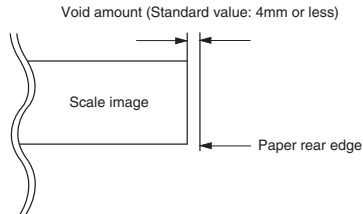

- 4) Execute SIM 50-1 and set the density mode to AUTO + TEXT + PHOTO (Rear edge void). The currently set adjustment value is displayed.
- 5) Enter the set value and press the [START] key. The correction value is stored and a copy is made.

#### <Duplex mode adjustment>

- \* 1st print surface (auto duplex) rear edge void adjustment: SIM50-19 <<AUTO>>
- \* 2nd print surface (auto duplex) rear edge void adjustment: SIM50-19 <<TEXT>>
- \* Set to S → D mode before execution.

Note: Before performing the 2nd print surface rear edge void adjustment, be sure to perform the 2nd print surface lead edge position adjustment. Never reverse the sequence.

#### <Adjustment specification>

Mode	SIM	LED	Set value	Specifi- cation	Set range
Rear edge void	SIM 50-1	AUTO + TEXT + PHOTO	1 step: 0.1mm shift	4mm or less	1 ~ 99
1st print surface rear edge void	SIM 50-19*	AUTO			
2nd print surface rear edge void	SIM 50-19*	TEXT			

- \* Set to S → D mode before execution

### d. Paper off center adjustment (SIM50-10)

- 1) Set a test chart (UKOG-0089CSZZ) on the document table.
- 2) Select a paper feed port and make a copy. Compare the copy and the test chart. If necessary, perform the following adjustment procedure.
- 3) Execute SIM 50-10. After completion of warm-up, shading is performed and the currently set off center adjustment value of each paper feed port is displayed.
- 4) Enter the set value and press the [START] key. The correction value is stored and a copy is made.

### <Duplex mode adjustment>

- \* 2nd print surface (auto duplex) off-center adjustment: SIM50-10 (TEXT, 1st tray indicator)

#### <Adjustment specification>

Mode	SIM	LED	Set value	Specifi- cation	Set range
Paper off center	SIM 50-10	AUTO + Selected tray ON	Add 1: 0.1mm shift to R side.	Single: Center ±2.0mm	1 ~ 99
2nd print surface off-center	SIM 50-10	TEXT + 1st tray	Reduce 1: 0.1mm shift to L side.	Duplex: Center ±2.5mm	

### e. Side edge void area adjustment (SIM26-43)

Note: Before performing this adjustment, be sure to check that the paper off center adjustment (SIM 50-10) is completed.

- 1) Set a test chart (UKOG-0089CSZZ) on the document table.
- 2) Select a paper feed port and make two copies. Compare the 2nd copy and the test chart. If necessary, perform the following adjustment procedure.
  - \* The 1st copy does not show the void. Be sure to check the 2nd copy.
- 3) Execute SIM 26-43 and set the density mode to AUTO(right edge void) + TEXT (Left edge void). The currently set adjustment value is displayed.
- 4) Enter the set value and press the [START] key. The correction value is stored.

#### <Adjustment specification>

ode	SIM	LED	Set value	Specifi- cation	Set range
Left edge void	SIM 26-43	AUTO (right edge) + TEXT (left edge)	1 step: 0.5mm shift	0 ~ 10mm	0 ~ 10

- \* The void adjustment values on the right and the left must be the same.

### (2) Main scanning direction(FR direction) distortion balance adjustment

- 1) Remove the OC glass and the right cabinet.

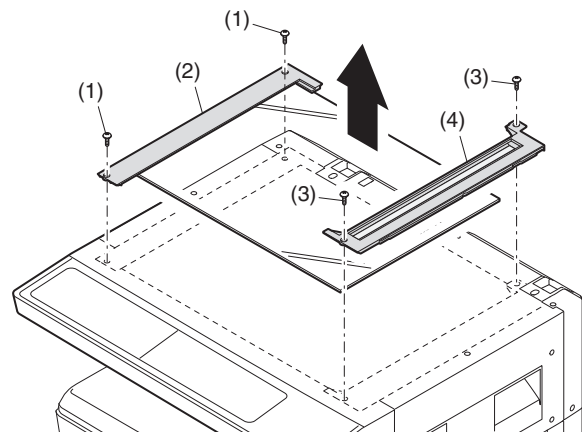

- 2) Loosen the copy lamp unit wire fixing screw.

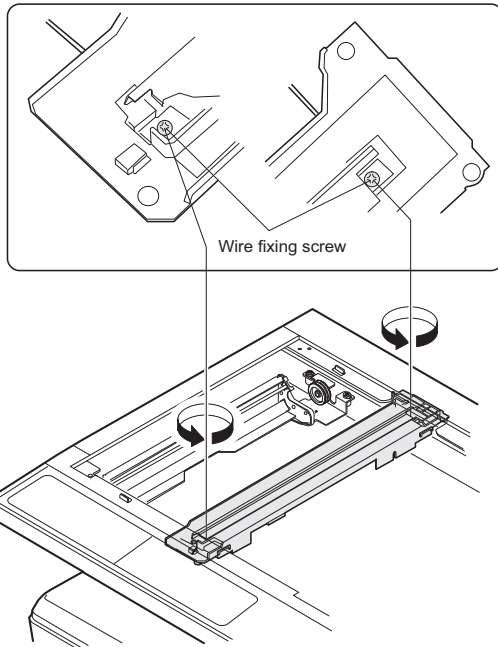

- 3) Manually turn the mirror base drive pulley and bring No. 2/3 mirror base unit into contact with the positioning plate. At that time, if the front frame side and the rear frame side of No. 2/3 mirror base unit are brought into contact with the positioning plate at the same time, the mirror base unit parallelism is proper. If one of them is in contact with the positioning plate, perform the adjustment of 4).

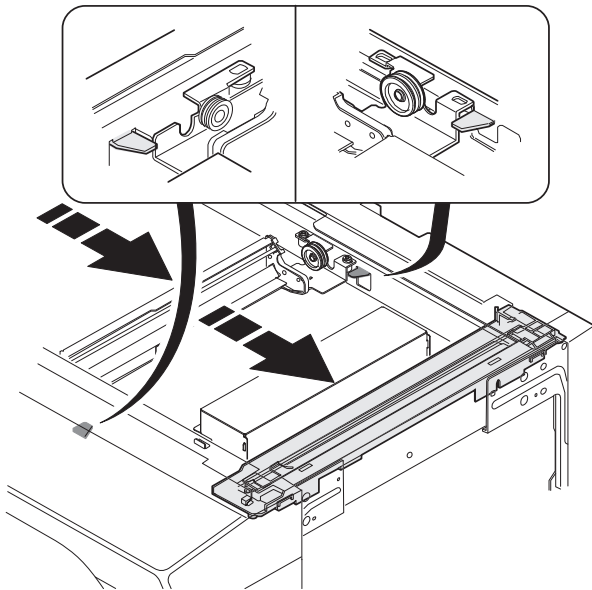

- 4) Loosen the set screw of the scanner drive pulley which is not in contact with No. 2/3 mirror base unit positioning plate.  
5) Without moving the scanner drive pulley shaft, manually turn the scanner drive pulley until the positioning plate is brought into contact with No. 2/3 mirror base unit, then fix the scanner drive pulley.

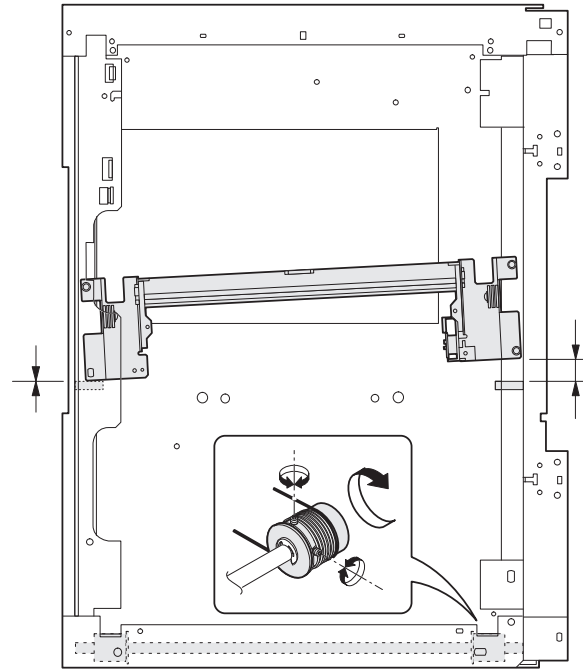

- 6) Put No. 2/3 mirror base unit on the positioning plate again, push the projections on the front frame side and the rear frame side of the copy lamp unit to the corner frame, and tighten the wire fixing screw.

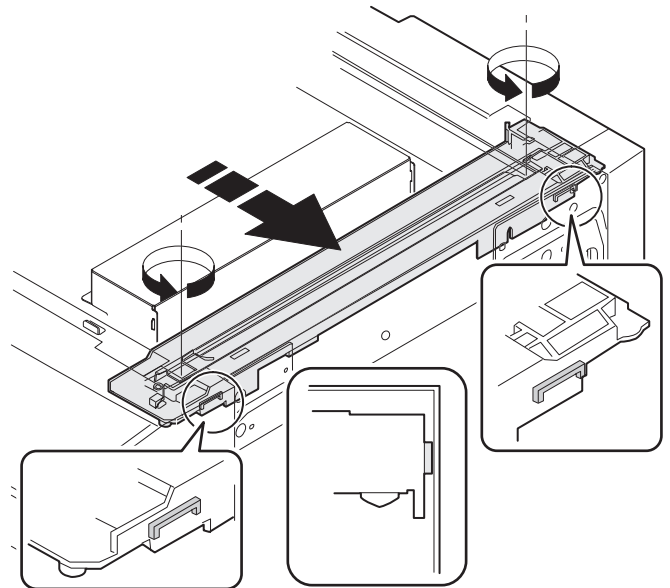

### (3) Main scanning direction (FR direction) distortion adjustment

This adjustment must be performed in the following cases:

- When the mirror base drive wire is replaced.
- When the lamp unit, or No. 2/3 mirror holder is replaced.
- When a copy as shown is made.

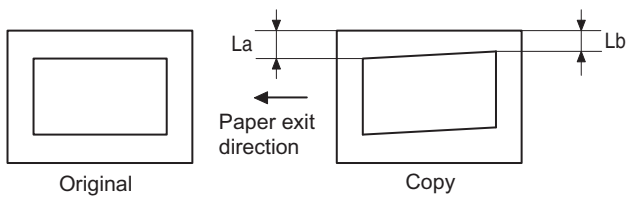

- 1) Set A3 (11" x 17") white paper on the original table as shown below.

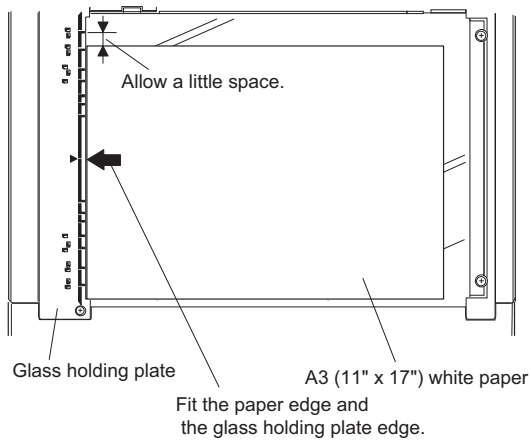

- 2) Open the original cover and make a normal (100%) copy.
- 3) Measure the width of the black background at the lead edge and at the rear edge.

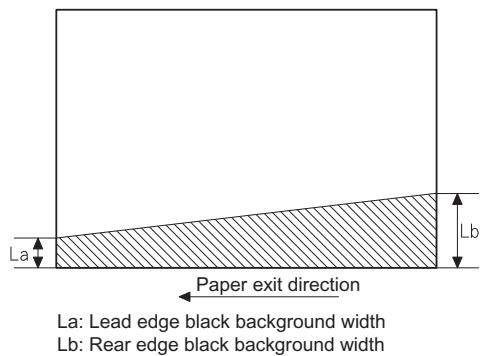

If the width (La) of the black background at the lead edge is equal that (Lb) at the rear edge, there is no need to execute the following procedures of 4) ~ 7).

- 4) Loosen the mirror base drive pulley fixing screw on the front frame side or on the rear frame side.

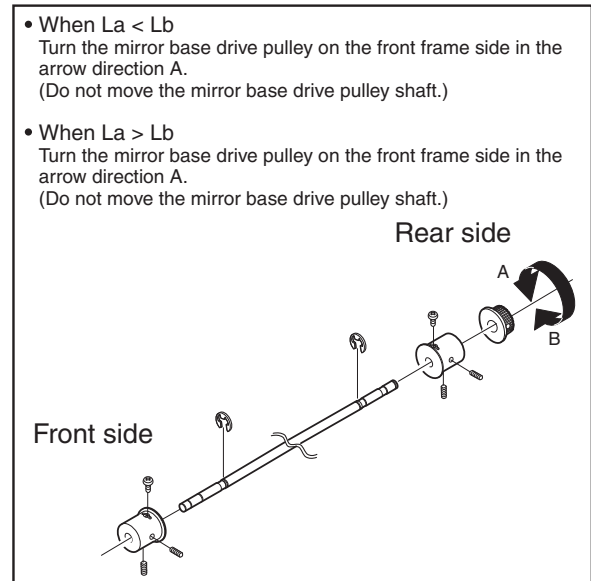

- 5) Tighten the mirror base drive pulley fixing screw.

#### <Adjustment specification>

$L_a = L_b$

- 6) Execute the main scanning direction (FR) distortion balance adjustment previously described in 2) again.

### (4) Sub scanning direction (scanning direction) distortion adjustment

When there is no skew copy in the mirror base scanning direction and there is no horizontal error (right angle to the scanning direction), the adjustment can be made by adjusting the No. 2/3 mirror base unit rail height.

Before performing this adjustment, be sure to perform the horizontal image distortion adjustment in the laser scanner section.

This adjustment must be performed in the following cases:

- When the mirror base wire is replaced.
- When the copy lamp unit or No. 2/3 mirror unit is replaced.
- When the mirror unit rail is replaced or moved.
- When a following copy is made.

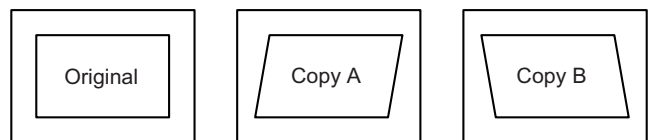

1) Making of a test sheet

Make test sheet by drawing parallel lines at 10mm from the both ends of A3 (11" x 17") white paper as shown below. (These lines must be correctly parallel to each other.)

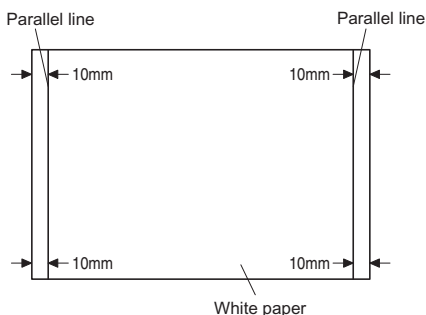

- 2) Make a normal (100%) copy of the test sheet on A3 (11" x 17") paper. (Fit the paper edge with the glass holding plate edge.)
- 3) Measure the distances (La, Lb, Lc, Ld) at the four corners as shown below.

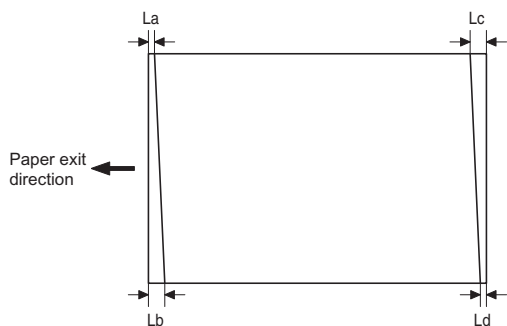

When  $L_a = L_b$  and  $L_c = L_d$ , no need to perform the procedures 4) and 5).

- 4) Move the mirror base F rail position up and down (in the arrow direction) to adjust.

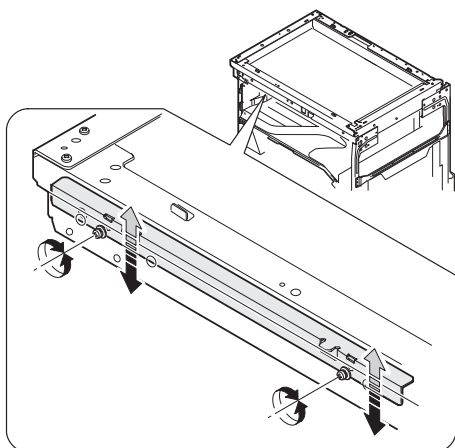

Note: Do not adjust the rail on the rear side.  
If the rail on the rear side is adjusted, an error may occur.  
Only the rail on the front side can be adjusted.

- When  $L_a > L_b$   
Shift the mirror base B rail upward by the half of the difference of  $L_a - L_b$ .
  - When  $L_a < L_b$   
Shift the mirror base B rail downward by the half of the difference of  $L_b - L_a$ .  
Example: When  $L_a = 12\text{mm}$  and  $L_b = 9\text{mm}$ , shift the mirror base B rail upward by 1.5mm.
  - When  $L_c > L_d$   
Shift the mirror base B rail downward by the half of the difference of  $L_c - L_d$ .
  - When  $L_c < L_d$   
Shift the mirror base B rail downward by the half of the difference of  $L_d - L_c$ .
- \* When moving the mirror base rail, hold the mirror base rail with your hand.

<Adjustment specification>

$L_a = L_b, L_c = L_d$

- 5) After completion of adjustment, manually turn the mirror base drive pulley, scan the mirror base A and mirror base B fully, and check that the mirror bases are not in contact with each other.
- \* If the mirror base rail is adjusted to extreme, the mirror base may contact the frame or original glass. Be careful to avoid this.

**(5) Main scanning direction (FR direction) magnification ratio adjustment (SIM 48-1)**

Note: Before performing this adjustment, be sure the CCD unit is within specification.

- 1) Put a scale on the original table as shown below.

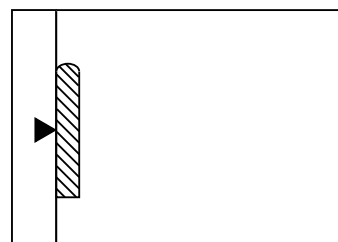

- 2) Execute SIM 48-1.
- 3) After warm-up, shading is performed and the current set value of the main scanning direction magnification ratio is displayed on the display section in 2 digits.
- 4) Select the mode and press the [START] key again.
- 5) Manual correction mode (TEXT indicator ON)  
Enter the set value and press the [START] key.  
The set value is stored and a copy is made.

**<Adjustment specification>**

Note: A judgment must be made with 200mm width, and must not be made with 100mm width.

Mode	Specification	SIM	Set value	Set range
Main scanning direction magnification ratio	At normal: $\pm 1.0\%$	SIM 48-1	Add 1:0.1% increase Reduce 1: 0.1% decrease	1 ~ 99

**(6) Sub scanning direction (scanning direction) magnification ratio adjustment (SIM 48-1, SIM 48-5)**

**a. OC mode in copying (SIM48-1)**

Note: Before performing this adjustment, be sure the CCD unit is within specification.

- Put a scale on the original table as shown below, and make a normal (100%) copy.
- Compare the scale image and the actual image. If necessary, perform the following adjustment procedures.
- Execute SIM 48-1.<<PHOTO>>
- After warm-up, shading is performed and the current set value of the main scanning direction magnification ratio is displayed on the display section in 2 digits.
- When the photo indicator is lighted by pressing the AUTO/TEXT/PHOTO key, the current magnification ratio correction value in the sub scanning direction is displayed in lower 2 digits of the display section.
- Enter the set value and press the [START] key.  
The set value is stored and a copy is made.

**<Adjustment specification>**

Mode	Specification	SIM	Set value	Set range
Sub scanning direction magnification ratio (OC mode)	Normal $\pm 1.0\%$	SIM 48-1 (PHOTO)	Add 1:0.1% increase Reduce 1: 0.1% decrease	1 ~ 99

**b. RSPF sub scanning direction magnification ratio (SIM48-5)**

Note:

- Before performing this adjustment, be sure the CCD unit is within specification.
- Before performing this adjustment, the OC mode adjustment in copying must be completed.

- Put a scale on the original table as shown below, and make a normal (100%) copy to make a test chart.

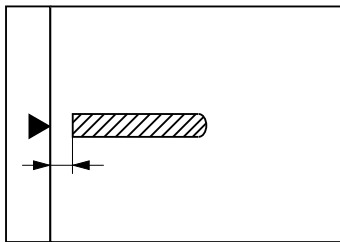

Note: Since the printed copy is used as a test chart, put the scale in parallel with the edge lines.

- Set the test chart on the SPF and make a normal (100%) copy.
- Compare the scale image and the actual image. If necessary, perform the following adjustment procedures.
- Execute SIM 48-5.
- After warm-up, shading is performed.  
The AUTO indicator lights up and the current front surface sub scanning direction magnification ratio correction value is displayed in two digits on the display section.

- Enter the set value and press the [START] key.  
The set value is stored and a copy is made.
- Change the mode from the duplex original mode to the simplex original mode.  
TEXT indicator lights up and the current back surface sub scanning direction magnification ratio is displayed in two digits on the display section.
- Enter the set value and press the [START] key.  
The set value is stored and a copy is made.

**<Adjustment specification>**

Mode	Specification	SIM	Set value	Set range
Sub scanning direction magnification ratio (SPF mode)	Normal $\pm 1.0\%$	SIM 48-5	Add 1:0.1% increase Reduce 1: 0.1% decrease	1 ~ 99

**(7) Off center adjustment (SIM 50-12)**

**a. OC mode (SIM50-12)**

- Make a test chart as shown below and set it so that its center line is fit with the original guide center mark.
- \* To make a test chart, draw a line on A3 or 11" x 17" paper at the center in the paper transport direction.

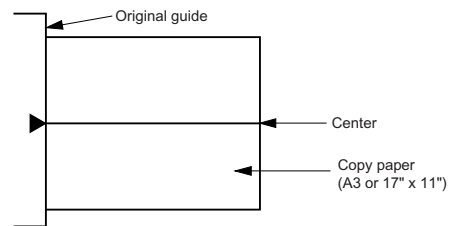

- Make a normal copy from the bypass tray, and compare the copy and the test chart.  
If necessary, perform the following adjustment procedures.
- Execute SIM 50-12.
- After warm-up, shading is performed and the current set value of the off center adjustment is displayed on the display section in 2 digits.
- Enter the set value and press the [START] key.  
The set value is stored and a copy is made.

**<Adjustment specification>**

Mode	Specification	SIM	Set value	Set range
Original off center mode (OC mode)	Single: Center $\pm 2.0\text{mm}$	SIM 50-12 (AUTO indicator ON)	Add 1: 0.1mm shift to R side Reduce 1: 0.1mm shift to L side	1 ~ 99

## b. SPF original off-center adjustment (SIM50-12)

Note: Before performing this adjustment, be sure to check that the paper off center is properly adjusted.

- 1) Make a test chart for the center position adjustment and set it on the SPF.

### <Adjustment specification>

Draw a line on a paper in the scanning direction.

- 2) Make a normal copy from the bypass tray, and compare the copy and the original test chart.

If necessary, perform the following adjustment procedures.

- 3) Execute SIM 50-12.
- 4) After warm-up, shading is performed and the current set value of the off center adjustment at each paper feed port is displayed on the display section in 2 digits.
- 5) Enter the set value and press the [START] key.  
The set value is stored and a copy is made.

### <Adjustment specification>

Mode	Specification	SIM	Set value	Set range
Original off center mode (SPF mode)	Single: Center $\pm 3.0\text{mm}$ (TEXT indicator)	SIM 50-12	Add 1: 0.1mm shift to R side	1 ~ 99
	Duplex: Center $\pm 3.5\text{mm}$ (PHOTO indicator)		Reduce 1: 0.1mm shift to L side	

## (8) SPF white correction pixel position adjustment (SIM63-7) (required in an SPF model when replacing the lens unit)

- 1) Fully open the SPF.
- 2) Execute SIM 63-7.  
If the value is 93 - 229, it is displayed on the display and written into the EEPROM.  
If the value is 0 - 92 or 230 - 999, it is displayed on the display but not written into the EEPROM.  
If the value is 1000 or above, "--" is displayed on the display and it is not written into the EEPROM.

•When the display is 0:

Check that the SPF is open.

Check that the lamp is ON. (If the lamp is OFF, check the MCU connector.)

Check that the CCD harness is properly inserted into the MCU connector.

•When the display is 281 or above:

- 1) Remove the table glass.
- 2) Remove the dark box.
- 3) Slide the lens unit toward the front side and attach it, then execute SIM.

•When the display is 143 or below:

- 1) Remove the table glass.
- 2) Remove the dark box.
- 3) Slide the lens unit toward the rear side and attach it, then execute SIM.

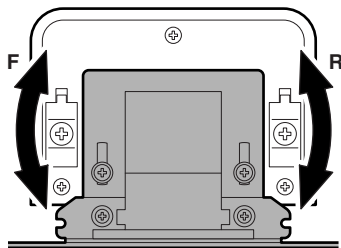

\* When the lens unit is moved, execute the OC main scanning magnification ratio auto adjustment, SIM 48-1-1, SIM 48-3 and the PF original off-center adjustment.

\* This adjustment is basically O.K. with SIM 63-7.

## C. Image density adjustment

### (1) Copy mode (SIM 46-2)

- 1) Set a test chart (UKOG-0162FCZZ) on the OC table as shown below.

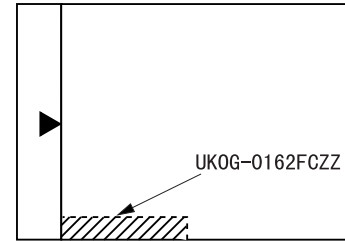

- 2) Put several sheets of A3 or 11" x 17" white paper on the test chart.
- 3) Execute SIM 46-2.
- 4) After warm-up, shading is performed and the current set value of the density level is displayed on the display section in 2 digits.  
For mode selection, use the AUTO/TEXT/PHOTO key.
- 5) Change the set value with the Numeric keys to adjust the copy image density.
- 6) Make a copy and check that the specification below is satisfied.

### <Adjustment specification>

Density mode	LED	Exposure level	Sharp Gray Chart output	Set value	Set range
Auto	Auto	-	"2" is slightly copied.	The greater the set value is the greater the density is. The smaller the set value is the smaller the density is.	1 ~ 99
Text	Text	3	"3" is slightly copied.		
Photo (Error diffusion)	Photo	3	"2" is slightly copied.		
Toner save	Auto/Photo	-	"2" is slightly copied.		
Toner save	Text/Photo	3	"3" is slightly copied.		
Photo (Dither)	Auto/Text/Photo	3	"2" is slightly copied.		

## [7] SIMULATIONS

### 1. Entering the simulation mode

Perform the following procedure to enter the simulation mode.

"#" key → Interrupt key → CLEAR key (C) → Interrupt key →

Main code → [START] key → Sub code → [START] key

### 2. Canceling the simulation mode

When the CLEAR ALL key is pressed, the simulation mode is cancelled.

When the INTERRUPT key is pressed, the process is interrupted and the screen returns to the sub code entering display.

\* After canceling the simulation mode, be sure to turn OFF/ON the power and check the operation.

Note: If the machine is stopped by a misfeed or paper empty while in the simulation mode or adjustment, the simulation / adjustment must be restarted.

### 3. List of simulations

Main code	Sub code	Contents
01	01	Mirror scanning operation
	02	Mirror home position sensor (MHPS) status display
	06	Mirror scanning operation aging
02	01	Single paper feeder (SPF) aging
	02	SPF sensor status display
	03	SPF motor operation check
	08	SPF paper feed solenoid operation check
	09	RSPF reverse solenoid operation check
	11	SPF PS release solenoid operation check
05	01	Operation panel display check
	02	Fusing lamp and cooling fan operation check
	03	Copy lamp lighting check
06	01	Paper feed solenoid/clutch operation check
	02	Resist roller solenoid/clutch operation check
	10	1st tray semicircular roller cleaning
07	01	Warm-up display and aging with jam
	06	Intermittent aging
	08	Shifting with warm-up display
08	01	Developing bias output
	02	Main charger output (Grid = HIGH)
	03	Main charger output (Grid = LOW)
	06	Transfer charger output
09	01	Duplex motor forward rotation check
	02	Duplex motor reverse rotation check
	04	Duplex motor RPM adjustment
	05	Duplex motor switchback time adjustment
10	-	Toner motor operation
14	-	Trouble cancel (except for U2)
16	-	U2 trouble cancel
20	01	Maintenance counter clear
21	01	Maintenance cycle setting
	02	Mini maintenance cycle setting
22	01	Maintenance counter display
	02	Maintenance preset display
	03	Jam memory display
	04	Jam total counter display
	05	Total counter display
	06	Developing counter display
	07	Mini maintenance preset display
	08	SPF counter display
	09	Paper feed counter display
	12	Drum counter display
	13	CRUM type display
	14	P-ROM version display
	15	Trouble memory display
	16	Duplex print counter display
	17	Copy counter display
	18	Printer counter display
	19	Scanner mode counter display
	21	Scanner counter display
22	SPF jam counter display	
50	Developer rotation time display	
51	Drum rotation time display	

Main code	Sub code	Contents	
24	01	Jam total counter clear	
	02	Trouble memory clear	
	04	SPF counter clear	
	05	Duplex print counter clear	
	06	Paper feed counter clear	
	07	Drum counter clear	
	08	Copy counter clear	
	09	Printer counter clear	
	13	Scanner counter clear	
	14	SPF jam total counter clear	
	15	Scanner mode counter clear	
	25	01	Main motor operation check
		02	Auto developer adjustment (Initial setting of toner density when replacing developer)
		10	Polygon motor operation check
	26	02	Size setting
03		Auditor setting	
04		Copier duplex setting	
05		Count mode setting	
06		Destination setting	
07		Machine condition check (CPM)	
18		Toner save mode setting	
30		CE mark conformity control ON/OFF	
31		Auditor mode exclusive setup	
36		Cancel of stop at maintenance life over	
37		Cancel of stop at developer life over	
38		Cancel of stop at drum life over	
39		Memory capacity check	
42		Transfer ON/OFF timing control setting	
43		Side void amount setting	
51		Copy temporary stop function setting	
54		Life correction ON/OFF setting	
69		Used to set the operating for toner end	
30	01	Paper sensor status display	
42	01	Developing counter clear	
43	01	Fusing temperature setting	
	02	Setting of item related to fusing temperature	
	03	Fusing temperature set value in preheating	
	04	Fusing temperature correction setting	
	10	Postcard paper feed cycle setting	
	12	Standby mode fusing fan rotation setting	
	13	Fusing paper interval control allow/inhibit setting	
44	01	Toner density control Enable/Disable (ON/OFF) setting	
	16	Toner density control data check and toner density control correction amount display	
	34	Transfer current setting	
46	02	Copy density adjustment (600dpi)	
	10	Copy exposure level adjustment, individual setting (Text) 600dpi	
	11	Copy exposure level adjustment, individual setting (Photo) 600dpi	
	19	Exposure mode setting (Gamma table setting/AUTO exposure operation mode setting/Photo image process setting)	
	20	SPF exposure correction	
	29	Image contrast adjustment (600dpi)	
	30	AUTO exposure limit setting	
	31	Image sharpness adjustment	

Main code	Sub code	Contents
48	01	Main/sub scanning magnification ratio adjustment
	05	RSPF mode sub scanning magnification ratio adjustment in copying
49	01	Flash ROM program writing mode
50	01	Image lead edge adjustment
	06	Copy lead edge position adjustment (RSPF)
	10	Paper off-center adjustment
	12	Document off-center adjustment
	18	Memory reverse position adjustment in duplex copy
	19	Rear edge void adjustment in duplex copy
51	02	Resist amount adjustment
53	08	SPF scanning position automatic adjustment
	10	SPF document scan position select setting
60	01	SDRAM (image memory area) access check
61	02	Laser power correction ON/OFF
	03	HSYNC output check
63	01	Shading check
	07	SPF automatic correction
64	01	Self print

## 4. Contents of simulations

Main code	Sub code	Contents	Details of operation																						
01	01	Mirror scanning operation	When the [START] key is pressed, the home position is checked in the first place, and the mirror base performs A3 full scanning once at the set magnification ratio speed. During this scanning, the set magnification ratio is displayed. The mirror home position sensor status is displayed with the developer replacement required indicator. (The lamp lights up when the mirror is in the home position.) During scanning, the copy lamp lights up. When the [Interrupt] key is pressed, the operation is interrupted to go to the sub code input standby mode.																						
	02	Mirror home position sensor (MHPS) status display	Used to monitor the mirror home position sensor. When the sensor is ON, the developer replacement required indicator is lighted. During that time, the display section displays the sub code. When the [Interrupt] key is pressed, the machine goes to the sub code input standby mode. (When the CA key is pressed, the simulation is terminated.)																						
	06	Mirror scanning operation aging	When the [START] key is pressed, the mirror base performs A3 full scanning at the set magnification ratio speed. During scanning, the set magnification ratio is displayed. After 3 seconds, the mirror base performs full scanning again. During scanning, the set magnification ratio is displayed. * When the [START] key is pressed again, the START indicator turns and remains off. The developer replacement required indicator displays the status of the mirror home position sensor. (The lamp lights up when the mirror is in the home position.) During aging, the copy lamp lights up. When the [Interrupt] key is pressed, the operation is interrupted if operating, and the machine goes into the sub code input standby mode.																						
02	01	Single paper feeder (SPF) aging (Only when the RSPF is installed)	When the [START] key is pressed, the set magnification ratio is acquired and document transport operation of single surface is performed in the case of SPF or document transport operation of duplex surfaces is performed in the case of RSPF. Since, however, there is no limited condition for this operation, it does not stop even at a paper jam. During operation, the LED on the display section corresponding to the selected magnification ratio lights up, and the magnification ratio is displayed on the 7-seg display. When the [Interrupt] key is pressed at that time, the machine goes to the sub code input standby mode. When the [CA] key is pressed, the simulation is terminated. <b>&lt;Conditions for executing this simulation&gt;</b> Set paper on the SPF and fix it with tape. If paper is not fixed, the operations cannot be guaranteed.																						
	02	SPF sensor status display (Only when the RSPF is installed)	(In order to receive the sensor change notification, the load must be decreased.) The sensor status (ON/OFF) in the SPF can be checked with the following lamps. When a sensor detects paper, it turns on. The open/close detection sensor turns on when the machine is opened. <table border="1" data-bbox="581 1094 1502 1396"> <thead> <tr> <th>LED</th> <th>Sensor</th> </tr> </thead> <tbody> <tr> <td>Toner cartridge replacement required indicator</td> <td>SPF document set sensor</td> </tr> <tr> <td>Misfeed indicator(Copier)</td> <td>SPF document transport sensor</td> </tr> <tr> <td>Developer replacement required indicator</td> <td>SPF unit (OC cover) open/close sensor</td> </tr> <tr> <td>Paper required indicator</td> <td>SPF paper exit sensor</td> </tr> <tr> <td>Misfeed indicator(SPF)</td> <td>SPF paper feed cover open/close sensor</td> </tr> <tr> <td>Bypass tray indicator</td> <td>SPF paper length sensor 1</td> </tr> <tr> <td>Misfeed indicator(1st Tray)</td> <td>SPF paper length sensor 2</td> </tr> <tr> <td>AUTO indicator</td> <td>SPF paper feed width sensor (small)</td> </tr> <tr> <td>TEXT indicator</td> <td>SPF paper feed width sensor (middle)</td> </tr> <tr> <td>PHOTO indicator</td> <td>SPF paper feed width sensor (large)</td> </tr> </tbody> </table>	LED	Sensor	Toner cartridge replacement required indicator	SPF document set sensor	Misfeed indicator(Copier)	SPF document transport sensor	Developer replacement required indicator	SPF unit (OC cover) open/close sensor	Paper required indicator	SPF paper exit sensor	Misfeed indicator(SPF)	SPF paper feed cover open/close sensor	Bypass tray indicator	SPF paper length sensor 1	Misfeed indicator(1st Tray)	SPF paper length sensor 2	AUTO indicator	SPF paper feed width sensor (small)	TEXT indicator	SPF paper feed width sensor (middle)	PHOTO indicator	SPF paper feed width sensor (large)
	LED	Sensor																							
Toner cartridge replacement required indicator	SPF document set sensor																								
Misfeed indicator(Copier)	SPF document transport sensor																								
Developer replacement required indicator	SPF unit (OC cover) open/close sensor																								
Paper required indicator	SPF paper exit sensor																								
Misfeed indicator(SPF)	SPF paper feed cover open/close sensor																								
Bypass tray indicator	SPF paper length sensor 1																								
Misfeed indicator(1st Tray)	SPF paper length sensor 2																								
AUTO indicator	SPF paper feed width sensor (small)																								
TEXT indicator	SPF paper feed width sensor (middle)																								
PHOTO indicator	SPF paper feed width sensor (large)																								
03	SPF motor operation check (Only when the RSPF is installed)	When the [START] key is pressed, the motor rotates for 10 sec at the speed corresponding to the set magnification ratio. When the [Interrupt] key is pressed, the machine stops operation and goes to the sub code input standby mode. When the [CA] key is pressed, the simulation is terminated.																							
08	SPF paper feed solenoid operation check (Only when the RSPF is installed)	The SPF paper feed solenoid (PSOL) is turned ON for 500msec and OFF for 500msec. This operation is repeated 20 times. After completion of the process, the machine goes to the sub code input standby mode. When the [Interrupt] key is pressed during the process, the machine goes to the sub code input standby mode. When the [CA] key is pressed, the simulation is terminated.																							
09	RSPF reverse solenoid operation check	The RSPF reverse solenoid (RSOL) is turned ON for 500msec and OFF for 500msec. This operation is repeated 20 times. After completion of the process, the machine goes to the sub code input standby mode. When the [Interrupt] key is pressed during the process, the machine goes to the sub code input standby mode. When the [CA] key is pressed, the simulation is terminated. This simulation is executable only when the RSPF is installed.																							
11	SPF PS release solenoid operation check	The SPF PS release solenoid (CLH) is turned ON for 500msec and OFF for 500msec. This operation is repeated 20 times. After completion of the process, the machine goes to the sub code input standby mode. When the [Interrupt] key is pressed during the process, the machine goes to the sub code input standby mode. When the [CA] key is pressed, the simulation is terminated.																							

Main code	Sub code	Contents	Details of operation																
05	01	Operation panel display check	<p><b>&lt;&lt;LED check mode (ALL ON/Individual ON)&gt;&gt;</b>  When the [START] key is pressed in the sub code input mode, all the LED's (including the 7-seg display) are turned ON. After 5 sec of all ON, the machine goes to the sub code input standby mode. When the [AUTO/TEXT/PHOTO] key is pressed during all ON, the lighting mode is shifted to the individual ON mode, where the LED's are individually lighted from the left top, to the left bottom, to the next line top, to the bottom, and so on. (For the 7-seg display, the 3-digit lamps are lighted at once.)  After completion of lighting of all the lamps, the mode is shifted to the all ON mode.  After 5 sec of all ON mode, the machine goes to the sub code input standby mode.</p> <table border="1"> <tr> <td>Individual ON mode cycle:</td> <td>300ms for ON</td> <td>20ms for OFF</td> </tr> </table> <p>When the [Interrupt] key is pressed in the LCD check mode, the machine goes back to the sub code input standby mode.  When the [CA] key is pressed, the simulation is terminated.  When the [START] key is pressed with all the lamps ON, the machine goes back to the key input check mode.</p> <p><b>&lt;&lt; Key input check mode&gt;&gt;</b>  When the machine goes into the key input check mode, [- - -] is displayed on the copy quantity display. Every time when a key on the operation panel is pressed, the input value is added on the copy quantity display.  [- - -] → [ 1 ] → [ 2 ] → ...  When a key is pressed once, it is not counted again.  When the [START] key is pressed, the input number is added and displayed for 3 sec, and the machine goes into the LED lighting check mode (LED all ON state). When the [Interrupt] key is pressed for the first time, it is counted. When the key is pressed for the second time, the machine goes into the sub code input mode. When the [CA] key is pressed for the first time, it is counted. When the key is pressed for the second time, the simulation is terminated. (Note for the key input check mode).  •Press the [START] key at the end. (When the key is pressed during the process, the machine goes into the LED lighting check mode (all ON state).).  •When two or more keys are pressed simultaneously, they are ignored.</p>	Individual ON mode cycle:	300ms for ON	20ms for OFF													
Individual ON mode cycle:	300ms for ON	20ms for OFF																	
	02	Fusing lamp and cooling fan operation check	<p>When the [START] key is pressed, the fusing lamp turns ON for 500ms and OFF for 500ms. The operation is repeated 5 times. During this process, the cooling fan motor rotates. After completion of the process, the machine goes into the sub code input standby mode.</p>																
	03	Copy lamp lighting check	<p>When the [START] key is pressed, the copy lamp lights up for 5 sec. After completion of lighting, the machine goes into the sub code input mode.  When the [Interrupt] key is pressed, the process is interrupted and the machine goes into the sub code input standby mode. When the [CA] key is pressed, the simulation is terminated.</p>																
06	01	Paper feed solenoid/clutch operation check	<p>When this simulation is executed, the sub code is displayed on the 7-seg display and the lamp corresponding to the solenoid/clutch lights up.  Select a solenoid/clutch with the [TRAY SETTING] key (the lamp corresponding to the solenoid/clutch lights up) and press the [START] key, and the machine repeats operation of ON for 500ms and OFF for 500ms.  This operation is repeated 20 times.  After that, the machine goes into the sub code entry standby mode.</p> <table border="1"> <thead> <tr> <th>LED</th> <th>Solenoid</th> </tr> </thead> <tbody> <tr> <td>Main tray indicator</td> <td>1st tray paper feed solenoid/clutch</td> </tr> <tr> <td>2nd tray indicator</td> <td>* 2nd tray paper feed solenoid/clutch</td> </tr> <tr> <td>3rd tray indicator</td> <td>* 3rd tray paper feed solenoid/clutch</td> </tr> <tr> <td>4th tray indicator</td> <td>* 4th tray paper feed solenoid/clutch</td> </tr> <tr> <td>Bypass tray indicator</td> <td>Bypass tray solenoid</td> </tr> <tr> <td>Misfeed indicator(2nd tray)</td> <td>* 2nd tray transport solenoid/clutch</td> </tr> <tr> <td>Misfeed indicator(Copier) &amp; Misfeed indicator(2nd tray)</td> <td>* 3rd tray transport solenoid/clutch</td> </tr> </tbody> </table>	LED	Solenoid	Main tray indicator	1st tray paper feed solenoid/clutch	2nd tray indicator	* 2nd tray paper feed solenoid/clutch	3rd tray indicator	* 3rd tray paper feed solenoid/clutch	4th tray indicator	* 4th tray paper feed solenoid/clutch	Bypass tray indicator	Bypass tray solenoid	Misfeed indicator(2nd tray)	* 2nd tray transport solenoid/clutch	Misfeed indicator(Copier) & Misfeed indicator(2nd tray)	* 3rd tray transport solenoid/clutch
LED	Solenoid																		
Main tray indicator	1st tray paper feed solenoid/clutch																		
2nd tray indicator	* 2nd tray paper feed solenoid/clutch																		
3rd tray indicator	* 3rd tray paper feed solenoid/clutch																		
4th tray indicator	* 4th tray paper feed solenoid/clutch																		
Bypass tray indicator	Bypass tray solenoid																		
Misfeed indicator(2nd tray)	* 2nd tray transport solenoid/clutch																		
Misfeed indicator(Copier) & Misfeed indicator(2nd tray)	* 3rd tray transport solenoid/clutch																		
	02	Resist roller solenoid/clutch operation check	<p>When the [START] key is pressed in the sub code input state, the resist solenoid/clutch (RRS) turns ON for 500ms and OFF for 500ms. This operation is repeated 20 times.  After completion of the process, the machine goes into the sub code input standby mode.</p>																
	10	1st tray semicircular roller cleaning	<p>The main motor is rotated to rotate the semicircular roller of the 1st tray one turn to face the semicircular roller down. (Remove the developing layer when performing this operation.)  During this process, the sub code is displayed on the display section.  After completion of the process, the machine goes into the sub code input standby mode.</p>																

Main code	Sub code	Contents	Details of operation											
07	01	Warm-up display and aging with jam	Copying is repeated to make the set copy quantity. When this simulation is executed, warm-up is started and warm-up time is counted up every second from 0 and displayed. After completion of warm-up, warm-up time count is stopped. When the [CA] key is pressed, the START indicator lights up. After that, when the copy quantity is inputted with keys and the [START] key is pressed, copying is repeated to make the set copy quantity. (Intermittent 0 sec) This simulation is canceled by turning off the power or performing a simulation that executes hardware reset.											
	06	Intermittent aging	Copying is repeated to make the set copy quantity. When this simulation is performed, warm-up is performed and the START indicator is lighted. Enter the copy quantity with the key and press the [START] key, and copying is repeated to make the set copy quantity, the ready state remains for 3 sec, and copying is repeated again to make the set copy quantity. These operations are repeated. This simulation is canceled by turning off the power or performing a simulation that executes hardware reset.											
	08	Shifting with warm-up display (Shifting similar to pressing the CA key)	When the simulation code is entered, warm-up is started and warm-up time is counted up every second from 0 and displayed. When the [CA] key is pressed during counting up, the display section displays "0" and count-up process stops. However, warm-up is continued. After completion of warm-up, counting is stopped. Press the [CA] key to terminate the simulation mode. (This simulation is similar to SIM07-01, but without the aging function.)											
08	01	Developing bias output	When the [START] key is pressed, the developing bias signal is turned ON for 30 sec. However, to calculate the actual output value is calculated, execute SIM25-01. After completion of the process, the machine goes into the sub code input standby mode.											
	02	Main charger output (Grid = HIGH)	When the [START] key is pressed, the main charger output is supplied for 30 sec in the grid voltage HIGH mode. After completion of the process, the machine goes into the sub code input standby mode.											
	03	Main charger output (Grid = LOW)	When the [START] key is pressed, the main charger output is supplied for 30 sec in the grid voltage LOW mode. After completion of the process, the machine goes into the sub code input standby mode.											
	06	Transfer charger output	Select an output mode with the [AUTO/TEXT/PHOTO] key and press the [START] key. The transfer charger output is delivered for 30 sec in the selected mode. After 30 sec of transfer charger output, the machine goes into the sub code entry standby mode. <table border="1" style="width: 100%; border-collapse: collapse;"> <thead> <tr> <th style="width: 50%;">LED</th> <th style="width: 50%;">Output mode</th> </tr> </thead> <tbody> <tr> <td>AUTO indicator</td> <td>Normal size width: Front surface</td> </tr> <tr> <td>TEXT indicator</td> <td>Normal size width: Back surface*</td> </tr> <tr> <td>AUTO indicator &amp; PHOTO indicator</td> <td>Small size width: Front surface</td> </tr> <tr> <td>TEXT indicator &amp; PHOTO indicator</td> <td>Small size width: Back surface*</td> </tr> <tr> <td>AUTO &amp; TEXT &amp; PHOTO indicator</td> <td>Bypass tray indicator mode</td> </tr> </tbody> </table> <p>•Small size is Letter R (A4R) or smaller. * Duplex model only</p>	LED	Output mode	AUTO indicator	Normal size width: Front surface	TEXT indicator	Normal size width: Back surface*	AUTO indicator & PHOTO indicator	Small size width: Front surface	TEXT indicator & PHOTO indicator	Small size width: Back surface*	AUTO & TEXT & PHOTO indicator
LED	Output mode													
AUTO indicator	Normal size width: Front surface													
TEXT indicator	Normal size width: Back surface*													
AUTO indicator & PHOTO indicator	Small size width: Front surface													
TEXT indicator & PHOTO indicator	Small size width: Back surface*													
AUTO & TEXT & PHOTO indicator	Bypass tray indicator mode													
09	01	Duplex motor forward rotation check (Duplex model only)	The duplex motor is driven in forward direction (in the paper exit direction) for 30 sec. During the process, the display section displays the sub code. After completion of the process, the machine goes into the sub code input standby mode. When the [Interrupt] key is pressed, the machine goes into the sub code input standby mode. When the [CA] key is pressed, the simulation is terminated.											
	02	Duplex motor reverse rotation check (Duplex model only)	The duplex motor is driven in reverse direction for 30 sec. During the process, the display section displays the sub code. After completion of the process, the machine goes into the sub code input standby mode. When the [Interrupt] key is pressed, the machine goes into the sub code input standby mode. When the [CA] key is pressed, the simulation is terminated.											
	04	Duplex motor RPM adjustment (Duplex model only)	When any key input is made, it is displayed on the display section. When the [START] key is pressed, the set code data are acquired and stored in the EEPROM, and the machine goes into the sub code input standby mode. When, however, the [START] key is pressed outside the set range, it is not assured. <table border="1" style="width: 100%; border-collapse: collapse;"> <tr> <td style="width: 60%;">Set range: 1 - 13</td> <td style="width: 40%;">Default: 4</td> </tr> </table> <p>At that time, when the [Interrupt] key is pressed, the data are not rewritten and the machine goes into the sub code input standby mode. When the [CA] key is pressed, the simulation is terminated without rewriting the data.</p>	Set range: 1 - 13	Default: 4									
	Set range: 1 - 13	Default: 4												
	05	Duplex motor switchback time adjustment (Duplex model only)	When any key input is made, it is displayed on the display section. When the [START] key is pressed, the set code data are acquired and stored in the EEPROM, and the machine goes into the sub code input standby mode. <table border="1" style="width: 100%; border-collapse: collapse;"> <tr> <td style="width: 60%;">Set range: 50 ~ 76</td> <td style="width: 40%;">Default: 50</td> </tr> </table> <p>(Change quantity 1 → 1-2 phase 3 steps)</p> <p>At that time, when the [Interrupt] key is pressed, the data are not rewritten and the machine goes into the sub code input standby mode. When the [CA] key is pressed, the simulation is terminated without rewriting the data.</p>	Set range: 50 ~ 76	Default: 50									
Set range: 50 ~ 76	Default: 50													

Main code	Sub code	Contents	Details of operation																			
10	-	Toner motor operation	When the [START] key is pressed, the toner motor is driven for 30 sec. After completion of the process, the machine goes into the main code input standby mode. When the [Interrupt] key is pressed, the machine goes into the main code input standby mode.																			
14	-	Trouble cancel (except for U2)	* Trouble to write into the EEPROM such as H trouble is canceled and hardware reset is performed.																			
16	-	U2 trouble cancel	* U2 trouble is canceled and hardware reset is performed.																			
20	01	Maintenance counter clear	When the [START] key is pressed, the maintenance count value is cleared and "000000" is displayed. (Alternate display of "000" and "000")																			
21	01	Maintenance cycle setting	The current set maintenance cycle code is displayed (initial display), and the set data are stored. <table border="1" style="width: 100%; border-collapse: collapse;"> <thead> <tr> <th style="width: 30%;">Code</th> <th style="width: 70%;">Setting</th> </tr> </thead> <tbody> <tr> <td>0</td> <td>5,000 sheets</td> </tr> <tr> <td>1</td> <td>7,500 sheets</td> </tr> <tr> <td>2</td> <td>10,000 sheets</td> </tr> <tr> <td>3</td> <td>25,000 sheets</td> </tr> <tr> <td>4</td> <td>50,000 sheets * Default</td> </tr> <tr> <td>5</td> <td>Free (999,999 sheets)</td> </tr> </tbody> </table>	Code	Setting	0	5,000 sheets	1	7,500 sheets	2	10,000 sheets	3	25,000 sheets	4	50,000 sheets * Default	5	Free (999,999 sheets)					
	Code	Setting																				
0	5,000 sheets																					
1	7,500 sheets																					
2	10,000 sheets																					
3	25,000 sheets																					
4	50,000 sheets * Default																					
5	Free (999,999 sheets)																					
02	Mini maintenance cycle setting (Valid only when the destination is set to Japan AB series.)	The current set maintenance cycle code is displayed (initial display), and the set data are stored. <table border="1" style="width: 100%; border-collapse: collapse;"> <thead> <tr> <th style="width: 30%;">Code</th> <th style="width: 70%;">Setting</th> </tr> </thead> <tbody> <tr> <td>0</td> <td>5,000 sheets * Default</td> </tr> <tr> <td>1</td> <td>10,000 sheets</td> </tr> <tr> <td>2</td> <td>Free (999,999 sheets)</td> </tr> </tbody> </table>	Code	Setting	0	5,000 sheets * Default	1	10,000 sheets	2	Free (999,999 sheets)												
Code	Setting																					
0	5,000 sheets * Default																					
1	10,000 sheets																					
2	Free (999,999 sheets)																					
22	01	Maintenance counter display	The maintenance counter value is displayed.																			
	02	Maintenance preset display (Valid only when the destination is set to EX Japan)	The copy quantity corresponding to the code that is set with SIM21-01 is displayed. (For example: 50,000 sheets)																			
	03	Jam memory display	The LED of the latest jam position is lighted. Every time when the [PRESET RATIO selector] keys is pressed, the jam memory data is acquired sequentially from the latest. The jam position is judged by the acquired data and the corresponding LED is lighted. The 7-seg display indicates the jam number. At that time, "A" is displayed on the upper first digit. When the last one is displayed, the latest one will be displayed again. Max. 30 jams from the latest are stored. When the [Interrupt] key is pressed, the machine goes into the sub code input standby mode. When the [CA] key is pressed, the simulation is terminated.																			
	04	Jam total counter display	The jam total counter value is displayed.																			
	05	Total counter display	The total counter value is displayed.																			
	06	Developing counter display	The developing counter data is acquired and displayed on the 7-seg display. When the [Interrupt] key is pressed, the machine goes into the sub code input standby mode. When the [CA] key is pressed, the simulation is terminated.																			
	07	Mini maintenance preset display (Valid only when the destination is set to Japan AB series)	The mini maintenance cycle data is acquired and displayed on the 7-seg display. When the [Interrupt] key is pressed, the machine goes into the sub code input standby mode. When the [CA] key is pressed, the simulation is terminated.																			
	08	SPF counter display	The SPF counter value is displayed.																			
	09	Paper feed counter display	The counter value of the selected paper feed section is acquired from each variable, the data is displayed on the 7-seg display according to the regulations. When this simulation is executed, the value of the 1st paper tray is displayed first. Press the [TRAY SETTING] key to select the tray. When the [Interrupt] key is pressed, the machine goes into the sub code input standby mode. When the [CA] key is pressed, the simulation is terminated.																			
	12	Drum counter display	The drum counter and the drum rotating time are displayed. To change the display mode, press the [AUTO/TEXT/PHOTO] key. <table border="1" style="width: 100%; border-collapse: collapse;"> <thead> <tr> <th style="width: 60%;">LED</th> <th style="width: 40%;">Display mode</th> </tr> </thead> <tbody> <tr> <td>AUTO exposure indicator</td> <td>Drum counter</td> </tr> <tr> <td>TEXT indicator</td> <td>Drum rotating time</td> </tr> </tbody> </table>	LED	Display mode	AUTO exposure indicator	Drum counter	TEXT indicator	Drum rotating time													
	LED	Display mode																				
	AUTO exposure indicator	Drum counter																				
	TEXT indicator	Drum rotating time																				
13	CRUM destination display	When this simulation is executed, the CRUM destination set (written) in the CRUM chip is displayed. This simulation is valid only for the models where the CRUM is valid. <table border="1" style="width: 100%; border-collapse: collapse;"> <thead> <tr> <th style="width: 25%;">7-seg display</th> <th style="width: 25%;">Meaning (CRUM destination)</th> <th style="width: 25%;">7-seg display</th> <th style="width: 25%;">Meaning (CRUM destination)</th> </tr> </thead> <tbody> <tr> <td>00</td> <td>Not set yet</td> <td>04</td> <td>CHN-A</td> </tr> <tr> <td>01</td> <td>BTA-A</td> <td>05</td> <td>JPN_A</td> </tr> <tr> <td>02</td> <td>BTA-B</td> <td>06</td> <td>BTA_F</td> </tr> <tr> <td>03</td> <td>BTA-C</td> <td>99</td> <td>Conversion</td> </tr> </tbody> </table>	7-seg display	Meaning (CRUM destination)	7-seg display	Meaning (CRUM destination)	00	Not set yet	04	CHN-A	01	BTA-A	05	JPN_A	02	BTA-B	06	BTA_F	03	BTA-C	99	Conversion
7-seg display	Meaning (CRUM destination)	7-seg display	Meaning (CRUM destination)																			
00	Not set yet	04	CHN-A																			
01	BTA-A	05	JPN_A																			
02	BTA-B	06	BTA_F																			
03	BTA-C	99	Conversion																			

Main code	Sub code	Contents	Details of operation						
22	14	P-ROM version display	<p>The P-ROM version is displayed on the copy quantity display. The main code and the sub code are alternatively displayed by 2 digits. The display interval is same as that of the counter display.</p> <table border="1"> <thead> <tr> <th>LED (AB series)</th> <th>LED (Inch series)</th> <th>Displayed version</th> </tr> </thead> <tbody> <tr> <td>141%</td> <td>141%</td> <td>Machine program</td> </tr> </tbody> </table>	LED (AB series)	LED (Inch series)	Displayed version	141%	141%	Machine program
LED (AB series)	LED (Inch series)	Displayed version							
141%	141%	Machine program							
	15	Trouble memory display	<p>The trouble codes are acquired from the trouble memory data.  Every time when the magnification ratio display is pressed, the main code of the trouble is displayed on the 1st ~ 2nd digit.  * The latest 20 troubles are stored in the memory.  The 3rd digit indicates the trouble history code, "A" ~ "J" (meaning of 1 ~ 10).  After "J" is displayed, "A" ~ "J" blinks. (Meaning of 11 ~ 20)  After "J" blinks (meaning of 20), "A" ~ "J" is lighted. (Returns to 1.)  When the [START] key is pressed, the sub code is displayed.  When the [Interrupt] key is pressed, the machine goes into the sub code input standby mode.  When the [CA] key is pressed, the simulation is terminated.  * Note that when the history code blinks, the trouble code and the sub code do not blink.</p>						
	16	Duplex print counter display (Duplex model only)	<p>Data is acquired from the duplex print counter variable, and is displayed.  When the [Interrupt] key is pressed, the machine goes into the sub code input standby mode.  When the [CA] key is pressed, the simulation is terminated.</p>						
	17	Copy counter display	<p>The copy counter value is displayed. When the [Interrupt] key is pressed, the machine goes into the sub code input standby mode. When the [CA] key is pressed, the simulation is terminated.</p>						
	18	Printer counter display	<p>The printer counter value is displayed. When the [Interrupt] key is pressed, the machine goes into the sub code input standby mode. When the [CA] key is pressed, the simulation is terminated.</p>						
	19	Scanner mode counter display (Except for AR-5618S/AR-5620S)	<p>The scanner mode counter value is displayed. When the [Interrupt] key is pressed, the machine goes into the sub code input standby mode. When the [CA] key is pressed, the simulation is terminated.</p>						
	21	Scanner counter display	<p>The scanner counter value is displayed. When the [Interrupt] key is pressed, the machine goes into the sub code input standby mode. When the [CA] key is pressed, the simulation is terminated.</p>						
	22	SPF jam counter display (Only when the RSPF is installed)	<p>The SPF jam counter value is displayed. When the [Interrupt] key is pressed, the machine goes into the sub code input standby mode. When the [CA] key is pressed, the simulation is terminated.</p>						
	50	Developer rotation time display	<p>The developer rotation time is displayed. (Three digits are displayed alternatively.)  When [Interrupt] key is pressed, the display goes to the sub code input standby state. When [CA] key is pressed, the machine goes out of the simulation mode.</p>						
	51	Drum rotation time display	<p>The drum rotation time is displayed. (Three digits are displayed alternatively.)  When [Interrupt] key is pressed, the display goes to the sub code input standby state. When [CA] key is pressed, the machine goes out of the simulation mode.</p>						

Main code	Sub code	Contents	Details of operation						
24	01	Jam total counter clear	When the [START] key is pressed, the jam total count value is reset to zero, and zero is displayed.						
	02	Trouble memory clear	The trouble memory and the EEPROM trouble history data are cleared and "000" is displayed on the 7-seg display. When the [Interrupt] key is pressed, the machine goes into the sub code input standby mode. When the [CA] key is pressed, the simulation is terminated.						
	04	SPF counter clear (Only when the RSPF is installed)	When the [START] key is pressed, the SPF count value is reset to zero and displayed on the 7-seg display. When the [Interrupt] key is pressed, the machine goes into the sub code input standby mode. When the [CA] key is pressed, the simulation is terminated.						
	05	Duplex print counter clear (Duplex model only)	The duplex print count data is cleared, and zero is displayed on the 7-seg display. When the [Interrupt] key is pressed, the machine goes into the sub code input standby mode. When the [CA] key is pressed, the simulation is terminated.						
	06	Paper feed counter clear	The paper feed counter data of each paper feed section is cleared, and "000" is displayed on the 7-seg display. When the [Interrupt] key is pressed, the machine goes into the sub code input standby mode. When the [CA] key is pressed, the simulation is terminated.						
	07	Drum counter clear	When the [START] key is pressed, the drum count and the drum rotation time are reset to zero, and the drum counter value is displayed on the 7-seg display. When the [Interrupt] key is pressed, the machine goes into the sub code input standby mode. When the [CA] key is pressed, the simulation is terminated.						
	08	Copy counter clear	When the [START] key is pressed, the copy count value is reset to zero and displayed on the 7-seg display. When the [Interrupt] key is pressed, the machine goes into the sub code input standby mode. When the [CA] key is pressed, the simulation is terminated.						
	09	Printer counter clear	When the [START] key is pressed, the printer count value is reset to zero and displayed on the 7-seg display. When the [Interrupt] key is pressed, the machine goes into the sub code input standby mode. When the [CA] key is pressed, the simulation is terminated.						
	13	Scanner counter clear	When the [START] key is pressed, the scanner count value is reset to zero and displayed on the 7-seg display. When the [Interrupt] key is pressed, the machine goes into the sub code input standby mode. When the [CA] key is pressed, the simulation is terminated.						
	14	SPF jam total counter clear (Only when the RSPF is installed)	When the [START] key is pressed, the SPF jam total count value is reset to zero and displayed on the 7-seg display. When the [Interrupt] key is pressed, the machine goes into the sub code input standby mode. When the [CA] key is pressed, the simulation is terminated.						
	15	Scanner mode counter clear (Except for AR-5618S/AR-5620S)	When the [START] key is pressed, the scanner mode count value is reset to zero and displayed on the 7-seg display. When the [Interrupt] key is pressed, the machine goes into the sub code input standby mode. When the [CA] key is pressed, the simulation is terminated.						
25	01	Main motor operation check (Cooling fan motor rotation check)	When the [START] key is pressed, the main motor (together with the duplex motor for the duplex model) is driven for 30 sec. At that time, to save toner consumption, if the developing unit is installed, the developing bias, the main charger, and the grid are outputted. Since, in that case, laser discharge is required when the motor stops, the polygon motor is driven simultaneously. Check if the developing unit is installed or not. If it is not installed, the above high voltage is not outputted and only the motor is rotated. After completion of 30 sec operation, the machine goes into the sub code input standby mode. * This simulation must not be executed by forcibly turning on the door open/close switch.						
	02	Auto developer adjustment (Initial setting of toner density when replacing developer)	To execute this simulation, the following procedures must be performed.  <Procedures> 1) Turn OFF the power of the machine. 2) Open the front cover. 3) Install the DV unit and toner cartridge. 4) Turn ON the power of the machine with the cover opened. 5) Enter Sim25-02. (Entered value display section: "CH" is displayed. Start LED: OFF) 6) Close the front cover. (Entered value display section: "--" is displayed. Start LED: ON) 7) Press [START] key to execute Sim25-02.  When [START] key is pressed, the main motor rotates for 3 minutes to determine the toner sensor reference value and clear the developer rotation time as well as to clear the developer counter.  When the operation is completed normally, the ATC sensor reference value is displayed on the entered value display section. If an error occurs, one of the following indicators is lighted. <table border="1" data-bbox="581 1696 1502 1780"> <thead> <tr> <th>LED</th> <th>Display mode</th> </tr> </thead> <tbody> <tr> <td>Misfeed indicator</td> <td>EL trouble</td> </tr> <tr> <td>Paper required indicator</td> <td>EU trouble</td> </tr> </tbody> </table> This simulation must be executed only immediately after installing developer. Do not execute this simulation for any developer which has been used. If the machine goes into the warm-up state before completion of this simulation, there is a possibility that toner may be supplied to the developer during warm-up. In such a case, therefore, the developer must be replaced with new one.	LED	Display mode	Misfeed indicator	EL trouble	Paper required indicator	EU trouble
	LED	Display mode							
Misfeed indicator	EL trouble								
Paper required indicator	EU trouble								
10	Polygon motor operation check	When the [START] key is pressed, the polygon motor is rotated for 30 sec. After completion of 30 sec operation, the machine goes into the sub code input standby mode.							

Main code	Sub code	Contents	Details of operation																														
26	02	Size setting	<p>Used to set Enable/Disable of the FC (8.5" x 13") size detection.</p> <table border="1"> <thead> <tr> <th>Code number</th> <th>Setting</th> </tr> </thead> <tbody> <tr> <td>0</td> <td>FC detection Disable * Default for destinations excluding the following</td> </tr> <tr> <td>1</td> <td>FC detection Enable * Default for only Australia, New Zealand, and the Philippines.</td> </tr> </tbody> </table> <p>Detection size when a document of the FC ((8.5" x 13") size is used</p> <table border="1"> <thead> <tr> <th rowspan="2"></th> <th rowspan="2">Unit to be used</th> <th rowspan="2">Destination</th> <th rowspan="2">Document size</th> <th colspan="2">Setting</th> </tr> <tr> <th>0 (Disable)</th> <th>1 (Enable)</th> </tr> </thead> <tbody> <tr> <td rowspan="4">Document</td> <td rowspan="2">SPF</td> <td rowspan="2">EX Japan AB series (FC)</td> <td>FC (8.5" x 13")</td> <td>B4</td> <td>FC (8.5" x 13")</td> </tr> <tr> <td>B4</td> <td>B4</td> <td>FC (8.5" x 13")</td> </tr> <tr> <td rowspan="2">Inch series (FC)</td> <td>FC (8.5" x 13")</td> <td>LG (8.5" x 14")</td> <td>FC (8.5" x 13")</td> </tr> <tr> <td>LG (8.5" x 14")</td> <td>LG (8.5" x 14")</td> <td>FC (8.5" x 13")</td> </tr> </tbody> </table> <p>•For the other destinations, this setting is disabled.</p>	Code number	Setting	0	FC detection Disable * Default for destinations excluding the following	1	FC detection Enable * Default for only Australia, New Zealand, and the Philippines.		Unit to be used	Destination	Document size	Setting		0 (Disable)	1 (Enable)	Document	SPF	EX Japan AB series (FC)	FC (8.5" x 13")	B4	FC (8.5" x 13")	B4	B4	FC (8.5" x 13")	Inch series (FC)	FC (8.5" x 13")	LG (8.5" x 14")	FC (8.5" x 13")	LG (8.5" x 14")	LG (8.5" x 14")	FC (8.5" x 13")
Code number	Setting																																
0	FC detection Disable * Default for destinations excluding the following																																
1	FC detection Enable * Default for only Australia, New Zealand, and the Philippines.																																
	Unit to be used	Destination	Document size	Setting																													
				0 (Disable)	1 (Enable)																												
Document	SPF	EX Japan AB series (FC)	FC (8.5" x 13")	B4	FC (8.5" x 13")																												
			B4	B4	FC (8.5" x 13")																												
	Inch series (FC)	FC (8.5" x 13")	LG (8.5" x 14")	FC (8.5" x 13")																													
		LG (8.5" x 14")	LG (8.5" x 14")	FC (8.5" x 13")																													
03	Auditor setting	<p>Used to set the auditor.</p> <table border="1"> <thead> <tr> <th>Code number</th> <th>Mode</th> </tr> </thead> <tbody> <tr> <td>0</td> <td>Built-in auditor mode *Default</td> </tr> <tr> <td>1</td> <td>Coin vendor mode</td> </tr> <tr> <td>2</td> <td>Other</td> </tr> </tbody> </table> <p>* When the coin vendor mode is selected, if the auditor setup is ON and the default tray is bypass tray, the default tray setup must be changed to the 1st tray.</p>	Code number	Mode	0	Built-in auditor mode *Default	1	Coin vendor mode	2	Other																							
Code number	Mode																																
0	Built-in auditor mode *Default																																
1	Coin vendor mode																																
2	Other																																
04	Copier duplex setting	<p>When this simulation is executed, the current set duplex code number is displayed. Enter the desired code number of duplex setting and press the [START] key, and the entered code number is set.</p> <table border="1"> <thead> <tr> <th>Code number</th> <th>Mode</th> </tr> </thead> <tbody> <tr> <td>0</td> <td>Without duplex</td> </tr> <tr> <td>1</td> <td>With duplex</td> </tr> </tbody> </table> <p>* When this simulation is executed, the binding margin setup is automatically set to the default (left side).</p>	Code number	Mode	0	Without duplex	1	With duplex																									
Code number	Mode																																
0	Without duplex																																
1	With duplex																																
05	Count mode setting	<p>When any key input is made, it is displayed on the display section. When the [START] key is pressed, the set code data are acquired and stored to the count mode set variable and in the EEPROM, and the machine goes into the sub code input standby mode. However, if the [START] key is pressed outside the set range, it is not assured. At that time, when the [Interrupt] key is pressed, the data is not rewritten and the machine goes into the sub code input standby mode. When the [CA] key is pressed, the simulation is terminated without rewriting the data.</p> <p>[*1 : Total counter / Developer counter    *2 : maintenance counter]</p> <table border="1"> <tbody> <tr> <td>0:</td> <td>*1= Double count</td> <td>*2= Double count</td> <td>*Default</td> </tr> <tr> <td>1:</td> <td>*1= Single count</td> <td>*2 = Double count</td> <td></td> </tr> <tr> <td>2:</td> <td>*1= Double count</td> <td>*2= Single count</td> <td></td> </tr> <tr> <td>3:</td> <td>*1= Single count</td> <td>*2= Single count</td> <td></td> </tr> </tbody> </table>	0:	*1= Double count	*2= Double count	*Default	1:	*1= Single count	*2 = Double count		2:	*1= Double count	*2= Single count		3:	*1= Single count	*2= Single count																
0:	*1= Double count	*2= Double count	*Default																														
1:	*1= Single count	*2 = Double count																															
2:	*1= Double count	*2= Single count																															
3:	*1= Single count	*2= Single count																															
06	Destination setting	<p>When this simulation is executed, the current set destination code number is displayed. Enter the desired code number of the destination and press the [START] key to set the destination.</p> <table border="1"> <thead> <tr> <th>Code number</th> <th>Destination</th> </tr> </thead> <tbody> <tr> <td>0</td> <td>Japan AB series</td> </tr> <tr> <td>1</td> <td>Inch series</td> </tr> <tr> <td>2</td> <td>EX Japan AB series</td> </tr> <tr> <td>3</td> <td>EX Japan inch series(FC)</td> </tr> <tr> <td>4</td> <td>EX Japan AB series (FC)</td> </tr> <tr> <td>5</td> <td>China (EX Japan AB series + China paper support)</td> </tr> <tr> <td>6</td> <td>Taiwan (EX Japan AB series + China paper support)</td> </tr> </tbody> </table> <p>If this setting is changed, SIM46-19 setting is also changed accordingly.  (The paper size is also changed: AB series is changed to A4, and Inch series to Letter.  The AUTO exposure limit setup is set to the default.  When the destination is changed (from Japan to EX Japan or from EX Japan to Japan), the maintenance cycle is also set to the default accordingly.)</p>	Code number	Destination	0	Japan AB series	1	Inch series	2	EX Japan AB series	3	EX Japan inch series(FC)	4	EX Japan AB series (FC)	5	China (EX Japan AB series + China paper support)	6	Taiwan (EX Japan AB series + China paper support)															
Code number	Destination																																
0	Japan AB series																																
1	Inch series																																
2	EX Japan AB series																																
3	EX Japan inch series(FC)																																
4	EX Japan AB series (FC)																																
5	China (EX Japan AB series + China paper support)																																
6	Taiwan (EX Japan AB series + China paper support)																																
07	Machine condition check (CPM)	<p>When this simulation is executed, the current setting of the machine is displayed.</p> <table border="1"> <thead> <tr> <th>7-seg display</th> <th>Meaning (CPM information)</th> </tr> </thead> <tbody> <tr> <td>18</td> <td>18CPM</td> </tr> <tr> <td>20</td> <td>20CPM</td> </tr> <tr> <td>23</td> <td>23CPM</td> </tr> </tbody> </table>	7-seg display	Meaning (CPM information)	18	18CPM	20	20CPM	23	23CPM																							
7-seg display	Meaning (CPM information)																																
18	18CPM																																
20	20CPM																																
23	23CPM																																

Main code	Sub code	Contents	Details of operation									
26	18	Toner save mode setting	<p>Used to set ON/OFF of the toner save mode.</p> <table border="1"> <thead> <tr> <th>Code number</th> <th>Setting</th> </tr> </thead> <tbody> <tr> <td>0</td> <td>Toner save OFF</td> </tr> <tr> <td>1</td> <td>Toner save ON</td> </tr> </tbody> </table> <p>* The toner save mode of the user program is also changed accordingly. The default value depends on the destination.</p>	Code number	Setting	0	Toner save OFF	1	Toner save ON			
Code number	Setting											
0	Toner save OFF											
1	Toner save ON											
	30	CE mark conformity control ON/OFF	<p>When this simulation is executed, the current set code number of CE mark conformity is displayed. Enter the desired code number of CE mark conformity and press the [START] key to set the code number.</p> <table border="1"> <thead> <tr> <th>Code number</th> <th>Setting</th> </tr> </thead> <tbody> <tr> <td>0</td> <td>CE mark conformity control OFF *Default for 100V system</td> </tr> <tr> <td>1</td> <td>CE mark conformity control ON *Default for 200V system</td> </tr> </tbody> </table>	Code number	Setting	0	CE mark conformity control OFF *Default for 100V system	1	CE mark conformity control ON *Default for 200V system			
Code number	Setting											
0	CE mark conformity control OFF *Default for 100V system											
1	CE mark conformity control ON *Default for 200V system											
	31	Auditor mode exclusive setup	<p>Used to set whether the bypass tray can be used or not when the auditor mode is set to the coin vendor mode.</p> <table border="1"> <thead> <tr> <th>Code number</th> <th>Setting</th> </tr> </thead> <tbody> <tr> <td>0</td> <td>Exclusive setup OFF (Bypass tray paper feed allowed)</td> </tr> <tr> <td>1</td> <td>Exclusive setup ON (Bypass tray paper feed inhibited)*Default</td> </tr> <tr> <td>3</td> <td>Exclusive setup OFF (Bypass tray paper feed inhibited) (Double amount of that when set to "0" is charged.)</td> </tr> </tbody> </table> <p>* When this is set to "Exclusive setup ON," if the auditor is set to the coin vendor mode and the default tray is set to the bypass tray, the default tray must be reset to the 1st tray.</p>	Code number	Setting	0	Exclusive setup OFF (Bypass tray paper feed allowed)	1	Exclusive setup ON (Bypass tray paper feed inhibited)*Default	3	Exclusive setup OFF (Bypass tray paper feed inhibited) (Double amount of that when set to "0" is charged.)	
Code number	Setting											
0	Exclusive setup OFF (Bypass tray paper feed allowed)											
1	Exclusive setup ON (Bypass tray paper feed inhibited)*Default											
3	Exclusive setup OFF (Bypass tray paper feed inhibited) (Double amount of that when set to "0" is charged.)											
	36	Cancel of stop at maintenance life over	<p>Used to set stop at maintenance life over.</p> <table border="1"> <thead> <tr> <th>Code number</th> <th>Setting</th> </tr> </thead> <tbody> <tr> <td>0</td> <td>Stop at maintenance life over</td> </tr> <tr> <td>1</td> <td>Cancel of stop at maintenance life over * Default</td> </tr> </tbody> </table>	Code number	Setting	0	Stop at maintenance life over	1	Cancel of stop at maintenance life over * Default			
Code number	Setting											
0	Stop at maintenance life over											
1	Cancel of stop at maintenance life over * Default											
	37	Cancel of stop at developer life over	<p>When this simulation is executed, the current set code number is displayed. Enter the desired code number and press the [START] key to set the code number. The machine goes into the sub code input state.</p> <table border="1"> <thead> <tr> <th>Code number</th> <th>Setting</th> </tr> </thead> <tbody> <tr> <td>0</td> <td>Stop at developer life over</td> </tr> <tr> <td>1</td> <td>Cancel of stop at developer life over * Default</td> </tr> </tbody> </table>	Code number	Setting	0	Stop at developer life over	1	Cancel of stop at developer life over * Default			
Code number	Setting											
0	Stop at developer life over											
1	Cancel of stop at developer life over * Default											
	38	Cancel of stop at drum life over	<p>When this simulation is executed, the current set code number is displayed. Enter the desired code number and press the [START] key to set the code number.</p> <table border="1"> <thead> <tr> <th>Code number</th> <th>Setting</th> </tr> </thead> <tbody> <tr> <td>0</td> <td>Stop at drum life over</td> </tr> <tr> <td>1</td> <td>Cancel of stop at drum life over * Default</td> </tr> </tbody> </table>	Code number	Setting	0	Stop at drum life over	1	Cancel of stop at drum life over * Default			
Code number	Setting											
0	Stop at drum life over											
1	Cancel of stop at drum life over * Default											
	39	Memory capacity check	<p>When this simulation is executed, the current memory capacity is displayed.</p> <table border="1"> <thead> <tr> <th>7-seg display</th> <th>Meaning (Memory capacity)</th> </tr> </thead> <tbody> <tr> <td>16</td> <td>16MByte</td> </tr> <tr> <td>64</td> <td>64MByte</td> </tr> </tbody> </table>	7-seg display	Meaning (Memory capacity)	16	16MByte	64	64MByte			
7-seg display	Meaning (Memory capacity)											
16	16MByte											
64	64MByte											
	42	Transfer ON/OFF timing control setting	<p>When this simulation is executed, the current setting value of transfer ON timing is displayed. Enter a set value and press the [START] key to set the entered value, and the machine will go into the sub code input standby mode. When the [AUTO/TEXT/PHOTO] key is pressed, the ON timing setting and the OFF timing setting are alternatively selected. At that time, the setting is saved and written into the EEPROM.</p> <table border="1"> <thead> <tr> <th>LED</th> <th>Setting mode</th> <th>Default</th> </tr> </thead> <tbody> <tr> <td>AUTO indicator</td> <td>Transfer ON timing</td> <td>34</td> </tr> <tr> <td>TEXT indicator</td> <td>Transfer OFF timing</td> <td>50</td> </tr> </tbody> </table> <p>•Setting range: 1 ~ 99 When the setting value is increased by 1, time is increased by 2ms. •The default, 38, of transfer ON timing means "320ms passed from PS release." The default, 50, of transfer OFF timing means "304ms passed from P-IN OFF."</p>	LED	Setting mode	Default	AUTO indicator	Transfer ON timing	34	TEXT indicator	Transfer OFF timing	50
LED	Setting mode	Default										
AUTO indicator	Transfer ON timing	34										
TEXT indicator	Transfer OFF timing	50										

Main code	Sub code	Contents	Details of operation																											
26	43	Side void amount setting	<p>Used to set the side void amount on the both sides.</p> <p>Enter a set value with the Numeric keys and press the [START] key, and the entered value will be saved and the machine will go into the sub code input standby mode.</p> <p>The setting range is 0 ~ 10. When the set value is increased by 1, the void amount is increased by 0.5mm. The default is 5 (= 2.5mm).</p> <p>To select the setting mode, press the [AUTO/TEXT/PHOTO] key. The set value of the selected mode is displayed on the copy quantity display. At that time, the set value is also saved.</p> <table border="1"> <thead> <tr> <th>LED</th> <th>Setting mode</th> </tr> </thead> <tbody> <tr> <td>AUTO indicator</td> <td>Side void amount (Right)</td> </tr> <tr> <td>TEXT indicator</td> <td>Side void amount (Left)</td> </tr> </tbody> </table> <p>* When the setting value is increased by 1, time is increased by 0.5ms.</p>	LED	Setting mode	AUTO indicator	Side void amount (Right)	TEXT indicator	Side void amount (Left)																					
LED	Setting mode																													
AUTO indicator	Side void amount (Right)																													
TEXT indicator	Side void amount (Left)																													
51		Copy temporary stop function setting	<p>When any key is pressed, it is displayed on the display section. When the [START] key is pressed, the set code data is acquired and stored to the setting variable of sort/group copy temporary stop function and to the EEPROM. The machine goes into the sub code input standby mode.</p> <table border="1"> <thead> <tr> <th>Code number</th> <th>Setting</th> </tr> </thead> <tbody> <tr> <td>0</td> <td>Not stop</td> </tr> <tr> <td>1</td> <td>Stop * Default</td> </tr> </tbody> </table> <p>When the [Interrupt] key is pressed at that time, the machine goes into the sub code input standby mode without rewriting the data. When the [CA] key is pressed, the simulation mode is terminated without rewriting the data.</p> <p>* When this is set to "Stop," temporary stop is made for every 250 copies in one copy job.</p>	Code number	Setting	0	Not stop	1	Stop * Default																					
Code number	Setting																													
0	Not stop																													
1	Stop * Default																													
54		Life correction ON/OFF setting	<p>Setting is made whether the image correction is made according to developer consumption degree (life progress) or not.</p> <p>When this simulation is executed, the current code number is displayed on the 7-seg display. (1=ON [Correction is performed.], 0=OFF [Correction is not performed.])</p> <p>Enter the code number and press [START] key, and the setting is settled and written into the EEPROM and the machine goes into the sub code input standby mode.</p> <p>Switching can be made with [AUTO/TEXT/PHOTO] key, and the set value of the selected mode is displayed on the copy quantity display section.</p> <p>The setting entered at that time is written into the EEPROM.</p> <table border="1"> <thead> <tr> <th>LED</th> <th>Setting mode</th> <th>Default</th> </tr> </thead> <tbody> <tr> <td>All OFF</td> <td>Correction in the AUTO mode (Only for the machine for JAPAN)</td> <td>1</td> </tr> <tr> <td>AUTO indicator</td> <td>Correction in the AUTO mode (Only for the machine for EX JAPAN)</td> <td>1</td> </tr> <tr> <td>TEXT indicator</td> <td>Correction in the TEXT mode</td> <td>1</td> </tr> <tr> <td>PHOTO indicator</td> <td>Correction in the PHOTO mode (Error diffusion)</td> <td>1</td> </tr> <tr> <td>AUTO indicator &amp; TEXT indicator</td> <td>Correction in the AUTO mode with the toner save mode ON</td> <td>1</td> </tr> <tr> <td>AUTO indicator &amp; PHOTO indicator</td> <td>Correction in the AUTO mode with the toner save mode ON</td> <td>1</td> </tr> <tr> <td>TEXT indicator &amp; PHOTO indicator</td> <td>Correction in the TEXT mode with the toner save mode ON</td> <td>1</td> </tr> <tr> <td>AUTO &amp; TEXT &amp; PHOTO indicators</td> <td>Correction in the PHOTO mode (Dither)</td> <td>1</td> </tr> </tbody> </table>	LED	Setting mode	Default	All OFF	Correction in the AUTO mode (Only for the machine for JAPAN)	1	AUTO indicator	Correction in the AUTO mode (Only for the machine for EX JAPAN)	1	TEXT indicator	Correction in the TEXT mode	1	PHOTO indicator	Correction in the PHOTO mode (Error diffusion)	1	AUTO indicator & TEXT indicator	Correction in the AUTO mode with the toner save mode ON	1	AUTO indicator & PHOTO indicator	Correction in the AUTO mode with the toner save mode ON	1	TEXT indicator & PHOTO indicator	Correction in the TEXT mode with the toner save mode ON	1	AUTO & TEXT & PHOTO indicators	Correction in the PHOTO mode (Dither)	1
LED	Setting mode	Default																												
All OFF	Correction in the AUTO mode (Only for the machine for JAPAN)	1																												
AUTO indicator	Correction in the AUTO mode (Only for the machine for EX JAPAN)	1																												
TEXT indicator	Correction in the TEXT mode	1																												
PHOTO indicator	Correction in the PHOTO mode (Error diffusion)	1																												
AUTO indicator & TEXT indicator	Correction in the AUTO mode with the toner save mode ON	1																												
AUTO indicator & PHOTO indicator	Correction in the AUTO mode with the toner save mode ON	1																												
TEXT indicator & PHOTO indicator	Correction in the TEXT mode with the toner save mode ON	1																												
AUTO & TEXT & PHOTO indicators	Correction in the PHOTO mode (Dither)	1																												
69		Used to set the operating for toner end	<p>This simulation used to set the operating conditions for toner end.</p> <p>When this simulation is performed, the current code number is displayed.</p> <p>Enter a code number and press [START] key to save the setting.</p> <p>*Immediately after occurrence of toner end, copying is stopped regardless of the set value.</p> <p>When the cover is opened and closed and the power is turned OFF/ON to initialize the machine, the following operations are performed.</p> <p>&lt;&lt;Operations at toner end &gt;&gt;</p> <table border="1"> <thead> <tr> <th rowspan="2">Code number</th> <th colspan="2">Operations when toner end is detected</th> </tr> <tr> <th>Setting</th> <th>Toner cartridge replacement required indicator</th> </tr> </thead> <tbody> <tr> <td>0</td> <td>Operation enable in toner end</td> <td>Flashing</td> </tr> <tr> <td>1</td> <td>Operation stop in toner end</td> <td>Flashing</td> </tr> <tr> <td>2</td> <td>Operation stop in toner end</td> <td>Flashing</td> </tr> </tbody> </table>	Code number	Operations when toner end is detected		Setting	Toner cartridge replacement required indicator	0	Operation enable in toner end	Flashing	1	Operation stop in toner end	Flashing	2	Operation stop in toner end	Flashing													
Code number	Operations when toner end is detected																													
	Setting	Toner cartridge replacement required indicator																												
0	Operation enable in toner end	Flashing																												
1	Operation stop in toner end	Flashing																												
2	Operation stop in toner end	Flashing																												

Main code	Sub code	Contents	Details of operation																												
30	01	Paper sensor status display	<p>The paper sensor status is displayed with the lamps on the operation panel. * When each sensor detects paper, the corresponding lamp turns on.</p> <table border="1"> <thead> <tr> <th>LED</th> <th>Sensor name</th> </tr> </thead> <tbody> <tr> <td>Developer replacement required indicator</td> <td>Paper exit sensor</td> </tr> <tr> <td>Misfeed indicator(Copier)</td> <td>Duplex sensor</td> </tr> <tr> <td>Toner cartridge replacement required indicator</td> <td>Paper entry sensor</td> </tr> <tr> <td>Bypass tray indicator</td> <td>Bypass tray empty sensor</td> </tr> <tr> <td>1st tray indicator</td> <td>1st tray paper empty sensor</td> </tr> <tr> <td>2nd tray indicator</td> <td>2nd tray paper empty sensor</td> </tr> <tr> <td>3rd tray indicator</td> <td>3rd tray paper empty sensor</td> </tr> <tr> <td>4th tray indicator</td> <td>4th tray paper empty sensor</td> </tr> <tr> <td>Misfeed indicator(1st tray)</td> <td>2nd tray paper feed sensor</td> </tr> <tr> <td>Misfeed indicator(2nd tray)</td> <td>3rd tray paper feed sensor</td> </tr> <tr> <td>Paper required indicator</td> <td>4th tray paper feed sensor</td> </tr> </tbody> </table>	LED	Sensor name	Developer replacement required indicator	Paper exit sensor	Misfeed indicator(Copier)	Duplex sensor	Toner cartridge replacement required indicator	Paper entry sensor	Bypass tray indicator	Bypass tray empty sensor	1st tray indicator	1st tray paper empty sensor	2nd tray indicator	2nd tray paper empty sensor	3rd tray indicator	3rd tray paper empty sensor	4th tray indicator	4th tray paper empty sensor	Misfeed indicator(1st tray)	2nd tray paper feed sensor	Misfeed indicator(2nd tray)	3rd tray paper feed sensor	Paper required indicator	4th tray paper feed sensor				
LED	Sensor name																														
Developer replacement required indicator	Paper exit sensor																														
Misfeed indicator(Copier)	Duplex sensor																														
Toner cartridge replacement required indicator	Paper entry sensor																														
Bypass tray indicator	Bypass tray empty sensor																														
1st tray indicator	1st tray paper empty sensor																														
2nd tray indicator	2nd tray paper empty sensor																														
3rd tray indicator	3rd tray paper empty sensor																														
4th tray indicator	4th tray paper empty sensor																														
Misfeed indicator(1st tray)	2nd tray paper feed sensor																														
Misfeed indicator(2nd tray)	3rd tray paper feed sensor																														
Paper required indicator	4th tray paper feed sensor																														
42	01	Developing counter clear	<p>The developer counter data in the EEPROM is cleared and 0 is displayed on the 7-seg display. When the [Interrupt] key is pressed at that time, the machine goes into the sub code input standby mode. When the [CA] key is pressed, the simulation mode is terminated.</p>																												
43	01	Fusing temperature setting (During normal copy)	<p>When the simulation is terminated, the current set value is displayed. When the [%] key is pressed, the setting is changed. When the [START] key is pressed, the set content is written into the EEPROM and the machine goes into the sub code input standby mode.</p> <table border="1"> <thead> <tr> <th></th> <th>SIM choice (exposure mode)</th> <th>Contents</th> <th>Default</th> </tr> </thead> <tbody> <tr> <td>A</td> <td>AE mode lamp</td> <td>Fusing temperature set value when ready standby.</td> <td>170</td> </tr> <tr> <td>C</td> <td>TEXT mode lamp</td> <td>Black and white plain paper fusing temperature set value.</td> <td>18/20cpm model:150 23cpm model:165</td> </tr> <tr> <td>D</td> <td>PHOTO mode lamp</td> <td>Heavy paper fusing temperature set value.</td> <td>180</td> </tr> <tr> <td>E</td> <td>AE+TEXT mode lamp</td> <td>Main motor begins rotation fusing temperature set value.</td> <td>100</td> </tr> <tr> <td>F</td> <td>AE+PHOTO mode lamp</td> <td>Main motor rotation end time set value.</td> <td>0</td> </tr> <tr> <td>G</td> <td>TEXT+PHOTO mode lamp</td> <td>WARM UP completion time.</td> <td>23</td> </tr> </tbody> </table>		SIM choice (exposure mode)	Contents	Default	A	AE mode lamp	Fusing temperature set value when ready standby.	170	C	TEXT mode lamp	Black and white plain paper fusing temperature set value.	18/20cpm model:150 23cpm model:165	D	PHOTO mode lamp	Heavy paper fusing temperature set value.	180	E	AE+TEXT mode lamp	Main motor begins rotation fusing temperature set value.	100	F	AE+PHOTO mode lamp	Main motor rotation end time set value.	0	G	TEXT+PHOTO mode lamp	WARM UP completion time.	23
	SIM choice (exposure mode)	Contents	Default																												
A	AE mode lamp	Fusing temperature set value when ready standby.	170																												
C	TEXT mode lamp	Black and white plain paper fusing temperature set value.	18/20cpm model:150 23cpm model:165																												
D	PHOTO mode lamp	Heavy paper fusing temperature set value.	180																												
E	AE+TEXT mode lamp	Main motor begins rotation fusing temperature set value.	100																												
F	AE+PHOTO mode lamp	Main motor rotation end time set value.	0																												
G	TEXT+PHOTO mode lamp	WARM UP completion time.	23																												
	02	Setting of item related to fusing temperature	<p>When the simulation is terminated, the current set value is displayed. When the [%] key is pressed, the setting is changed. When the [START] key is pressed, the set content is written into the EEPROM and the machine goes into the sub code input standby mode.</p> <table border="1"> <thead> <tr> <th></th> <th>SIM choice (exposure mode)</th> <th>Contents</th> <th>Default</th> </tr> </thead> <tbody> <tr> <td>H</td> <td>AE mode lamp</td> <td>ALARM STOP At shift sub thermister temperature.</td> <td>230</td> </tr> <tr> <td>I</td> <td>TEXT mode lamp</td> <td>ALARM STOP At release sub thermister temperature.</td> <td>180</td> </tr> <tr> <td>J</td> <td>PHOTO mode lamp</td> <td>Rotation time after JOB ends (COOL DOWN)</td> <td>0</td> </tr> </tbody> </table>		SIM choice (exposure mode)	Contents	Default	H	AE mode lamp	ALARM STOP At shift sub thermister temperature.	230	I	TEXT mode lamp	ALARM STOP At release sub thermister temperature.	180	J	PHOTO mode lamp	Rotation time after JOB ends (COOL DOWN)	0												
	SIM choice (exposure mode)	Contents	Default																												
H	AE mode lamp	ALARM STOP At shift sub thermister temperature.	230																												
I	TEXT mode lamp	ALARM STOP At release sub thermister temperature.	180																												
J	PHOTO mode lamp	Rotation time after JOB ends (COOL DOWN)	0																												
	03	Fusing temperature set value in preheating	<p>When the simulation is terminated, the current set value is displayed. When the [%] key is pressed, the setting is changed. When the [START] key is pressed, the set content is written into the EEPROM and the machine goes into the sub code input standby mode.</p> <table border="1"> <thead> <tr> <th></th> <th>SIM choice (exposure mode)</th> <th>Contents</th> <th>Default</th> </tr> </thead> <tbody> <tr> <td>N</td> <td>AE mode lamp</td> <td>Fusing temperature set value when preheating.</td> <td>110</td> </tr> <tr> <td>Q</td> <td>TEXT mode lamp</td> <td>Fusing temperature set value when Warm-UP at 120°C or below.</td> <td>160</td> </tr> <tr> <td>T</td> <td>PHOTO mode lamp</td> <td>Fusing temperature set value when Warm-UP at 120°C or below.</td> <td>150</td> </tr> </tbody> </table>		SIM choice (exposure mode)	Contents	Default	N	AE mode lamp	Fusing temperature set value when preheating.	110	Q	TEXT mode lamp	Fusing temperature set value when Warm-UP at 120°C or below.	160	T	PHOTO mode lamp	Fusing temperature set value when Warm-UP at 120°C or below.	150												
	SIM choice (exposure mode)	Contents	Default																												
N	AE mode lamp	Fusing temperature set value when preheating.	110																												
Q	TEXT mode lamp	Fusing temperature set value when Warm-UP at 120°C or below.	160																												
T	PHOTO mode lamp	Fusing temperature set value when Warm-UP at 120°C or below.	150																												

Main code	Sub code	Contents	Details of operation																												
43	04	Fusing temperature correction setting	<p>When the simulation is terminated, the current set value is displayed. When the [%] key is pressed, the setting is changed. When the [START] key is pressed, the set content is written into the EEPROM and the machine goes into the sub code input standby mode.</p> <table border="1"> <thead> <tr> <th></th> <th>SIM choice (exposure mode)</th> <th>Contents</th> <th>Default</th> </tr> </thead> <tbody> <tr> <td>A</td> <td>AE mode lamp</td> <td>Correction temperature when initial JOB (UP)</td> <td>5</td> </tr> <tr> <td>B</td> <td>TEXT mode lamp</td> <td>Correction temperature when in the latter half JOB (DOWN)</td> <td>-5</td> </tr> <tr> <td>C</td> <td>PHOTO mode lamp</td> <td>The number of sheets of initial temperature correction.</td> <td>3</td> </tr> <tr> <td>D</td> <td>AE+TEXT mode lamp</td> <td>A3/WLT The number of sheets of temperature correction (In the latter half)</td> <td>50</td> </tr> <tr> <td>E</td> <td>AE+PHOTO mode lamp</td> <td>A4/LT The number of sheets of temperature correction (In the latter half)</td> <td>50</td> </tr> <tr> <td>F</td> <td>TEXT+PHOTO mode lamp</td> <td>A3/WLT/A4/LT except The number of sheets of temperature correction (In the latter half)</td> <td>25</td> </tr> </tbody> </table>		SIM choice (exposure mode)	Contents	Default	A	AE mode lamp	Correction temperature when initial JOB (UP)	5	B	TEXT mode lamp	Correction temperature when in the latter half JOB (DOWN)	-5	C	PHOTO mode lamp	The number of sheets of initial temperature correction.	3	D	AE+TEXT mode lamp	A3/WLT The number of sheets of temperature correction (In the latter half)	50	E	AE+PHOTO mode lamp	A4/LT The number of sheets of temperature correction (In the latter half)	50	F	TEXT+PHOTO mode lamp	A3/WLT/A4/LT except The number of sheets of temperature correction (In the latter half)	25
	SIM choice (exposure mode)	Contents	Default																												
A	AE mode lamp	Correction temperature when initial JOB (UP)	5																												
B	TEXT mode lamp	Correction temperature when in the latter half JOB (DOWN)	-5																												
C	PHOTO mode lamp	The number of sheets of initial temperature correction.	3																												
D	AE+TEXT mode lamp	A3/WLT The number of sheets of temperature correction (In the latter half)	50																												
E	AE+PHOTO mode lamp	A4/LT The number of sheets of temperature correction (In the latter half)	50																												
F	TEXT+PHOTO mode lamp	A3/WLT/A4/LT except The number of sheets of temperature correction (In the latter half)	25																												
	10	Postcard paper feed cycle setting	<p>Used to set the paper feed cycle timing in postcard printing. (Pickup interval)[1] ~ [99] (Center [50], Unit: 100msec)(Example: When 50, pickup interval = 100msec x 50) This simulation functions only when the destination is set to Japan AB series.</p>																												
	12	Fusing fan rotating speed setting when ready state	<p>The rotating speed of the fusing fan is set when the thermister of the fusing unit detects 190°C or above or when the thermister of the fusing unit detects 190°C or below. (Only when the machine is in the ready state, the fusing fan rotates at the speed set with this simulation.)</p> <p>When this simulation is executed, the current code number is displayed. When [AUTO/TEXT/PHOTO] key is pressed, the set value for detection of 190°C or above and the set value for detection of 190°C or below are switched alternatively. To change the set value for detection of 190°C or above, enter the code number when the AUTO indicator is lighted. To change the set value for detection of 190°C or below, enter the code number when the TEXT indicator is lighted. When [START] key is pressed after entering the code number, the setting is settled and saved into the EEPROM and the machine goes into the sub code input standby mode.</p> <table border="1"> <thead> <tr> <th>LED</th> <th>Setting mode</th> <th>Code number</th> <th>Setting</th> </tr> </thead> <tbody> <tr> <td rowspan="2">AUTO indicator</td> <td rowspan="2">When 190°C or below is detected</td> <td>0</td> <td>Low speed rotation*Default</td> </tr> <tr> <td>1</td> <td>High speed rotation</td> </tr> <tr> <td rowspan="2">TEXT indicator</td> <td rowspan="2">When 190°C or above is detected</td> <td>0</td> <td>Low speed rotation</td> </tr> <tr> <td>1</td> <td>High speed rotation*Default</td> </tr> </tbody> </table>	LED	Setting mode	Code number	Setting	AUTO indicator	When 190°C or below is detected	0	Low speed rotation*Default	1	High speed rotation	TEXT indicator	When 190°C or above is detected	0	Low speed rotation	1	High speed rotation*Default												
LED	Setting mode	Code number	Setting																												
AUTO indicator	When 190°C or below is detected	0	Low speed rotation*Default																												
		1	High speed rotation																												
TEXT indicator	When 190°C or above is detected	0	Low speed rotation																												
		1	High speed rotation*Default																												
	13	Fusing paper interval control allow/inhibit setting	<p>Used to set the paper feed timing of 21st and later page to A3 or WLT when multi copying or printing paper of narrow width. (A3 or WLT depends on the destination.) When this simulation is executed, the currently set code number is displayed. Enter a desired code number and press the [START] key, and the entered code number is written into the EEPROM and the machine goes into the sub code entry standby mode.</p> <table border="1"> <thead> <tr> <th>Code number</th> <th>Setting</th> </tr> </thead> <tbody> <tr> <td>0</td> <td>Inhibit * Default</td> </tr> <tr> <td>1</td> <td>Allow</td> </tr> </tbody> </table> <p><b>&lt;Applicable paper&gt;</b>  1) Paper tray: A4R, B5R, 8-1/2" X 14", 8-1/2" X 13", 8-1/2" X 11", A5, INV  2) Bypass tray: A4R, B5R, 8-1/2" X 14", 8-1/2" X 13", 8-1/2" X 11", A5, INV,16KR  * A5 size for bypass tray is valid only for EX Japan AB series.</p>	Code number	Setting	0	Inhibit * Default	1	Allow																						
Code number	Setting																														
0	Inhibit * Default																														
1	Allow																														

Main code	Sub code	Contents	Details of operation																		
44	01	Toner density control Enable/Disable (ON/OFF) setting	<p>Setting is made whether the toner density control is performed or not. When this simulation is executed, the current code number is displayed on the 7-seg display. (1=ON [Enable], 0=OFF [Disable]) Enter a code number and press [START] key, and the setting is settled and saved into the EEPROM and the machine goes into the sub code input standby mode.</p> <p>Switching can be made with [AUTO/TEXT/PHOTO] key, and the set value of the selected mode is displayed on the copy quantity display section. The entered value at that time is written into the EEPROM.</p> <table border="1"> <thead> <tr> <th>LED</th> <th>Setting mode</th> <th>Default</th> </tr> </thead> <tbody> <tr> <td>AUTO indicator</td> <td>Print ration correction</td> <td>1</td> </tr> <tr> <td>TEXT indicator</td> <td>Life correction</td> <td>18/20cpm machine: 0 23cpm machine:1</td> </tr> <tr> <td>AUTO indicator &amp; PHOTO indicator</td> <td>Drip infusion ★</td> <td>0</td> </tr> <tr> <td>TEXT indicator &amp; PHOTO indicator</td> <td>Purge process ★</td> <td>0</td> </tr> <tr> <td>AUTO indicator &amp; TEXT indicator &amp; PHOTO indicator</td> <td>Unconditional toner supply</td> <td>1</td> </tr> </tbody> </table> <p><b>&lt;Descriptions on each correction&gt;</b>  <b>Print ratio correction</b>  In this correction, the toner supply interval is determined according to the print ratio, and an overtoner is prevented.</p> <p><b>Life correction</b>  When the life of any consumable part approached the end, this correction prevents against undertoner.</p> <p><b>Note for items marked with ★</b>  Drip infusion and Purge process are simulations for analysis, and do not set them to "Enable=1" in the market.  If these items are set to "Enable=1", the toner density rises or falls extremely, resulting in developer fall and toner dispersion.  If they are set to "Enable=1", developer must be replaced and the machine inside and the process unit must be cleaned.</p> <p><b>Unconditional toner supply</b>  When the DV unit and the drum unit run idle, a small quantity of toner is consumed. To supply this consumption, toner is supplied according to the rotation time of the DV unit.</p>	LED	Setting mode	Default	AUTO indicator	Print ration correction	1	TEXT indicator	Life correction	18/20cpm machine: 0 23cpm machine:1	AUTO indicator & PHOTO indicator	Drip infusion ★	0	TEXT indicator & PHOTO indicator	Purge process ★	0	AUTO indicator & TEXT indicator & PHOTO indicator	Unconditional toner supply	1
LED	Setting mode	Default																			
AUTO indicator	Print ration correction	1																			
TEXT indicator	Life correction	18/20cpm machine: 0 23cpm machine:1																			
AUTO indicator & PHOTO indicator	Drip infusion ★	0																			
TEXT indicator & PHOTO indicator	Purge process ★	0																			
AUTO indicator & TEXT indicator & PHOTO indicator	Unconditional toner supply	1																			
16		Toner density control data check and toner density control correction amount display	<p>The output value of the ATC sensor is checked and the toner density control correction value is displayed on the 7-seg display. The display mode can be switched by pressing [AUTO/TEXT/PHOTO] key. When [Interrupt] key is pressed, the machine goes into the sub code input standby mode. When [CA] key is pressed, the machine goes out of the simulation mode.</p> <table border="1"> <thead> <tr> <th>LED</th> <th>Display content</th> </tr> </thead> <tbody> <tr> <td>AUTO indicator</td> <td>The current output value of the ATC sensor is displayed.</td> </tr> <tr> <td>TEXT indicator</td> <td>The correction value according to the progress of life is added to the current output value of the ATC sensor and the sum is displayed.</td> </tr> </tbody> </table>	LED	Display content	AUTO indicator	The current output value of the ATC sensor is displayed.	TEXT indicator	The correction value according to the progress of life is added to the current output value of the ATC sensor and the sum is displayed.												
LED	Display content																				
AUTO indicator	The current output value of the ATC sensor is displayed.																				
TEXT indicator	The correction value according to the progress of life is added to the current output value of the ATC sensor and the sum is displayed.																				
34		Transfer current setting	<p>Used to set the transfer current for the front surface and that for the back surface. When this simulation is executed, the current set value is displayed on the 7-seg display. Select the set value with the zoom [Zoom] keys and press the [START] key, and the set content is written into the EEPROM and the machine goes into the sub code input standby mode. Press the [AUTO/TEXT/PHOTO] key to select each setting mode. At that time, the setup content is written into the EEPROM. The set range is 90uA ~ 360uA in the increment of 10uA.</p> <table border="1"> <thead> <tr> <th>LED</th> <th>Setting mode</th> </tr> </thead> <tbody> <tr> <td>AUTO indicator</td> <td>Normal size width: Front</td> </tr> <tr> <td>TEXT indicator</td> <td>Normal size width: Back(Duplex model only)</td> </tr> <tr> <td>AUTO indicator &amp; PHOTO indicator</td> <td>Small size width: Front</td> </tr> <tr> <td>TEXT indicator &amp; PHOTO indicator</td> <td>Small size width: Back(Duplex model only)</td> </tr> <tr> <td>AUTO &amp; TEXT &amp; PHOTO indicator</td> <td>Bypass tray</td> </tr> </tbody> </table> <p>* Small size paper must be Letter R (A4R) or smaller.  * For the special size of tray, use the normal size width.</p>	LED	Setting mode	AUTO indicator	Normal size width: Front	TEXT indicator	Normal size width: Back(Duplex model only)	AUTO indicator & PHOTO indicator	Small size width: Front	TEXT indicator & PHOTO indicator	Small size width: Back(Duplex model only)	AUTO & TEXT & PHOTO indicator	Bypass tray						
LED	Setting mode																				
AUTO indicator	Normal size width: Front																				
TEXT indicator	Normal size width: Back(Duplex model only)																				
AUTO indicator & PHOTO indicator	Small size width: Front																				
TEXT indicator & PHOTO indicator	Small size width: Back(Duplex model only)																				
AUTO & TEXT & PHOTO indicator	Bypass tray																				

Main code	Sub code	Contents	Details of operation														
46	02	Copy density adjustment (600dpi)	<p>Used to set the copy density for each mode.</p> <p><b>(Operating procedure)</b>            When this simulation is executed, warm-up and shading are operated, and the current set value is displayed in two digits. (Default [50])Change the set value and press the [START] key, and a copy is made according to the set value. The greater the set value is, the darker the density is, and vice versa. In this case, only a copy at Exp. 3 can be made.            When, however, the density is set darker, Exp.1 and Exp. 5 become darker, too.            If the density is set lighter, Exp. 1 and Exp. 5 become lighter, too.            To select a desired copy mode, press the [AUTO/TEXT/PHOTO] key.            The selected copy mode set value is displayed on the copy quantity display.            (Adjustment range: 1 ~ 99)</p> <table border="1"> <thead> <tr> <th>LED</th> <th>Copy mode</th> </tr> </thead> <tbody> <tr> <td>AUTO indicator</td> <td>AUTO exposure mode (600dpi)</td> </tr> <tr> <td>TEXT indicator</td> <td>TEXT mode (600dpi)</td> </tr> <tr> <td>PHOTO indicator</td> <td>PHOTO mode (Error diffusion)</td> </tr> <tr> <td>AUTO indicator &amp; PHOTO indicator</td> <td>TS mode (AUTO exposure) (600dpi)</td> </tr> <tr> <td>TEXT indicator &amp; PHOTO indicator</td> <td>TS mode (TEXT) (600dpi)</td> </tr> <tr> <td>AUTO indicator &amp; TEXT indicator &amp; PHOTO indicator</td> <td>PHOTO mode(Dither)</td> </tr> </tbody> </table>	LED	Copy mode	AUTO indicator	AUTO exposure mode (600dpi)	TEXT indicator	TEXT mode (600dpi)	PHOTO indicator	PHOTO mode (Error diffusion)	AUTO indicator & PHOTO indicator	TS mode (AUTO exposure) (600dpi)	TEXT indicator & PHOTO indicator	TS mode (TEXT) (600dpi)	AUTO indicator & TEXT indicator & PHOTO indicator	PHOTO mode(Dither)
LED	Copy mode																
AUTO indicator	AUTO exposure mode (600dpi)																
TEXT indicator	TEXT mode (600dpi)																
PHOTO indicator	PHOTO mode (Error diffusion)																
AUTO indicator & PHOTO indicator	TS mode (AUTO exposure) (600dpi)																
TEXT indicator & PHOTO indicator	TS mode (TEXT) (600dpi)																
AUTO indicator & TEXT indicator & PHOTO indicator	PHOTO mode(Dither)																
	10	Copy exposure level adjustment, individual setting (Text) 600dpi	<p>Used to adjust the shift amount and the inclination value for each density level (1 ~ 5) when the exposure mode is the TEXT mode (including TS)</p> <ul style="list-style-type: none"> <li>•The shift amount is the same as the gamma (gradation), and is used to set the overall brightness.            When the shift amount is increased, the overall brightness is decreased.            When the shift amount is decreased, the overall brightness is increased</li> <li>•The inclination value changes the gamma (gradation).            When the set value is increased, the gamma is increased to increase the contrast.            (Clearer black and white images)            When the set value is decreased, the gamma is decreased to decrease the contrast.            (Increased gradation)</li> </ul> <p>* Press the [%] key to switch between the shift amount and the inclination value.            The 7-seg display shows the mode.            The initial display is "Shift".            Shift is indicated as "b" (Brightness).            Inclination is indicated as "c" (Contrast).</p> <p><b>(Example)</b>            [b50] → [%] key → [c50] → [%] key → [b50] → [%] key → [c50] → ...</p> <p>* Select the adjustment level with the [Light and Dark] keys.            The AUTO/TEXT/PHOTO indicators displays the selected level (Exp. 1 ~ Exp. 5)            * Select TEXT or TEXT (TS) with the [AUTO/TEXT/PHOTO] key.</p> <table border="1"> <thead> <tr> <th>LED</th> <th>Exposure mode to be adjusted</th> </tr> </thead> <tbody> <tr> <td>TEXT indicators</td> <td>TEXT mode</td> </tr> <tr> <td>TEXT indicator &amp; PHOTO indicator</td> <td>TEXT (TS) mode</td> </tr> </tbody> </table> <p>* Change the shift amount and the inclination value with the Numeric keys.            The set range is [1] ~ [99]. The default is [50].            Change the set value and press the [START] key, and a copy is made at the set value.</p>	LED	Exposure mode to be adjusted	TEXT indicators	TEXT mode	TEXT indicator & PHOTO indicator	TEXT (TS) mode								
LED	Exposure mode to be adjusted																
TEXT indicators	TEXT mode																
TEXT indicator & PHOTO indicator	TEXT (TS) mode																

Main code	Sub code	Contents	Details of operation																		
46	11	Copy exposure level adjustment, individual setting (Photo) 600dpi	<p>Used to adjust the shift amount and the inclination value for each density level (1 ~ 5) when the exposure mode is the PHOTO mode</p> <ul style="list-style-type: none"> <li>•The shift amount is the same as the gamma (gradation), and is used to set the overall brightness. When the shift amount is increased, the overall brightness is decreased. When the shift amount is decreased, the overall brightness is increased</li> <li>•The inclination value changes the gamma (gradation). When the set value is increased, the gamma is increased to increase the contrast. (Clearer black and white images) When the set value is decreased, the gamma is decreased to decrease the contrast. (Increased gradation)</li> </ul> <p>* Press the [%] key to switch between the shift amount and the inclination value.</p> <p>The 7-seg display shows the mode. The initial display is "Shift." Shift is indicated as "b" (Brightness). Inclination is indicated as "c" (Contrast).</p> <p><b>(Example)</b> [b50] → [%] key → [c50] → [%] key → [b50] → [%] key → [c50] → ...</p> <p>* Select the adjustment level with the [Light and Dark] keys.</p> <p>The AUTO/TEXT/PHOTO indicators displays the selected level (Exp. 1 ~ Exp. 5)</p> <p>* Select PHOTO(Error diffusion) or PHOTO(Dither) with the [AUTO/TEXT/PHOTO] key</p> <table border="1"> <thead> <tr> <th>LED</th> <th>Exposure mode to be adjusted</th> </tr> </thead> <tbody> <tr> <td>PHOTO indicator</td> <td>PHOTO mode (Error diffusion)</td> </tr> <tr> <td>TEXT indicator &amp; PHOTO indicator</td> <td>PHOTO mode (Dither)</td> </tr> </tbody> </table> <p>* Change the shift amount and the inclination value with the Numeric keys. The set range is [1] ~ [99]. The default is [50]. Change the set value and press the [START] key, and a copy is made at the set value.</p>	LED	Exposure mode to be adjusted	PHOTO indicator	PHOTO mode (Error diffusion)	TEXT indicator & PHOTO indicator	PHOTO mode (Dither)												
LED	Exposure mode to be adjusted																				
PHOTO indicator	PHOTO mode (Error diffusion)																				
TEXT indicator & PHOTO indicator	PHOTO mode (Dither)																				
19		Exposure mode setting (Gamma table setting / AUTO exposure operation mode setting / PHOTO image process setting)	<p>Used set for the following three exposure modes. Enter a code number and press the [START] key, and the entered number is written into the EEPROM and the machine goes into the sub code entry standby mode. (When the [AUTO/TEXT/PHOTO] key is pressed, the number is written into the EEPROM and the set item is changed.)</p> <p><b>&lt;&lt;Gamma table setting&gt;&gt;</b> When this simulation is executed, the current set code number of gamma table is displayed.</p> <p>* When setting the gamma table, no AUTO/TEXT/PHOTO indicators are lighted.</p> <table border="1"> <thead> <tr> <th>Code number</th> <th>Setting (Gamma table)</th> </tr> </thead> <tbody> <tr> <td>1</td> <td>Image quality priority mode</td> </tr> <tr> <td>2</td> <td>Toner consumption priority mode * Default</td> </tr> </tbody> </table> <p>* If this setting is changed, the set content of SIM46-30 is reset to the default.</p> <p><b>&lt;&lt;AUTO exposure mode&gt;&gt;</b> When the [AUTO/TEXT/PHOTO] key is pressed in gamma table setting, the mode is changed to the AUTO exposure operation mode setting and the current set code number of the AUTO exposure operation mode is displayed. (Default: 0)</p> <p>* When setting the AUTO exposure operation mode, the AUTO indicator is lighted.</p> <table border="1"> <thead> <tr> <th>Code number</th> <th>Setting (AUTO exposure operation mode)</th> </tr> </thead> <tbody> <tr> <td>0</td> <td>Lead edge stop * Default</td> </tr> <tr> <td>1</td> <td>Rear time process</td> </tr> </tbody> </table> <p><b>&lt;Photo image process setting&gt;</b> When the [AUTO/TEXT/PHOTO] key is pressed during the AUTO exposure operation mode setting, the setting mode is changed to the photo image process setting and the currently set code number of the photo image process setting is displayed.</p> <p>* When in the photo image process setting, the [Photo mode lamp] is lighted.</p> <table border="1"> <thead> <tr> <th>Code number</th> <th>Setting (Photo image process setting)</th> </tr> </thead> <tbody> <tr> <td>1</td> <td>Error diffusion process</td> </tr> <tr> <td>2</td> <td>Dither process * Default</td> </tr> </tbody> </table>	Code number	Setting (Gamma table)	1	Image quality priority mode	2	Toner consumption priority mode * Default	Code number	Setting (AUTO exposure operation mode)	0	Lead edge stop * Default	1	Rear time process	Code number	Setting (Photo image process setting)	1	Error diffusion process	2	Dither process * Default
Code number	Setting (Gamma table)																				
1	Image quality priority mode																				
2	Toner consumption priority mode * Default																				
Code number	Setting (AUTO exposure operation mode)																				
0	Lead edge stop * Default																				
1	Rear time process																				
Code number	Setting (Photo image process setting)																				
1	Error diffusion process																				
2	Dither process * Default																				

Main code	Sub code	Contents	Details of operation																						
46	20	SPF exposure correction (Only when the RSPF is installed)	<p>Used to adjust the exposure correction amount in the SPF mode (for the OC mode).</p> <p><b>(Operating procedure)</b>            When this simulation is executed, the current set value is displayed.            Enter the adjustment value with the Numeric keys and press the [START] key.            The entered set value is stored and a copy is made.            When the [Interrupt] key is pressed, the entered value is saved and the machine goes into the sub code entry standby mode. When the [CA] key is pressed, the entered value is saved and the simulation is terminated. [1] ~ [99] (Center [50])</p> <p>* The greater the set value is, the darker the density is. The smaller the set value is, the lighter the density is.            * The exposure mode is TEXT fixed. The LED does not change, either.            The exposure level can not be adjusted.</p>																						
	29	Image contrast adjustment (600dpi)	<p>Used to adjust the contrast for each mode.</p> <p><b>(Operating procedure)</b>            When this simulation is executed, warm-up and shading are performed, and the current set value is displayed in two digits. (Default: 50)            The AUTO/TEXT/PHOTO indicators is lighted.            Change the set value and press the [START] key, and a copy is made according to the set value.            The greater the set value is, the higher the contrast is.            The smaller the set value is, the lower the contrast is.            In this case, only a copy at Exp. 3 is made.            However, the contrasts at Exp.1 and Exp. 5 are also changed accordingly.            To select a desired copy mode, press the [AUTO/TEXT/PHOTO] key.            The selected copy mode set value is displayed on the copy quantity display.            (Adjustment range: 1 ~ 99)</p> <table border="1"> <thead> <tr> <th>LED</th> <th>Copy mode</th> </tr> </thead> <tbody> <tr> <td>AUTO indicator</td> <td>AUTO exposure mode (600dpi)</td> </tr> <tr> <td>TEXT indicator</td> <td>TEXT mode (600dpi)</td> </tr> <tr> <td>PHOTO indicator</td> <td>PHOTO mode (Error diffusion)</td> </tr> <tr> <td>AUTO indicator &amp; PHOTO indicator</td> <td>TS mode (AUTO exposure) (600dpi)</td> </tr> <tr> <td>TEXT indicator &amp; PHOTO indicator</td> <td>TS mode (TEXT) (600dpi)</td> </tr> <tr> <td>AUTO indicator &amp; TEXT indicator &amp; PHOTO indicator</td> <td>PHOTO mode(Dither)</td> </tr> </tbody> </table>	LED	Copy mode	AUTO indicator	AUTO exposure mode (600dpi)	TEXT indicator	TEXT mode (600dpi)	PHOTO indicator	PHOTO mode (Error diffusion)	AUTO indicator & PHOTO indicator	TS mode (AUTO exposure) (600dpi)	TEXT indicator & PHOTO indicator	TS mode (TEXT) (600dpi)	AUTO indicator & TEXT indicator & PHOTO indicator	PHOTO mode(Dither)								
LED	Copy mode																								
AUTO indicator	AUTO exposure mode (600dpi)																								
TEXT indicator	TEXT mode (600dpi)																								
PHOTO indicator	PHOTO mode (Error diffusion)																								
AUTO indicator & PHOTO indicator	TS mode (AUTO exposure) (600dpi)																								
TEXT indicator & PHOTO indicator	TS mode (TEXT) (600dpi)																								
AUTO indicator & TEXT indicator & PHOTO indicator	PHOTO mode(Dither)																								
	30	AUTO exposure limit setting	<p>Used to set the AUTO exposure and the limit value at AUTO exposure (toner save).The set range is 0 ~ 255. The default is 196.</p> <p>Change the setting and press the [START] key, and it will be written into the EEPROM and the machine will go into the sub code input standby mode. When the [AUTO/TEXT/PHOTO] key is pressed, the machine goes back to the gamma table setting mode.</p> <table border="1"> <thead> <tr> <th>LED</th> <th>Setting mode</th> </tr> </thead> <tbody> <tr> <td>AUTO indicator</td> <td>Limit value for OC scan AUTO exposure</td> </tr> <tr> <td>TEXT indicator</td> <td>Limit value for OC scan AUTO exposure (toner save)</td> </tr> <tr> <td>PHOTO indicator</td> <td>Limit value for SPF scan AUTO exposure</td> </tr> <tr> <td>AUTO indicator &amp; PHOTO indicator</td> <td>Limit value for SPF scan AUTO exposure (toner save)</td> </tr> </tbody> </table> <p><b>&lt;Remark&gt;</b>            When SIM26-60 (Destination setting) and SIM46-19 (Auto exposure mode) are changed, this set content of this simulation is also changed to the default.</p>	LED	Setting mode	AUTO indicator	Limit value for OC scan AUTO exposure	TEXT indicator	Limit value for OC scan AUTO exposure (toner save)	PHOTO indicator	Limit value for SPF scan AUTO exposure	AUTO indicator & PHOTO indicator	Limit value for SPF scan AUTO exposure (toner save)												
LED	Setting mode																								
AUTO indicator	Limit value for OC scan AUTO exposure																								
TEXT indicator	Limit value for OC scan AUTO exposure (toner save)																								
PHOTO indicator	Limit value for SPF scan AUTO exposure																								
AUTO indicator & PHOTO indicator	Limit value for SPF scan AUTO exposure (toner save)																								
	31	Image sharpness adjustment	<p>Used to adjust clear/shading of image for each mode.</p> <p><b>(Operating procedure)</b>            When this simulation is executed, warm-up and shading are performed, and the current set value is displayed in two digits. (Default: 1)            Change the set value and press the [START] key, and a copy is made according to the set value.</p> <table border="1"> <thead> <tr> <th>Set value</th> <th>Image quality</th> </tr> </thead> <tbody> <tr> <td>0</td> <td>Shading</td> </tr> <tr> <td>1</td> <td>Standard *Default</td> </tr> <tr> <td>2</td> <td>Clear</td> </tr> </tbody> </table> <p>Use the [AUTO/TEXT/PHOTO] key to select each copy mode. The code number of the selected copy mode is displayed on the copy quantity display.</p> <table border="1"> <thead> <tr> <th>LED</th> <th>Copy mode</th> </tr> </thead> <tbody> <tr> <td>AUTO indicator</td> <td>AUTO exposure mode</td> </tr> <tr> <td>TEXT indicator</td> <td>TEXT mode</td> </tr> <tr> <td>PHOTO indicator</td> <td>PHOTO mode (Error diffusion)</td> </tr> <tr> <td>AUTO indicator &amp; PHOTO indicator</td> <td>TS mode (AUTO exposureE)</td> </tr> <tr> <td>TEXT indicator &amp; PHOTO indicator</td> <td>TS mode (TEXT)</td> </tr> <tr> <td>AUTO indicator &amp; TEXT indicator &amp; PHOTO indicator</td> <td>PHOTO mode(Dither)</td> </tr> </tbody> </table>	Set value	Image quality	0	Shading	1	Standard *Default	2	Clear	LED	Copy mode	AUTO indicator	AUTO exposure mode	TEXT indicator	TEXT mode	PHOTO indicator	PHOTO mode (Error diffusion)	AUTO indicator & PHOTO indicator	TS mode (AUTO exposureE)	TEXT indicator & PHOTO indicator	TS mode (TEXT)	AUTO indicator & TEXT indicator & PHOTO indicator	PHOTO mode(Dither)
Set value	Image quality																								
0	Shading																								
1	Standard *Default																								
2	Clear																								
LED	Copy mode																								
AUTO indicator	AUTO exposure mode																								
TEXT indicator	TEXT mode																								
PHOTO indicator	PHOTO mode (Error diffusion)																								
AUTO indicator & PHOTO indicator	TS mode (AUTO exposureE)																								
TEXT indicator & PHOTO indicator	TS mode (TEXT)																								
AUTO indicator & TEXT indicator & PHOTO indicator	PHOTO mode(Dither)																								

Main code	Sub code	Contents	Details of operation																																														
48	01	Main scanning/sub scanning direction magnification ratio adjustment	<p>Used to adjust the magnification ratio in the main scanning direction (front/rear) and the sub scanning direction. Enter the adjustment value with the Numeric keys and press the [START] key, and the entered value is saved a copy is made. (When the set value is increased by 1, the magnification ratio is increased by 0.1 %.) (Adjustment range: 1 ~ 99, Default: 50)</p> <table border="1"> <thead> <tr> <th>LED</th> <th>Adjustment mode</th> </tr> </thead> <tbody> <tr> <td>TEXT indicator</td> <td>Main scanning direction magnification ratio adjustment</td> </tr> <tr> <td>PHOTO indicator</td> <td>Sub scanning direction magnification ratio adjustment</td> </tr> </tbody> </table>	LED	Adjustment mode	TEXT indicator	Main scanning direction magnification ratio adjustment	PHOTO indicator	Sub scanning direction magnification ratio adjustment																																								
LED	Adjustment mode																																																
TEXT indicator	Main scanning direction magnification ratio adjustment																																																
PHOTO indicator	Sub scanning direction magnification ratio adjustment																																																
	05	RSPF mode sub scanning magnification ratio adjustment in copying (Only when the RSPF is installed)	<p>The current RSPF mode sub scan direction magnification ratio adjustment value is displayed. When the [START] key is pressed, the entered value is acquired and saved into the EEPROM, and a copy is made. When the [CA] key is pressed, the simulation mode is terminated. In RSPF adjustment, after the machine enters the copy mode of one page, select the single copy mode with the [ORIGINAL TO COPY] key to shift to the single copy mode, making two pages of single copy. For printing, regardless of the AUTO/TEXT/PHOTO indicators and Light and Dark indicators display, the density mode = MANUAL, and density level = 3. (Adjustment range: 1 ~ 99, Default: 50)</p> <table border="1"> <thead> <tr> <th>LED</th> <th>Adjustment mode</th> </tr> </thead> <tbody> <tr> <td>AUTO indicator</td> <td>RSPF document surface magnification ratio adjustment</td> </tr> <tr> <td>TEXT indicator</td> <td>RSPF document back magnification ratio adjustment</td> </tr> </tbody> </table>	LED	Adjustment mode	AUTO indicator	RSPF document surface magnification ratio adjustment	TEXT indicator	RSPF document back magnification ratio adjustment																																								
LED	Adjustment mode																																																
AUTO indicator	RSPF document surface magnification ratio adjustment																																																
TEXT indicator	RSPF document back magnification ratio adjustment																																																
49	01	Flash ROM program writing mode	<p><b>(Operating procedure)</b> When this simulation is executed, "d" is displayed on the copy quantity display and the machine enters the Flash ROM program writing mode. Use the writing tool on the PC to write the program. During writing, the display is made as follows. After completion of downloading, turn OFF/ON the power to reset.</p> <table border="1"> <thead> <tr> <th>Status</th> <th>7-seg display</th> <th>POWER SAVE indicator</th> <th>DUAL PAGE COPY indicator</th> </tr> </thead> <tbody> <tr> <td>Download data reception</td> <td>d</td> <td>ON</td> <td>OFF</td> </tr> <tr> <td>Data delete start</td> <td>d</td> <td>OFF</td> <td>ON</td> </tr> <tr> <td>Data write (Boot section)</td> <td>d</td> <td>Flash</td> <td>OFF</td> </tr> <tr> <td>Data write (Program section)</td> <td>d</td> <td>Flash</td> <td>Flash</td> </tr> <tr> <td>Sum check</td> <td>d</td> <td>ON</td> <td>ON</td> </tr> <tr> <td>Download end</td> <td>OFF</td> <td>OFF</td> <td>OFF</td> </tr> <tr> <td>Error status</td> <td>E*</td> <td>OFF</td> <td>OFF</td> </tr> </tbody> </table> <p>NOTE [*] in the error status indicates as follows to show the error position.</p> <table border="1"> <tbody> <tr> <td>00 Data receive error</td> <td>08 Sum check error (EEPROM section)</td> </tr> <tr> <td>02 FLASH ROM delete error</td> <td>09 EEPROM write error</td> </tr> <tr> <td>03 FLASH ROM write error (Boot section)</td> <td>0a EEPROM read error</td> </tr> <tr> <td>04 FLASH ROM write error (Program section)</td> <td>0b EEPROM verify error</td> </tr> <tr> <td>05 Sum check error (Loader section)</td> <td>0F Download data length error</td> </tr> <tr> <td>06 Sum check error (Boot section)</td> <td>0E EEPROM size error</td> </tr> <tr> <td>07 Sum check error (Program section)</td> <td></td> </tr> </tbody> </table>	Status	7-seg display	POWER SAVE indicator	DUAL PAGE COPY indicator	Download data reception	d	ON	OFF	Data delete start	d	OFF	ON	Data write (Boot section)	d	Flash	OFF	Data write (Program section)	d	Flash	Flash	Sum check	d	ON	ON	Download end	OFF	OFF	OFF	Error status	E*	OFF	OFF	00 Data receive error	08 Sum check error (EEPROM section)	02 FLASH ROM delete error	09 EEPROM write error	03 FLASH ROM write error (Boot section)	0a EEPROM read error	04 FLASH ROM write error (Program section)	0b EEPROM verify error	05 Sum check error (Loader section)	0F Download data length error	06 Sum check error (Boot section)	0E EEPROM size error	07 Sum check error (Program section)	
Status	7-seg display	POWER SAVE indicator	DUAL PAGE COPY indicator																																														
Download data reception	d	ON	OFF																																														
Data delete start	d	OFF	ON																																														
Data write (Boot section)	d	Flash	OFF																																														
Data write (Program section)	d	Flash	Flash																																														
Sum check	d	ON	ON																																														
Download end	OFF	OFF	OFF																																														
Error status	E*	OFF	OFF																																														
00 Data receive error	08 Sum check error (EEPROM section)																																																
02 FLASH ROM delete error	09 EEPROM write error																																																
03 FLASH ROM write error (Boot section)	0a EEPROM read error																																																
04 FLASH ROM write error (Program section)	0b EEPROM verify error																																																
05 Sum check error (Loader section)	0F Download data length error																																																
06 Sum check error (Boot section)	0E EEPROM size error																																																
07 Sum check error (Program section)																																																	

Main code	Sub code	Contents	Details of operation																
50	01	Image lead edge adjustment	<p>Used to adjust the copy image position and the lead edge void amount on the copy paper. This adjustment is made by adjusting the image scan start position at 100% and the print start position (resist roller ON timing).</p> <p><b>(Operating procedure)</b>  When this simulation is executed, the current set value is displayed in two digits. (Center value: 50)  When the [AUTO/TEXT/PHOTO] key is pressed, the setting mode and the display are switched.  Enter the adjustment value with the Numeric keys and press the [START] key, and the entered value is set and a copy is made. (Adjustment range 1 ~ 99) When the [Interrupt] key is pressed, the entered value is saved and the machine goes into the sub code entry standby mode. When the [CA] key is pressed, the entered value is saved and the simulation is terminated. When the adjustment is made with 1st tray paper feed, all the adjustment values at the paper feed ports become the same. (When the adjustment value is increased by 1, the position is shifted by about 0.1mm.)</p> <table border="1"> <thead> <tr> <th>LED</th> <th>Adjustment mode</th> </tr> </thead> <tbody> <tr> <td>AUTO, 1st tray indicator</td> <td>Print start position (1st tray paper feed)</td> </tr> <tr> <td>AUTO, 2nd tray indicator</td> <td>★ Print start position (2nd / 3rd / 4th tray paper feed)</td> </tr> <tr> <td>AUTO, Bypass tray indicator</td> <td>Print start position (Bypass tray)</td> </tr> <tr> <td>TEXT indicator</td> <td>Image lead edge void amount</td> </tr> <tr> <td>PHOTO indicator</td> <td>Image scan start position</td> </tr> <tr> <td>AUTO, TEXT, PHOTO indicator</td> <td>Image rear edge void amount</td> </tr> </tbody> </table> <p>* The mark, "★", indicates that it is supported only for the installed model, and it is skipped for non-installed models.</p> <p>Note: When printing is made with bypass tray, use A3 paper.  When the adjustment value of the print start position is increased by 1, the resist roller ON timing is delayed and the print image is reduced by 0.1mm. When the adjustment value of the image scan start position is increased by 1, the scan start position is shifted to the home position by 0.1mm.</p> <p><b>[Adjustment procedure]</b>  (1) Set the print start position (A) (AUTO exposure ON), the lead edge void amount (B) (TEXT ON), and the scan start position (C) (PHOTO ON) to &lt;1&gt;, and make a 100% copy.  (2) Measure the image loss (R mm) of the scale. Set as C=10 x R (mm). (Example: Set to 40.)  When the value of C is increased by 10, the image loss is decreased by 1mm. (Default: 50)  (3) Measure the distance between the paper lead edge and the image print start position.  Set as A=10 x H (mm). (Example: Set to 50.)  When the value of A is increased by 10, the image lead edge is shifted toward the paper lead edge by 1mm. (Default: 50)  (4) Set the lead edge void area as B=50 (2.5mm). (Default: 50)  When the value of B is increased by 10, the void is increased by about 1mm.  (For 25 or less, however, the void amount is zero.)</p> <p><b>(Example)</b></p>	LED	Adjustment mode	AUTO, 1st tray indicator	Print start position (1st tray paper feed)	AUTO, 2nd tray indicator	★ Print start position (2nd / 3rd / 4th tray paper feed)	AUTO, Bypass tray indicator	Print start position (Bypass tray)	TEXT indicator	Image lead edge void amount	PHOTO indicator	Image scan start position	AUTO, TEXT, PHOTO indicator	Image rear edge void amount		
LED	Adjustment mode																		
AUTO, 1st tray indicator	Print start position (1st tray paper feed)																		
AUTO, 2nd tray indicator	★ Print start position (2nd / 3rd / 4th tray paper feed)																		
AUTO, Bypass tray indicator	Print start position (Bypass tray)																		
TEXT indicator	Image lead edge void amount																		
PHOTO indicator	Image scan start position																		
AUTO, TEXT, PHOTO indicator	Image rear edge void amount																		
06		Copy lead edge position adjustment (RSPF) (Only when the RSPF is installed)	<p>Used to make the SPF copy lead edge position adjustment.</p> <p>* When the adjustment value of the document scan start position is increased by 1, the scan start timing is advanced by 0.1mm. The print image is shifted to the reverse side of the scan start position.  (Adjustment range: 1 ~ 99, Default: 50)</p> <p><b>&lt;Adjustment items&gt;</b></p> <table border="1"> <thead> <tr> <th>LED</th> <th>Item</th> <th>Default</th> <th>Variable range</th> </tr> </thead> <tbody> <tr> <td>AUTO indicator</td> <td>Front document scan position adjustment</td> <td>50</td> <td>1 ~ 99</td> </tr> <tr> <td>TEXT indicator</td> <td>Back document scan position adjustment</td> <td>50</td> <td>1 ~ 99</td> </tr> <tr> <td>PHOTO indicator</td> <td>Rear edge void adjustment (SPF)</td> <td>50</td> <td>1 ~ 99</td> </tr> </tbody> </table>	LED	Item	Default	Variable range	AUTO indicator	Front document scan position adjustment	50	1 ~ 99	TEXT indicator	Back document scan position adjustment	50	1 ~ 99	PHOTO indicator	Rear edge void adjustment (SPF)	50	1 ~ 99
LED	Item	Default	Variable range																
AUTO indicator	Front document scan position adjustment	50	1 ~ 99																
TEXT indicator	Back document scan position adjustment	50	1 ~ 99																
PHOTO indicator	Rear edge void adjustment (SPF)	50	1 ~ 99																

Main code	Sub code	Contents	Details of operation																
50	10	Paper off-center adjustment	<p>Used to adjust the positions of copy images on copy paper and the center offset position when scanning the document.</p> <p><b>(Operating procedure)</b>            When this simulation is executed, the current set value is displayed. Enter the adjustment value with the Numeric keys and press the [START] key, and the entered value is stored and a copy is made. When the [Interrupt] key is pressed, the entered value is saved and the machine goes into the sub code entry standby mode. When the [CA] key is pressed, the entered value is saved and the simulation is terminated.            (When the set value is increased by 1, the position is shifted by 0.1mm.)            (Adjustment range: 1 ~ 99, Default: 50)</p> <p><b>&lt;Supplement&gt;</b>            When the adjustment value is increased, the image is shifted to the left. When the adjustment value is decreased, the image is shifted to the right.</p> <table border="1"> <thead> <tr> <th>LED</th> <th>Adjustment mode</th> </tr> </thead> <tbody> <tr> <td>AUTO, 1st tray indicator</td> <td>Print center offset (1st tray paper feed)</td> </tr> <tr> <td>AUTO, 2nd tray indicator</td> <td>★ Print center offset (2nd tray paper feed)</td> </tr> <tr> <td>AUTO, 3rd tray indicator</td> <td>★ Print center offset (3rd tray paper feed)</td> </tr> <tr> <td>AUTO, 4th tray indicator</td> <td>★ Print center offset (4th tray paper feed)</td> </tr> <tr> <td>AUTO, Bypass tray indicator</td> <td>Print center offset (Bypass tray)</td> </tr> <tr> <td>TEXT, 1st tray indicator</td> <td>2nd print center offset (1st tray paper feed)</td> </tr> <tr> <td></td> <td>When this mode is selected, the S-D mode is automatically set.</td> </tr> </tbody> </table> <p>★ Supported for the installed models only. Skipped for the models without installation.            Note: When the adjustment value is too great, the outside area of shading may be scanned, resulting in black streaks on copy paper.            When printing is made with bypass tray, use A3 paper.            When a document is scanned in the OC mode in the back surface center off-set adjustment and printing is made in the S-D mode, the first document is scanned and then the second document is scanned automatically.</p>	LED	Adjustment mode	AUTO, 1st tray indicator	Print center offset (1st tray paper feed)	AUTO, 2nd tray indicator	★ Print center offset (2nd tray paper feed)	AUTO, 3rd tray indicator	★ Print center offset (3rd tray paper feed)	AUTO, 4th tray indicator	★ Print center offset (4th tray paper feed)	AUTO, Bypass tray indicator	Print center offset (Bypass tray)	TEXT, 1st tray indicator	2nd print center offset (1st tray paper feed)		When this mode is selected, the S-D mode is automatically set.
LED	Adjustment mode																		
AUTO, 1st tray indicator	Print center offset (1st tray paper feed)																		
AUTO, 2nd tray indicator	★ Print center offset (2nd tray paper feed)																		
AUTO, 3rd tray indicator	★ Print center offset (3rd tray paper feed)																		
AUTO, 4th tray indicator	★ Print center offset (4th tray paper feed)																		
AUTO, Bypass tray indicator	Print center offset (Bypass tray)																		
TEXT, 1st tray indicator	2nd print center offset (1st tray paper feed)																		
	When this mode is selected, the S-D mode is automatically set.																		
	12	Document off-center adjustment	<p>Used to make the document scan off-center adjustment.            (Adjustment range: 1 ~ 99, Default: 50)</p> <p>* When the adjustment value is increased by 1, the print image is shifted by 0.1mm to the left when the scan start position is put on the upper side.</p> <p><b>&lt;Adjustment item&gt;</b></p> <table border="1"> <thead> <tr> <th>LED</th> <th>Item</th> <th>Default</th> <th>Variable range</th> </tr> </thead> <tbody> <tr> <td>AUTO indicator</td> <td>Platen document scan</td> <td>50</td> <td>1 ~ 99</td> </tr> <tr> <td>TEXT indicator</td> <td>SPF document front scan (Only when the RSPF is installed)</td> <td>50</td> <td>1 ~ 99</td> </tr> <tr> <td>PHOTO indicator</td> <td>RSPF document back scan (Only when the RSPF is installed)</td> <td>50</td> <td>1 ~ 99</td> </tr> </tbody> </table>	LED	Item	Default	Variable range	AUTO indicator	Platen document scan	50	1 ~ 99	TEXT indicator	SPF document front scan (Only when the RSPF is installed)	50	1 ~ 99	PHOTO indicator	RSPF document back scan (Only when the RSPF is installed)	50	1 ~ 99
LED	Item	Default	Variable range																
AUTO indicator	Platen document scan	50	1 ~ 99																
TEXT indicator	SPF document front scan (Only when the RSPF is installed)	50	1 ~ 99																
PHOTO indicator	RSPF document back scan (Only when the RSPF is installed)	50	1 ~ 99																

Main code	Sub code	Contents	Details of operation								
50	18	Duplex copy memory reverse position adjustment (Only when the RSPF is installed or in the duplex mode)	<p>Used to adjust the memory reverse position in duplex copy. When this simulation is executed, the current correction value is displayed. Enter a correction value with the Numeric keys and press the [START] key, and the entered value will be saved. (Adjustment range: 1 ~ 99, Default: 50)</p> <table border="1"> <thead> <tr> <th>LED</th> <th>Item</th> </tr> </thead> <tbody> <tr> <td>AUTO indicator</td> <td>OC memory reverse output position</td> </tr> <tr> <td>TEXT indicator</td> <td>SPF memory reverse output position</td> </tr> </tbody> </table> <p>Printing of the front surface in the S-D mode and printing of the even pages in the D-S mode are performed as reverse memory copying from the rear edge of the document. When, therefore, the printing position adjustment of output image is required, perform the adjustment as follows: The image direction in reverse memory copying is shown in the figure below. That is, when the document scan direction is as shown with the arrow, the output image is printed from the rear edge of scanning. If, therefore, the print edge section is shifted, set the reference chart with the reference position at the rear edge and use this simulation to change the set value in order to adjust the print lead edge position. Since printing is started at the print start position and performed from the last, saved data in the memory to the head data, the lead edge position of an image is adjusted by changing the last data position saved in the memory.</p> <p>Note:A document is scanned in the OC mode. When printing is made in the S-D mode, the first document is scanned and then the second document is automatically scanned.</p>	LED	Item	AUTO indicator	OC memory reverse output position	TEXT indicator	SPF memory reverse output position		
LED	Item										
AUTO indicator	OC memory reverse output position										
TEXT indicator	SPF memory reverse output position										
	19	Duplex copy rear edge void adjustment (Duplex model only)	<p>Used to adjust the rear edge void amount in duplex copy.</p> <p><b>(Operating procedure)</b> When this simulation is executed, the current set value is displayed in two digits. (Adjustment range: 1 ~ 99, Center value: 50) * When the set value is increased by 1, the void amount is increased by about 0.1mm. Press the [AUTO/TEXT/PHOTO] key to select a suitable setting mode and a display. Enter the adjustment value with the Numeric keys and press the [START] key, and the entered value is saved and a copy is made. (Paper information is cleared after every copying). When the [Interrupt] key is pressed, the entered value is saved and the machine goes into the sub code entry standby mode. When the [CA] key is pressed, the entered value is saved and the simulation is terminated.</p> <table border="1"> <thead> <tr> <th>LED</th> <th>Item</th> </tr> </thead> <tbody> <tr> <td>AUTO indicator</td> <td>Paper rear edge void amount (First print surface)</td> </tr> <tr> <td>TEXT indicator</td> <td>Paper rear edge void amount (Second print surface)</td> </tr> <tr> <td>PHOTO indicator</td> <td>Print start position (duplex back surface)</td> </tr> </tbody> </table>	LED	Item	AUTO indicator	Paper rear edge void amount (First print surface)	TEXT indicator	Paper rear edge void amount (Second print surface)	PHOTO indicator	Print start position (duplex back surface)
LED	Item										
AUTO indicator	Paper rear edge void amount (First print surface)										
TEXT indicator	Paper rear edge void amount (Second print surface)										
PHOTO indicator	Print start position (duplex back surface)										

Main code	Sub code	Contents	Details of operation																																	
51	02	Resist amount adjustment	<p>Used to adjust the contact pressure of the machine resist roller and the RSPF resist roller onto the paper.</p> <p><b>(Operating procedure)</b>  When this simulation is executed, the current set value is displayed.  When the [AUTO/TEXT/PHOTO] key is pressed, the following set items are changed sequentially.  Enter an adjustment value with the Numeric keys and press the [START] key, and the entered value will be saved and a copy will be made. (Adjustment range: 1 ~ 99)  When the [CA] key is pressed, the entered value is saved and the simulation is terminated.</p> <table border="1"> <thead> <tr> <th>LED</th> <th>Adjustment mode</th> <th>Default</th> </tr> </thead> <tbody> <tr> <td>AUTO, 1st tray indicator</td> <td>1st tray paper feed</td> <td>50</td> </tr> <tr> <td>AUTO, 2nd tray indicator</td> <td>★ 2nd tray paper feed</td> <td>50</td> </tr> <tr> <td>AUTO, 3rd tray indicator</td> <td>★ 3rd tray paper feed</td> <td>50</td> </tr> <tr> <td>AUTO, 4th tray indicator</td> <td>★ 4th tray paper feed</td> <td>50</td> </tr> <tr> <td>AUTO, Bypass tray indicator</td> <td>Bypass tray</td> <td>50</td> </tr> <tr> <td>AUTO, TEXT, PHOTO indicator</td> <td>★ RSPF document feed (Front surface)</td> <td>50</td> </tr> <tr> <td>AUTO, TEXT indicator</td> <td>★ RSPF document feed (Back surface)</td> <td>50</td> </tr> <tr> <td>AUTO, PHOTO indicator</td> <td>★ RSPF document (A5) paper feed (Back surface)</td> <td>50</td> </tr> <tr> <td>TEXT, PHOTO indicator</td> <td>★ Duplex back surface</td> <td>50</td> </tr> <tr> <td>TEXT indicator</td> <td>PS solenoid prior pulling time adjustment in manual paper feed</td> <td>32</td> </tr> </tbody> </table> <p>★ Supported for the installed models only. Skipped for the models without installation.</p>	LED	Adjustment mode	Default	AUTO, 1st tray indicator	1st tray paper feed	50	AUTO, 2nd tray indicator	★ 2nd tray paper feed	50	AUTO, 3rd tray indicator	★ 3rd tray paper feed	50	AUTO, 4th tray indicator	★ 4th tray paper feed	50	AUTO, Bypass tray indicator	Bypass tray	50	AUTO, TEXT, PHOTO indicator	★ RSPF document feed (Front surface)	50	AUTO, TEXT indicator	★ RSPF document feed (Back surface)	50	AUTO, PHOTO indicator	★ RSPF document (A5) paper feed (Back surface)	50	TEXT, PHOTO indicator	★ Duplex back surface	50	TEXT indicator	PS solenoid prior pulling time adjustment in manual paper feed	32
LED	Adjustment mode	Default																																		
AUTO, 1st tray indicator	1st tray paper feed	50																																		
AUTO, 2nd tray indicator	★ 2nd tray paper feed	50																																		
AUTO, 3rd tray indicator	★ 3rd tray paper feed	50																																		
AUTO, 4th tray indicator	★ 4th tray paper feed	50																																		
AUTO, Bypass tray indicator	Bypass tray	50																																		
AUTO, TEXT, PHOTO indicator	★ RSPF document feed (Front surface)	50																																		
AUTO, TEXT indicator	★ RSPF document feed (Back surface)	50																																		
AUTO, PHOTO indicator	★ RSPF document (A5) paper feed (Back surface)	50																																		
TEXT, PHOTO indicator	★ Duplex back surface	50																																		
TEXT indicator	PS solenoid prior pulling time adjustment in manual paper feed	32																																		
53	08	SPF scanning position automatic adjustment (Only when the RSPF is installed)	<p>Place the white chart so that it covers both the SPF scan glass and the OC glass. Close the OC cover. When this simulation is executed, the current adjustment value is displayed as the initial display. When the [START] key is pressed, the mirror unit scans from the home position to the SPF scan position with the current adjustment value displayed, and the SPF glass cover edge is calculated from the difference between the SPF glass cover edge and the OC side document glass CCD output level.</p> <p>* The default is 50, the adjustment range is 1 ~ 99, and the adjustment unit 1= about 0.127mm.  If the adjustment is completed normally, the adjusted value is displayed. If not, the Misfeed indicator lights up with the current set value displayed. When the [START] key is pressed again with the Misfeed indicator ON, the execution is repeated again. When the [Interrupt] key or the [CA] key is pressed during execution, "- -" is displayed and the operation is canceled. The mirror returns to its home position and the simulation mode is terminated. In the case when the [Interrupt] key is pressed, the machine goes into the sub code input standby mode. In the case when the [CA] key is pressed, all the lamps are turned off.</p> <table border="1"> <thead> <tr> <th>LED</th> <th>Display mode</th> </tr> </thead> <tbody> <tr> <td>AUTO indicator</td> <td>SPF scan position automatic adjustment</td> </tr> <tr> <td>TEXT indicator</td> <td>SPF scan position manual adjustment</td> </tr> </tbody> </table>	LED	Display mode	AUTO indicator	SPF scan position automatic adjustment	TEXT indicator	SPF scan position manual adjustment																											
LED	Display mode																																			
AUTO indicator	SPF scan position automatic adjustment																																			
TEXT indicator	SPF scan position manual adjustment																																			
	10	SPF document scan position select setting	<p>Setting is changed depending on whether the SPF unit and the SPF document glass holding section are glass dirt prevention parts or not.</p> <p>For the combination of this machine and the AR-RP10, the set value is set to [1].  If the set value is changed to [0], black streaks may be produced on a copy paper due to dirt on the SPF glass.</p> <p>When this simulation is executed, the current code number is displayed.  Enter a code number corresponding to the SPF unit to be used and press [START] key to save the setting.</p> <table border="1"> <thead> <tr> <th>Code number</th> <th>Mode</th> </tr> </thead> <tbody> <tr> <td>0</td> <td>Set to the scan position equivalent to the old-type SPF unit (the previous model of AR-SP6/RP6).</td> </tr> <tr> <td>1</td> <td>Set to the scan position for dirt prevention. *Default</td> </tr> </tbody> </table> <p>Though this setting is changed, the other adjustment values are not affected. (The set value remain unchanged.)  When replacing or installing the SPF unit, perform this simulation to set the position and then execute the scan position automatic adjustment.</p>	Code number	Mode	0	Set to the scan position equivalent to the old-type SPF unit (the previous model of AR-SP6/RP6).	1	Set to the scan position for dirt prevention. *Default																											
Code number	Mode																																			
0	Set to the scan position equivalent to the old-type SPF unit (the previous model of AR-SP6/RP6).																																			
1	Set to the scan position for dirt prevention. *Default																																			
60	01	SDRAM (image memory area) access check	<p>Access check to the SDRAM is made.</p> <p>When this simulation is executed, the SDRAM check is started. Fusing execution. the start LED turns OFF. If an error occurs, the following LED turns ON. When the operation is normally completed, the START indicator is turned ON.  After completion of checking, press [CA] key to reboot the machine.</p> <table border="1"> <thead> <tr> <th>LED</th> <th>Display mode</th> </tr> </thead> <tbody> <tr> <td>Misfeed indicators</td> <td>Write end error</td> </tr> <tr> <td>Paper required indicator</td> <td>Read end error</td> </tr> </tbody> </table>	LED	Display mode	Misfeed indicators	Write end error	Paper required indicator	Read end error																											
LED	Display mode																																			
Misfeed indicators	Write end error																																			
Paper required indicator	Read end error																																			

Main code	Sub code	Contents	Details of operation																																																
61	02	Laser power correction ON/OFF	Used to set whether the laser power correction is performed or not halfway. When [START] key is pressed, the entered value is saved and the screen shifts to the sub code input standby mode. <table border="1" style="margin-left: 20px;"> <thead> <tr> <th>Code number</th> <th>Mode</th> </tr> </thead> <tbody> <tr> <td>0</td> <td>Not correct</td> </tr> <tr> <td>1</td> <td>Correct *Default</td> </tr> </tbody> </table>	Code number	Mode	0	Not correct	1	Correct *Default																																										
	Code number	Mode																																																	
0	Not correct																																																		
1	Correct *Default																																																		
03	HSYNC output check	When the [START] key is pressed, HSYNC is performed and the polygon motor is rotated for 30 sec. Every time when HSYNC is detected, the zoom lamp lights up.																																																	
63	01	Shading check	The detection level of the white plate for shading is displayed. <b>(Operating procedure)</b> When the [START] key is pressed in the sub code input standby mode, the mirror base unit moves to the white plate for shading and the copy lamp is lighted. Until the light quantity of the copy lamp is stabilized, the sub code of "01" is displayed on the 7-seg display. When the light quantity of the copy lamp is stabilized, it is revised every second, and the level of one pixel at the CCD center where no correction is made is detected for 10 sec, and the detected level is displayed in hexadecimal on the 7-seg display. After completion of 10 sec detection, the machine goes into the sub code input standby mode.																																																
	07	SPF automatic correction (Only when the RSPF is installed)	The SPF white correction start pixel position is automatically adjusted. This is performed after replacement of the lens. Open the SPF unit and press the [START] key, and the position (which pixel) of the white sheet for SPF exposure correction in the SPF position is displayed on the 7-seg display. If the value is 93 ~ 229, it is displayed on the 7-seg display and is written into the EEPROM. If the value is 0 ~ 92 or 230 ~ 999, it is displayed on the 7-seg display but is not written into the EEPROM. If the value is 1000 or above, "-----" is displayed on the 7-seg display and is not written into the EEPROM. The pixel position -34 written into the EEPROM is considered as the SPF white correction start pixel of the machine. When shi simulation is executed with the SPF unit closed, an error will occur.																																																
64	01	Self print	The optical system status is ignored and a self print is made. Also when a print command is sent from the host, printing is performed. <b>(Operating procedure)</b> When this simulation is executed, warm-up is performed and the START indicator is lighted. (However, the scanner is invalid and no initial operation is made.) Enter the code number with the Numeric keys, and select a tray with the PAPER SELECT key and press the [START] key. The selected tray start paper feed and printing is performed in the selected pattern. * Only the tray lamp and the online lamp are lighted, and no other lamps are lighted. <table border="1" style="margin-left: 20px;"> <thead> <tr> <th>Code number</th> <th>Print pattern</th> <th>Image output</th> <th>Lighted LED</th> </tr> </thead> <tbody> <tr> <td>0</td> <td>Grid pattern</td> <td>&lt;1&gt;1/236 &lt;2&gt;1/128 &lt;3&gt;1/255 &lt;4&gt;2/254</td> <td>AUTO indicator TEXT indicator PHOTO indicator AUTO indicator &amp; TEXT indicator</td> </tr> <tr> <td>1</td> <td>Dot pattern</td> <td>&lt;1&gt;1/1 &lt;2&gt;2/2 &lt;3&gt;1/255</td> <td>AUTO indicator TEXT indicator PHOTO indicator</td> </tr> <tr> <td>2</td> <td>Regular pitch pattern MbyN (Sub scan)</td> <td>&lt;1&gt;1/1 &lt;2&gt;1/2 &lt;3&gt;2/2</td> <td>AUTO indicator TEXT indicator PHOTO indicator</td> </tr> <tr> <td>3</td> <td>Regular pitch pattern MbyN (Main scan)</td> <td>&lt;1&gt;1/1 &lt;2&gt;1/2 &lt;3&gt;2/2</td> <td>AUTO indicator TEXT indicator PHOTO indicator</td> </tr> <tr> <td>4</td> <td>Black background belt (A4/A4R)(Paper F-R end)</td> <td>&lt;1&gt;1% &lt;2&gt;6% &lt;3&gt;35%</td> <td>AUTO indicator TEXT indicator PHOTO indicator</td> </tr> <tr> <td>5</td> <td>Black background belt (All surface)</td> <td>No pattern</td> <td>AUTO indicator</td> </tr> <tr> <td>6</td> <td>White background belt (All surface)</td> <td>No pattern</td> <td>AUTO indicator</td> </tr> <tr> <td>7</td> <td>ht(All surface)</td> <td>No pattern</td> <td>AUTO indicator</td> </tr> <tr> <td>8</td> <td>Black square</td> <td>No pattern</td> <td>AUTO indicator</td> </tr> <tr> <td>9</td> <td>Lead edge black</td> <td>No pattern</td> <td>AUTO indicator</td> </tr> <tr> <td>10</td> <td>Form of 田</td> <td>No pattern</td> <td>AUTO indicator</td> </tr> </tbody> </table>	Code number	Print pattern	Image output	Lighted LED	0	Grid pattern	<1>1/236 <2>1/128 <3>1/255 <4>2/254	AUTO indicator TEXT indicator PHOTO indicator AUTO indicator & TEXT indicator	1	Dot pattern	<1>1/1 <2>2/2 <3>1/255	AUTO indicator TEXT indicator PHOTO indicator	2	Regular pitch pattern MbyN (Sub scan)	<1>1/1 <2>1/2 <3>2/2	AUTO indicator TEXT indicator PHOTO indicator	3	Regular pitch pattern MbyN (Main scan)	<1>1/1 <2>1/2 <3>2/2	AUTO indicator TEXT indicator PHOTO indicator	4	Black background belt (A4/A4R)(Paper F-R end)	<1>1% <2>6% <3>35%	AUTO indicator TEXT indicator PHOTO indicator	5	Black background belt (All surface)	No pattern	AUTO indicator	6	White background belt (All surface)	No pattern	AUTO indicator	7	ht(All surface)	No pattern	AUTO indicator	8	Black square	No pattern	AUTO indicator	9	Lead edge black	No pattern	AUTO indicator	10	Form of 田	No pattern	AUTO indicator
Code number	Print pattern	Image output	Lighted LED																																																
0	Grid pattern	<1>1/236 <2>1/128 <3>1/255 <4>2/254	AUTO indicator TEXT indicator PHOTO indicator AUTO indicator & TEXT indicator																																																
1	Dot pattern	<1>1/1 <2>2/2 <3>1/255	AUTO indicator TEXT indicator PHOTO indicator																																																
2	Regular pitch pattern MbyN (Sub scan)	<1>1/1 <2>1/2 <3>2/2	AUTO indicator TEXT indicator PHOTO indicator																																																
3	Regular pitch pattern MbyN (Main scan)	<1>1/1 <2>1/2 <3>2/2	AUTO indicator TEXT indicator PHOTO indicator																																																
4	Black background belt (A4/A4R)(Paper F-R end)	<1>1% <2>6% <3>35%	AUTO indicator TEXT indicator PHOTO indicator																																																
5	Black background belt (All surface)	No pattern	AUTO indicator																																																
6	White background belt (All surface)	No pattern	AUTO indicator																																																
7	ht(All surface)	No pattern	AUTO indicator																																																
8	Black square	No pattern	AUTO indicator																																																
9	Lead edge black	No pattern	AUTO indicator																																																
10	Form of 田	No pattern	AUTO indicator																																																

\* When the destination is of AB series, print data are made in A3 size.  
(Therefore, A3 paper is desirable.)

\* When the destination is of inch series, print data are made in WLT size.  
(Therefore, WLT paper is desirable.)

## [8] TROUBLE CODE LIST

### 1. Trouble code list

Main code	Sub code	Content	
E7	01	Duplex model memory error/ Image data error	
	02	LSU trouble	
	06	Image data decode error	
	10	Shading trouble (Black correction)	
	11	Shading trouble (White correction)	
	16	Abnormal laser output	
F2	40	ATC sensor abnormality	
	64	Toner supply abnormality	
	70	Improper cartridge (destination error, life cycle error)	
		Identification error	
		Model error	
		Type error	
		Destination error	
		Data abnormality	
		Misc error	
	74	CRUM chip communication error	
F5	02	Copy lamp lighting abnormality	
H2	00	Thermistor open (MAIN)	
	01	Thermistor open (SUB)	
H3	00	Heat roller high temperature detection (MAIN)	
	01	Heat roller high temperature detection (SUB)	
H4	00	Heat roller low temperature detection	
H5	01	5 continuous POUT not-reached error	
L1	00	Scanner feed trouble	
L3	00	Scanner return trouble	
L4	01	Main motor lock detection	
	31	Fusing FAN lock detection	
	32	PSFAN lock detection	
L6	10	Polygon motor lock detection	
U2	04	EEPROM read/write error (serial communication error)	
	11	Counter check sum error (EEPROM)	
	12	Adjustment value check sum error (EEPROM)	
CH ON	None	Door open	
CH Blink	None	Developing cartridge not installed	

### 2. Details of trouble codes

Main code	Sub code	Details of trouble		
E7	01	Content	Duplex model memory error/ Image data error	
		Detail	1. The memory capacity for the duplex model machine is wrong. Insufficient memory capacity. 2. Duplex setting is set for a single surface model.	
		Cause	1. The memory capacity on the MCU PWB is wrong. 2. Setting for a single surface model is wrong.	
		Check and remedy	1. Use SIM26-39 to check to confirm that the memory capacity is 64MB. If it is not 64MB, replace the MCU PWB. 2. If SIM26-04 is set to 1, change the setting to 0. If it is 0, replace the MCU PWB.	
		02	Content	LSU trouble
		Detail	The BD signal from the LSU cannot be detected in a certain cycle. (Always OFF or always ON)	
	Cause	LSU connector or LSU harness defect or disconnection Polygon motor rotation abnormality Laser beams are not generated. MCU PWB abnormality.		
	Check and remedy	Check connection of the LSU connector. Execute SIM 61-03 to check the LSU operations. Check that the polygon motor rotates normally. Check that the laser emitting diode generates laser beams. Replace the LSU unit. Replace the MCU PWB.		
	06	Content	Image data decode error	
	Detail	Image expansion error		
	Cause	MCU PWB abnormality USB cable trouble		
	Check and remedy	Replace the MCU PWB. Replace the USB cable.		
10	Content	Shading trouble (Black correction)		
	Detail	The CCD black scan level is abnormal when the shading.		
	Cause	Improper connection of the CCD unit flat cable CCD unit abnormality MCU PWB abnormality.		
	Check and remedy	Check connection of the CCD unit flat cable. Check the CCD unit.		
	11	Content	Shading trouble (White correction)	
	Detail	The CCD white scan level is abnormal when the shading.		
Cause	Improper connection of the CCD unit flat cable Dirt on the mirror, the lens, and the reference white plate Copy lamp lighting abnormality CCD unit abnormality MCU PWB abnormality (When occurred in the SPF scan position.) Improper installation of the mirror unit			
Check and remedy	Clean the mirror, the lens, and the reference white plate. Check lighting and the light quantity of the copy lamp (SIM05-03). Check the CCD unit. Check the MCU PWB.			

Main code	Sub code		Details of trouble
E7	16	Content	Abnormal laser output
		Detail	When the laser output is stopped, HSYNC is detected.
		Cause	Laser abnormality MCU PWB abnormality.
		Check and remedy	Replace the LSU. Replace the MCU PWB.
F2	40	Content	ATC sensor abnormality
		Detail	ATC sensor value abnormality
		Cause	Connector connection trouble Toner cartridge installation trouble Sensor breakdown
		Check and remedy	Connect the connector again. Install the developing unit again. Replace the developing unit with a normal one.
	64	Content	Toner supply abnormality
		Detail	When toner near end is detected with the toner supply time of 50% or less. When the toner supply time exceeds 300%.
		Cause	ATC sensor abnormality Toner supply abnormality
		Check and remedy	Replace the toner cartridge. Replace the developing unit.
	70	Content	<ul style="list-style-type: none"> <li>•Improper cartridge (Destination error, life cycle error)</li> <li>•Identification error</li> <li>•Model error</li> <li>•Type error</li> <li>•Destination error</li> <li>•Data abnormality</li> <li>•Misc error</li> </ul>
		Detail	<ul style="list-style-type: none"> <li>•The destination of the machine differs from that of the CRUM.</li> <li>•The trade mark code of the CRUM differs.</li> <li>•The company code of the CRUM differs.</li> <li>•The boot program model code does not coincide with the CRUM model code.</li> <li>•When the CRUM type is other than genuine/conversion/production rotation.</li> <li>•The machine destination differs from the CRUM destination.</li> </ul>
		Cause	CRUM chip defect Improper toner cartridge.
		Check and remedy	Replace the toner cartridge.
74		Content	CRUM chip communication error
		Detail	An error occurs during communication between the MCU and the CRUM chip. The CRUM identification error occurs.
	Cause	CRUM chip abnormality Developing unit disconnection MCU PWB abnormality	
	Check and remedy	Replace the toner cartridge. Check installation of the developing unit. Use SIM16 to cancel. Replace the MCU PWB.	

Main code	Sub code		Details of trouble
F5	02	Content	Copy lamp lighting abnormality
		Detail	The copy lamp does not turn on.
		Cause	Copy lamp abnormality Copy lamp harness abnormality CCD PWB harness abnormality.
		Check and remedy	Use SIM 5-3 to check the copy lamp operations. <b>When the copy lamp lights up.</b> Check the harness and the connector between the CCD unit and the MCU PWB. <b>When the copy lamp does not light up.</b> Check the harness and the connector between the copy lamp unit and the MCU PWB. Replace the copy lamp unit. Replace the MCU PWB. "
H2	00	Content	Thermistor open (MAIN)
		Detail	The thermistor is open. The fusing unit is not installed.
		Cause	Thermistor abnormality Control PWB abnormality Fusing section connector disconnection The fusing unit is not installed.
		Check and remedy	Check the harness and the connector between the thermistor and the PWB. Cancel the trouble with SIM 14.
	01	Content	Thermistor open (SUB)
		Detail	The sub thermistor is open. The fusing unit is not installed.
		Cause	Sub thermistor abnormality Heater lamp abnormality Thermostat abnormality Main PWB abnormality
		Check and remedy	Use SIM 5-02 to check the heater lamp blinking operation. <b>When normally lighting.</b> Check the sub thermistor and its harness. Check the sub thermistor input circuit on the MAIN PWB. <b>When not normally lighting.</b> Check the lamp control circuit on the MCU PWB. Cancel the trouble with SIM 14.

Main code	Sub code		Details of trouble
H3	00	Content	Heat roller high temperature detection (MAIN)
		Detail	The fusing temperature exceeds 245°C.
		Cause	Thermistor abnormality Control PWB abnormality Fusing section connector disconnection.
	01	Content	Heat roller high temperature detection (SUB)
		Detail	The fusing temperature exceeds 245°C.
		Cause	Sub thermistor abnormality Heater lamp abnormality Thermostat abnormality Main PWB abnormality
00	Check and remedy	Use SIM 5-02 to check the heater lamp blinking operation. <b>When the lamp blinks normally.</b> Check the thermistor and its harness. Check the thermistor input circuit on the control PWB. <b>When the lamp keeps ON.</b> Check the power PWB and the lamp control circuit on the MCU PWB. Cancel the trouble with SIM 14.	
	Check and remedy	Use SIM 5-02 to check the heater lamp blinking operation. <b>When normally lighting.</b> Check the sub thermistor and its harness. Check the sub thermistor input circuit on the MAIN PWB. <b>When not normally lighting.</b> Check the lamp control circuit on the MCU PWB. Cancel the trouble with SIM 14.	
	Check and remedy	Use SIM 5-02 to check the heater lamp blinking operation. <b>When the lamp blinks normally.</b> Check the thermistor and its harness. Check the thermistor input circuit on the control PWB. <b>When the lamp does not light up.</b> Check for disconnection of the heater lamp and the thermostat. Check the interlock switch. Check the power PWB and the lamp control circuit on the MCU PWB. Cancel the trouble with SIM 14.	

Main code	Sub code		Details of trouble
H5	01	Content	5 continuous POUT not-reached error
		Detail	When 5 continuous not-reached jams to the paper exit sensor (POUT) occur. The jam counter is backed up and it is used in a job after turning on the power.
		Cause	Jam paper is not removed from the fusing unit. (Jam paper remains.) Paper exit sensor breakdown or harness connection trouble Fusing unit installation trouble
		Check and remedy	Check for jam paper remaining in the fusing unit. (winding, etc.) Check the POUT sensor harness, and check installation of the fusing unit. Use SIM14 to clear the self diag display.
L1	00	Content	Scanner feed trouble
		Detail	Though the specified steps of motor pulses are outputted, the mirror home position sensor remains ON.
		Cause	Mirror unit abnormality The scanner wire is disconnected. The origin detection sensor abnormality Mirror motor harness abnormality
		Check and remedy	Use SIM 1-1 to check the mirror reciprocating operations. <b>When the mirror does not feed.</b> Check for disconnection of the scanner wire. Check the harness and the connector between the mirror motor and the MCU PWB. Replace the mirror unit. Replace the MCU PWB. <b>When the mirror does feed.</b> Use SIM 1-2 to check the mirror home position sensor.
L3	00	Content	Scanner return trouble
		Detail	Though the specified steps of motor pulses are outputted, the mirror home position sensor does not turn ON.
		Cause	Mirror unit abnormality Scanner wire disconnection Origin detection sensor abnormality Mirror motor harness abnormality
		Check and remedy	Use SIM 1-1 to check the mirror reciprocating operations. <b>When the mirror does not return.</b> Check for disconnection of the scanner wire. Check the harness and the connector between the mirror motor and the MCU PWB. Replace the mirror unit. Replace the MCU PWB. <b>When the mirror does feed.</b> Use SIM 1-2 to check the mirror home position sensor.

Main code	Sub code		Details of trouble
L4	01	Content	Main motor lock detection
		Detail	The main motor does not rotate. After rotation of the main motor, the motor lock signal is detected for 1 sec or more. During rotation of the main motor, the motor lock signal is detected for 1 sec. When the main motor is stopped, the motor lock signal is not detected for 5sec or more. (Though the motor is stationary, it is judged as stable rotation.)
		Cause	Main motor unit abnormality Improper connection or disconnection the main motor and the harness. MCU PWB abnormality
		Check and remedy	Use SIM 25-01 to check the main motor operations. Check connection of the main motor harness/connector. Replace the main motor. Replace the MCU PWB.
	31	Content	Fusing fan lock detection
		Detail	The fusing fan does not rotate. Sampling is performed in 50msec interval, and the normal signal cannot be detected 5 times continuously in 1 sec.
		Cause	Fan trouble or harness contact trouble and disconnection
		Check and remedy	Use SIM05-02 to check the operations of the fusing fan motor. Heck connection of the fan harness and the connector. Replace the fan. Replace the MCU PWB.
	32	Content	PSFAN lock detection
		Detail	The PSFAN does not rotate. Sampling is performed in 50msec interval, and the normal signal cannot be detected 5 times continuously in 1 sec.
		Cause	Fan trouble or harness contact trouble and disconnection
		Check and remedy	Check connection of the fan harness and the connector. Replace the fan. Replace the MCU PWB.
L6	10	Content	Polygon motor lock detection
		Detail	The polygon motor does not rotate After shifting the polygon motor, the motor lock signal is detected for 20sec or more. During rotation of the polygon motor, the motor lock signal is detected for 1sec.
		Cause	Polygon motor unit abnormality Improper connection or disconnection of the polygon motor and the harness. MCU PWB abnormality
		Check and remedy	Use SIM 61-3 to check the polygon motor operations. Check connection of the polygon motor harness/connector. Replace the polygon motor.. Replace the MCU PWB.

Main code	Sub code		Details of trouble
U2	04	Content	EEPROM read/write error (Serial communication error)
		Detail	EEPROM access process error
		Cause	EEPROM abnormality
		Check and remedy	Check that the EEPROM is properly set. Use SIM 16 to cancel the trouble. Replace the MCU PWB.
	11	Content	Counter check sum error (EEPROM)
		Detail	Check sum error of the counter area in the EEPROM
		Cause	EEPROM abnormality
		Check and remedy	Check that the EEPROM is properly set. Use SIM 16 to cancel the trouble. Replace the MCU PWB.
	12	Content	Adjustment value check sum error (EEPROM)
		Detail	Check sum error of the adjustment value area in the EEPROM
		Cause	EEPROM abnormality
		Check and remedy	Check that the EEPROM is properly set. Use SIM 16 to cancel the trouble. Replace the MCU PWB.
CH ON	None	Content	Side door open
		Detail	The side door is open.
		Cause	Side door sensor abnormality MCU PWB abnormality
		Check and remedy	Check that all the side doors are closed. Replace the MCU PWB.
CH Blink	None	Content	Developing cartridge not installed
		Detail	The developing cartridge is not installed. Communication with the CRUM cannot be made in initial check of the CRUM.
		Cause	Developing unit disconnection MCU PWB abnormality CRUM chip abnormality
		Check and remedy	Check installation of the developing unit. Replace the MCU PWB.

# [9] MAINTENANCE

## 1. Maintenance table

X:Check(Clean, adjust, or replace when required.) O:Clean ▲:Replace △:Adjust ☆:Lubricate

Unit name	Part name	When calling	50K	100K	150K	200K	250K	300K	Remark
Drum peripheral	OPC drum	-	▲	▲	▲	▲	▲	▲	
	Cleaning blade	-	▲	▲	▲	▲	▲	▲	
	Side seal F/R	X	X	X	X	X	X	X	
	MC unit	X	▲	▲	▲	▲	▲	▲	
	(MC charging electrode)	-	(▲)	(▲)	(▲)	(▲)	(▲)	(▲)	Exchange if necessary
	(MC grid)	-	(▲)	(▲)	(▲)	(▲)	(▲)	(▲)	Exchange if necessary
	(MC case)	-	(▲)	(▲)	(▲)	(▲)	(▲)	(▲)	Exchange if necessary
	Transfer wire	O	O	O	O	O	O	O	
	Transfer paper guide	O	O	O	O	O	O	O	
	MC guide seal (Cleaning blade)	-	▲	▲	▲	▲	▲	▲	
	Drum fixing plate B	X	▲	▲	▲	▲	▲	▲	
	Separation pawl	X	▲	▲	▲	▲	▲	▲	
	Star ring N2								
	Star ring φ 5								
	Pawl holder PAN								
Process frame unit	X	X	X	▲	X	X	▲		
Discharge holder	O	O	O	O	O	O	O		
Developing section	Developer	X	▲	▲	▲	▲	▲	▲	
	DV seal	X	X	X	▲	X	X	▲	
	Toner density sensor	X	X	X	X	X	X	X	Check the sensor head surface.
	DV side seal F/R	X	X	X	X	X	X	X	
Optical section	Reflector	O	O	O	O	O	O	O	
	Mirrors	-	O	O	O	O	O	O	
	Pulley	-	X	X	X	X	X	X	
	CCD Lens	-	O	O	O	O	O	O	
	Table glass	O	O	O	O	O	O	O	
	White Plate	O	O	O	O	O	O	O	
	Drive wire	-	X	X	X	X	X	X	
	Rail	-	X ☆	X ☆	X ☆	X ☆	X ☆	X ☆	
	OC	O	O	O	O	O	O	O	
LSU	Dust-proof glass	O	O	O	O	O	O	O	
Paper feed section	Manual feed take-up roller	O	O	O	O	O	O	O	*2 Alcohol cleaning
	Transport rollers	O	O	O	O	O	O	O	*2 Alcohol cleaning
	Spring clutch	-	O ☆	O ☆	O ☆	O ☆	O ☆	O ☆	
	Electromagnetic clutches	-	X	X	X	X	X	X	
Fusing section	Upper heat roller	X	O	O	▲	O	O	▲	
	Pressure roller	X	O	O	O	O	O	O	
	Pressure roller bearing	-	X	X	O ☆	O ☆	O ☆	O ☆	
	Upper separation pawl	X	X	X	O	O	O	O	
	Lower separation pawl	X	X	X	O	O	O	O	
	Cleaning pad	X	X	X	▲	X	X	▲	
Drive section	Gears	-	X ☆	X ☆	X ☆	X ☆	X ☆	X ☆	
	Belts	-	X	X	O	O	O	O	
Paper exit section	VOC filter	-	▲	▲	▲	▲	▲	▲	*1
Document transport section	Pickup roller	O	O	O	O	O	O	O	*3
	Handling unit	X	X	X	X	X	X	X	*2
	Handling sheet	X	X	X	X	X	X	X	
	Paper feed roller	O	O	O	O	O	O	O	*3
	PS roller	O	O	O	O	O	O	O	
	Transport roller	X	X	X	X	X	X	X	
	Paper exit roller	X	X	X	X	X	X	X	
Cassette paper feed section	Paper feed roller	X	X	X	▲	X	X	▲	*2
	Handling unit	X	X	X	X	X	X	X	
	Handling sheet	X	X	X	▲	X	X	▲	*2

\*1: Recommendable replacement time:50K(A4, 6%print)

\*2: In maintenance cycle, after beginning to use each paper feed counter 100K, one year is a standard. Exchange when worn out.

\*3: Maintenance cycle is RSPF document FEED value 100K (Sim.22-8). Or, after it begins to use it, one year is a standard. When worn out, it exchanges it.

## 2. Maintenance display system

Toner	Life,	16K	
	Remaining quantity check *1	a. Press and hold the [Light] keys ([Light and Dark] keys) for more than 5 sec, and the machine will enter the user program mode. b. Press and hold the [%] key for more than 5 sec, and the remaining quantity will be displayed on the copy quantity display in one of the following levels: (Remaining quantity display levels: 100%, 75%, 50%, 25%, 10%, LO) c. Press the [Light] keys ([Light and Dark] keys) to cancel.	
	Remaining quantity	NEAR EMPTY About 10%	EMPTY
	LED	ON	Flash
	Machine	Operation allowed	Stop
Developer	Life	50K	
	LED	ON at 50K of the developer count	
	Machine	Selection is available between Not Stop and Stop by Service Simulation (SIM 26-37) Setup. (If Stop is selected, the LED will flash and stop at 50K.) * Default: Not Stop * Clear: SIM 42-1	
Maintenance	LED	Selection is available among 50K, 25K, 10K, 7.5K, 5K, and free (no lighting) with SIM 21-1. * Default: 50K * Clear: SIM 20-1	
	Machine	Not stop	

\*1: Installation of a new toner cartridge allows to display the remaining quantity.

## 3. Note for replacement of consumable parts

### A. Toner cartridge

When a waste toner cartridge is removed from the machine, it must be put in a polyethylene bag to avoid scattering of toner.

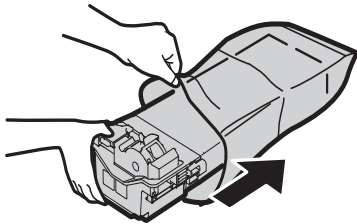

### B. DV cartridge

Do not shake or put up the developer cartridge. Otherwise developer may scatter.

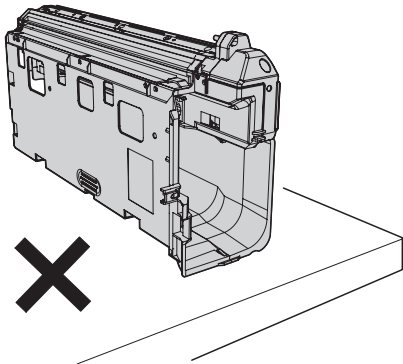

## C. DV seal attachment procedure

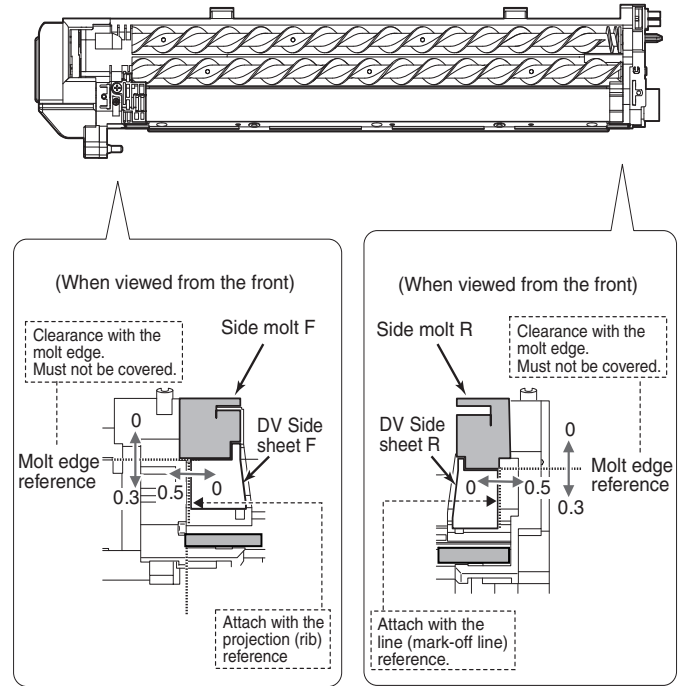

# [10] DISASSEMBLY AND ASSEMBLY

**WARNING** Before performing the disassembly procedure, be sure to remove the power cord to prevent against an electric shock.

No.	Item
1	High voltage section/Duplex transport section
2	Optical section
3	Fusing section
4	Paper exit section
5	MCU
6	Optical frame unit
7	LSU
8	Tray paper feed section/Paper transport section
9	Bypass tray section
10	Power section
11	Developing section
12	Process section
13	Others

## 1. High voltage section/Duplex transport section

No.	Content
A	Transfer charger unit
B	Charger wire
C	Duplex transport section

### A. Transfer charger unit

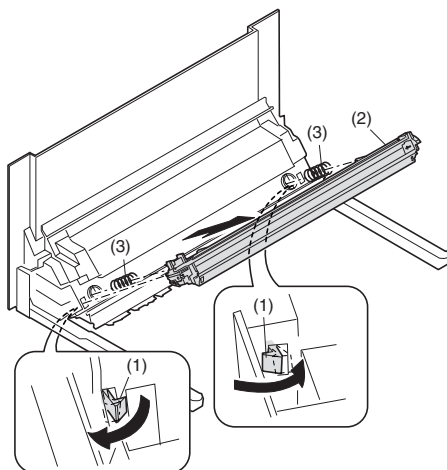
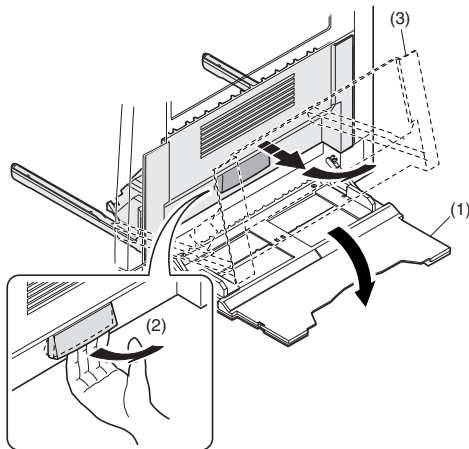

### B. Charger wire

Installation: The spring tip must be between two reference ribs.

- The charger wire must be free from twists or bending.
- Be sure to put the charger wire in the V groove.

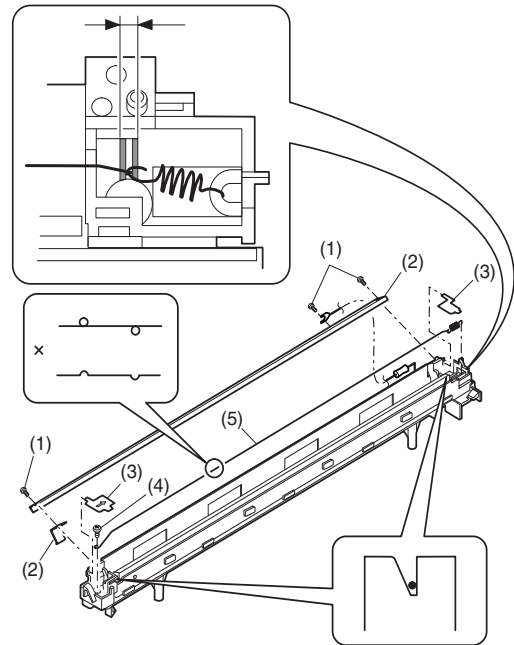

### C. Duplex transport section

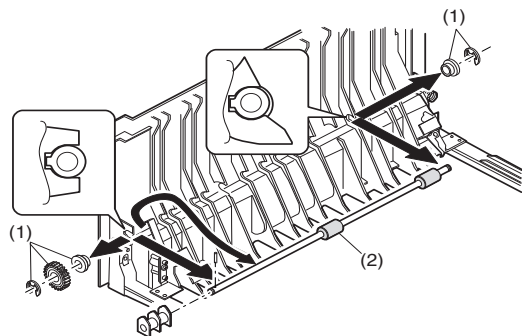
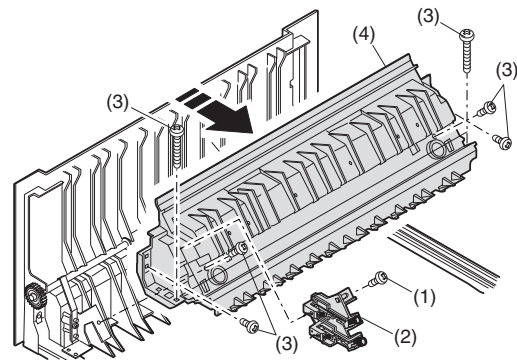

## 2. Optical section

Note: When disassembling or assembling the optical unit, be careful not to touch the mirror and the reflector.

No.	Content
A	Table glass
B	Copy lamp unit
C	Inverter PWB for copy lamp
D	Copy lamp
E	Lens unit
F	Wire

### A. Table glass

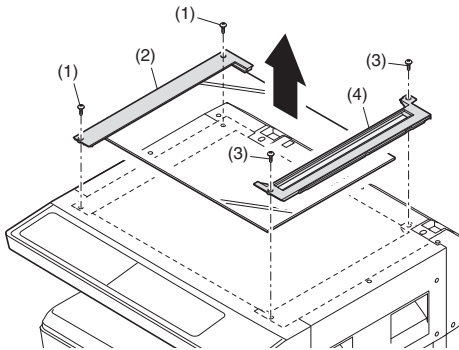

### B. Copy lamp unit

Disassembly: Be sure to put No. 2/3 mirror unit to the positioning plate (A).

Assembly: Put the notched surface of wire holder (3) downward, tighten temporarily, and install.

Adjustment: Main scanning direction distortion balance adjustment

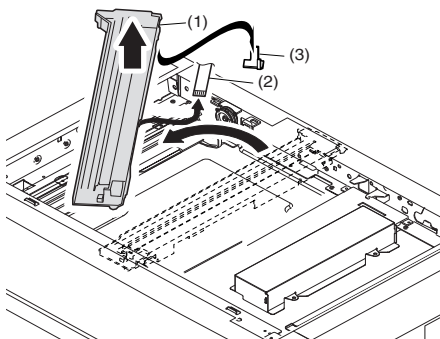
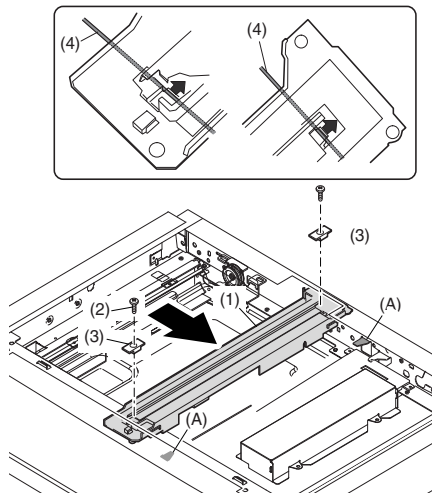

### C. Inverter PWB for copy lamp

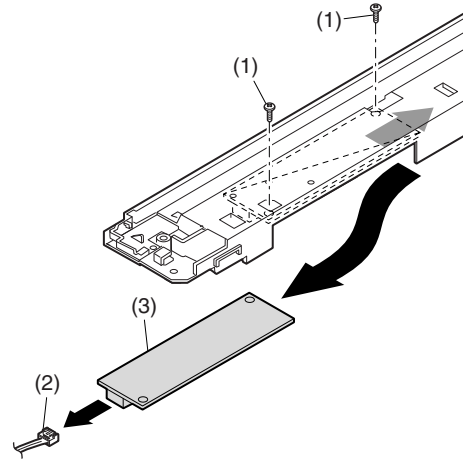
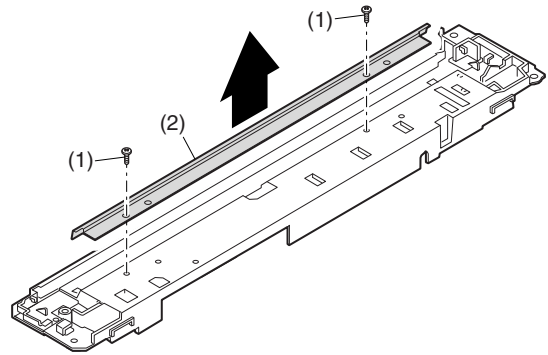

### D. Copy lamp

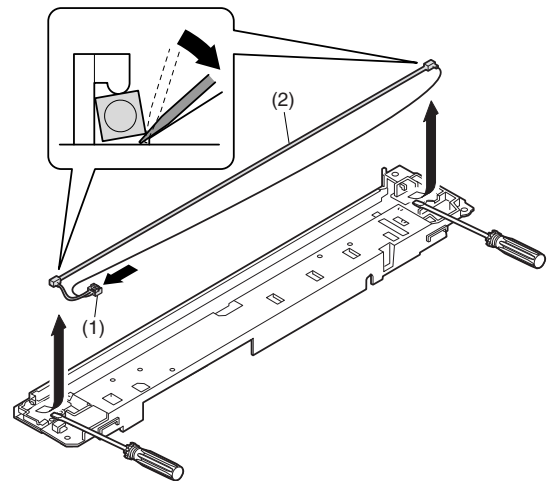

## E. Lens unit

Note: Do not remove screws which are not indicated in the figure. If the height of the base plate is changed, it cannot be adjusted in the market.

Note: The CCD/lens unit is factory-adjusted before shipping. Since these adjustments cannot be performed in the market. Never touch the screws other than screw 2) of the CCD/lens unit.

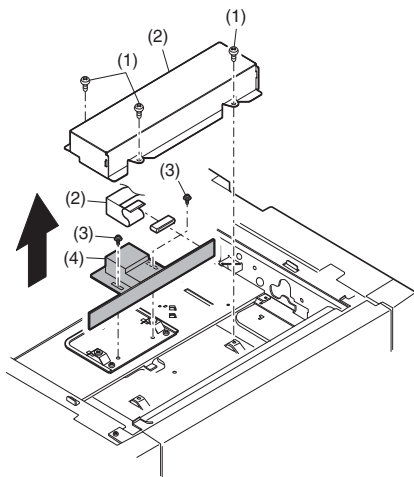

### Lens unit attachment

- <1> Remove the document table glass.
- <2> Remove the dark box cover.
- <3> To prevent against shift of the CCD unit optical axis, mark the CCD unit base as shown below.

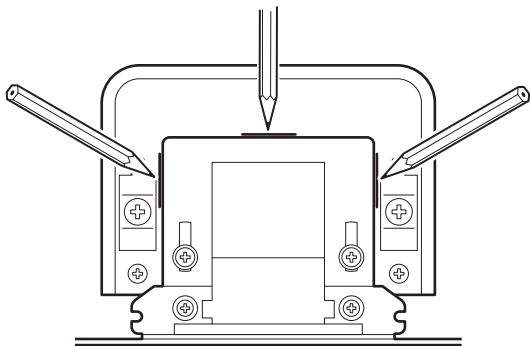

Note: This procedure must be executed also when the CCD unit is replaced.

<4> Loosen the CCD unit fixing screws.

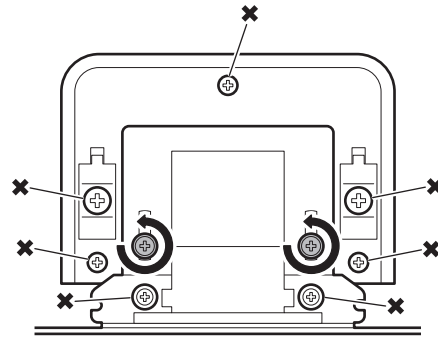

Note: Never loosen the screws marked with X.

If any one of these screws is loosened, the position and the angle of the CCD unit base may be changed to cause a problem, which cannot be adjusted in the market. In that case, the whole scanner unit must be replaced.

<5> Slide the CCD unit in the arrow direction (CCD sub scanning direction) to change the installing position.

When the copy image is longer than the original scale, shift the CCD unit in the direction B. When the copy image is shorter than the original scale, shift the CCD unit in the direction A.

One scale of mark-off line corresponds to 0.2%.

At that time, fix the CCD unit so that it is in parallel with the scale on the front and the rear side of the CCD unit base.

Note: Fix the CCD unit so that it is in parallel with the line marked in procedure <3>.

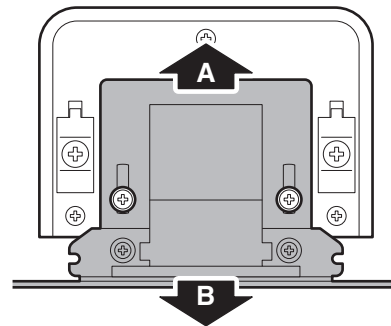

<6> Make a copy and check the copy magnification ratio again.

If the copy magnification ratio is not in the range of  $100 \pm 1\%$ , repeat the procedures of <3> - <5> until the condition is satisfied.

## F. Wire

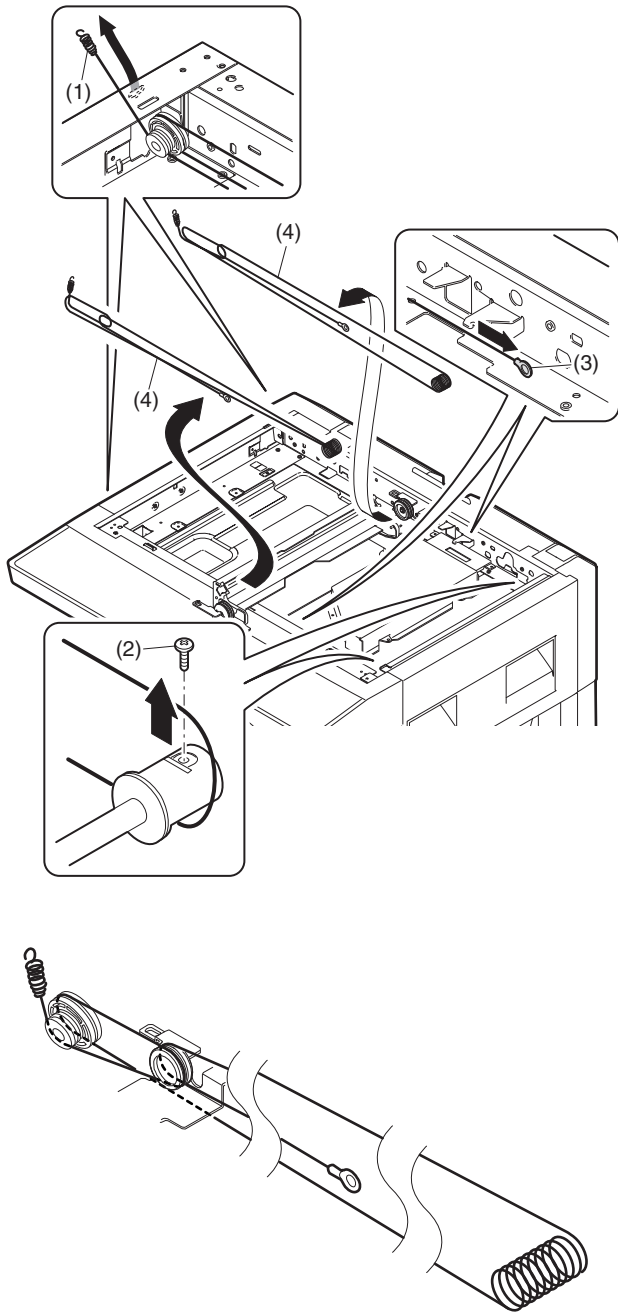

## 3. Fusing section

No.	Contents
A	Fusing unit
B	Thermostat
C	Thermistor
D	Heater lamp
E	Upper heat roller
F	Separation pawl
G	Lower heat roller
H	Separation pawl

### A. Fusing unit removal

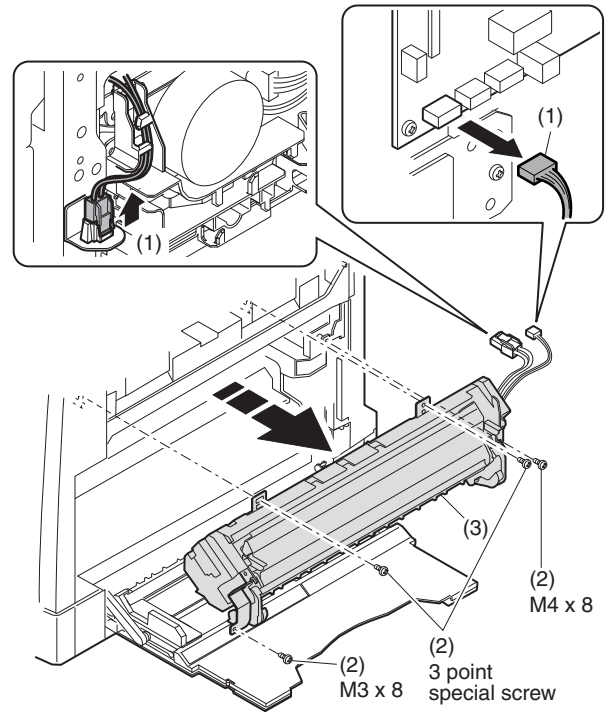

### B. Thermostat

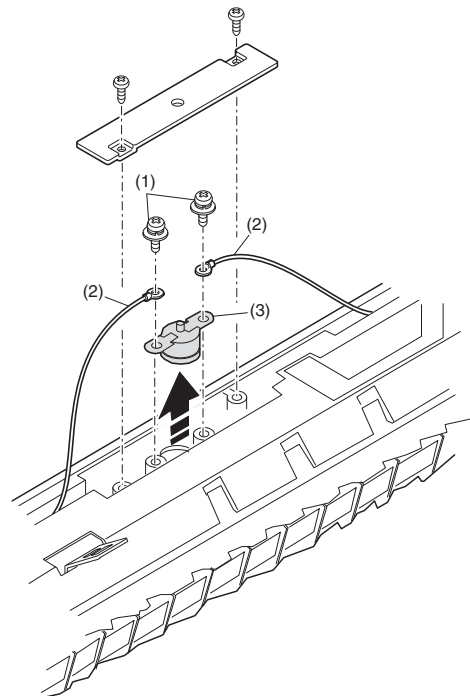

### C. Thermistor

Installation: Install in direction that the sponge side (A) of the thermistor comes in contact with heat roller.

Check that the thermistor is in contact with the upper heat roller.

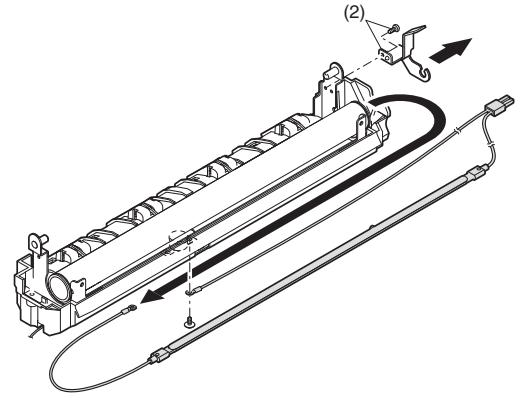
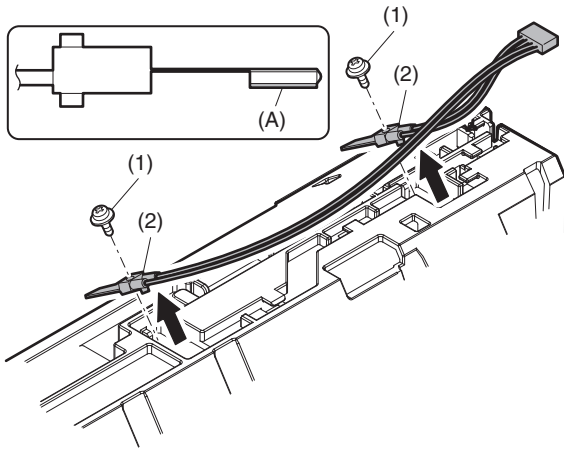

Assembly: Put the fusing harness (A) on the heater lamp (B) as shown in the figure and fix them together. Place the fusing harness inside the rib (C).

### D. Heater lamp

Assembly: Insert the spring (A) into the hole (B) in the fusing frame.

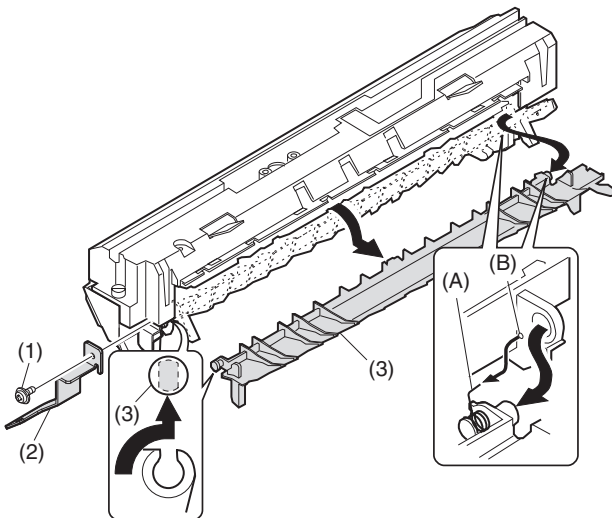

### E. Upper heat roller

Disassembly: There are three pawls on the fusing cover. Remove the screws and slide the fusing cover to the right to remove. The heater lamp is fixed on the fusing cover with a screw. Slide the fusing cover to the front and remove the screw, then remove the heater lamp.

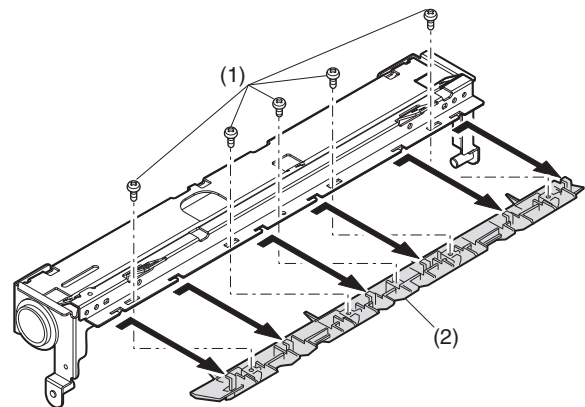
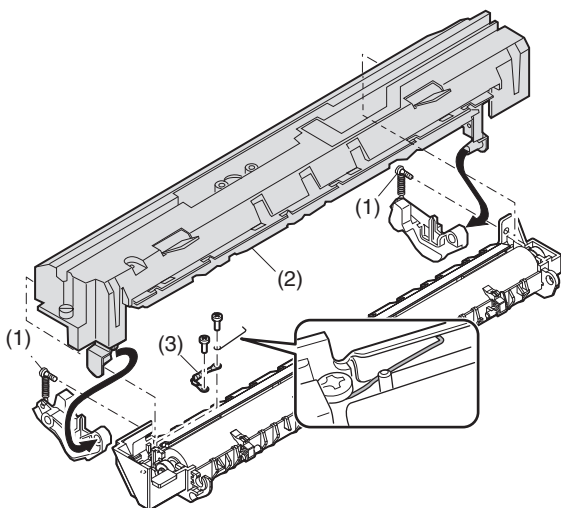
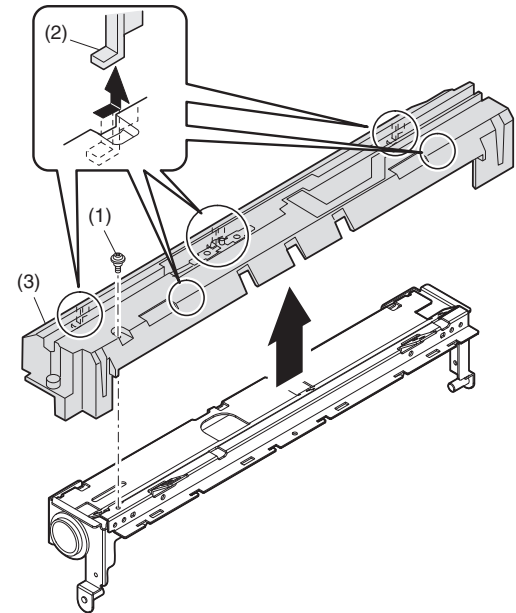

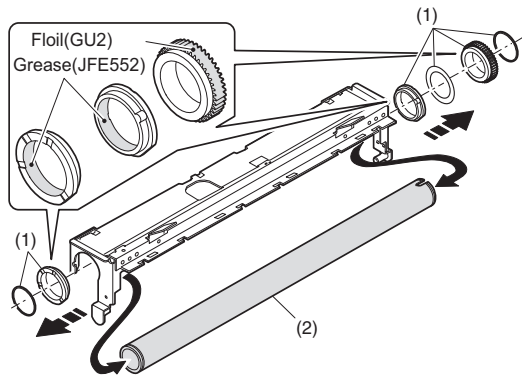

Note: It is grease (JFE552) application on a fusing frame metal plate part.  
(Degree to thinly)

### F. Separation pawl

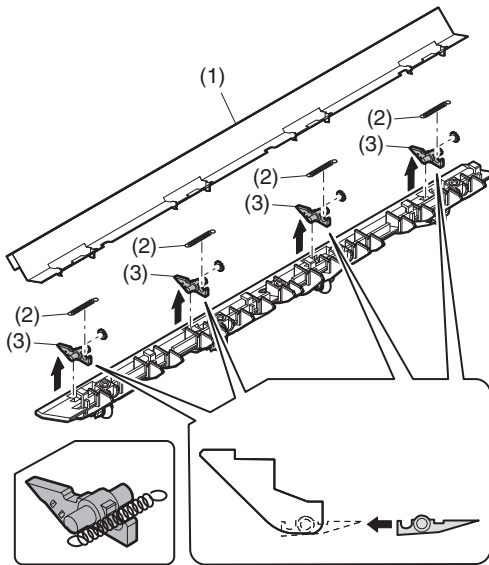

### G. Lower heat roller

Assembly: When assembling the fusing front paper guide (3), temporarily fix the paper guide fixing plate with the screw so that the paper guide fixing plate (2) is in contact with the fusing lower frame bottom (A). Lower the fusing front paper guide to the bottom of the adjustment width, and tighten the screw firmly.

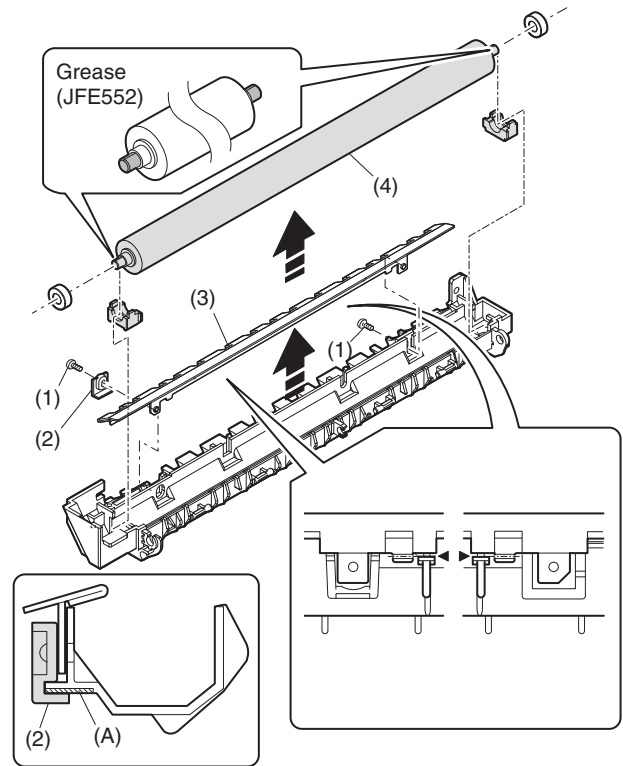

Note: I apply grease (JFE552) to a fusing lower frame, lib.

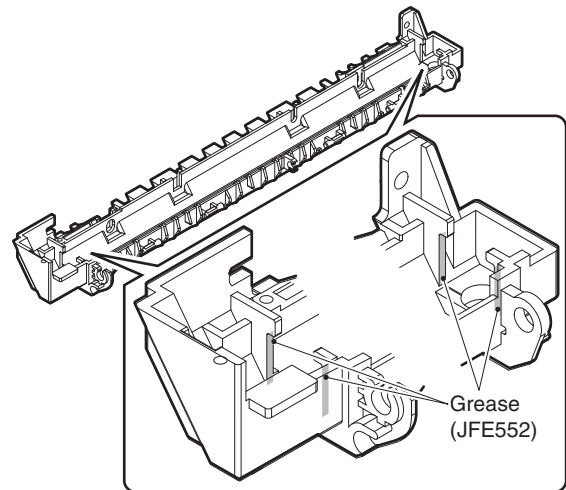

## H. Separation pawl

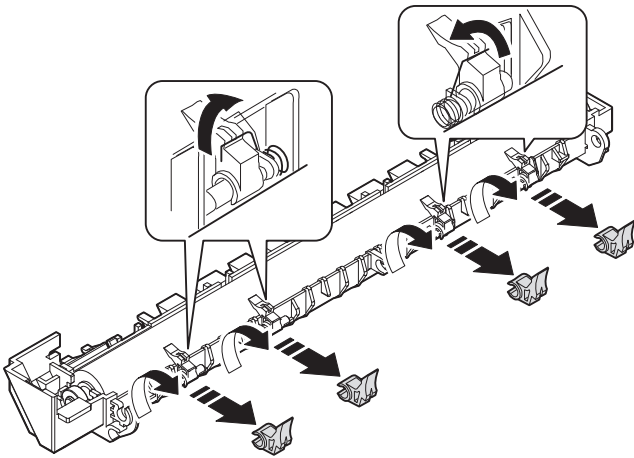

## B. Cooling fan (S model (Simplex)/N model (Duplex))

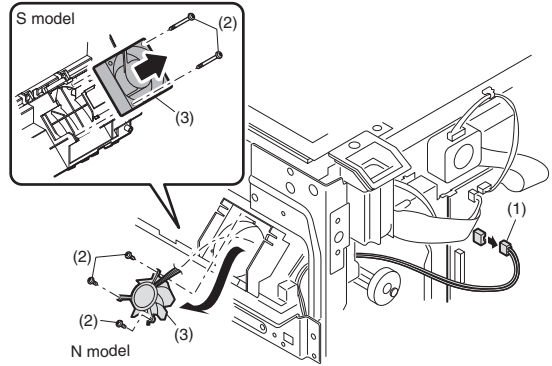

## 4. Paper exit section

No.	Content
A	Ozone filter
B	Cooling fan (S model (Simplex)/N model (Duplex))
C	Paper exit unit
D	Paper exit sensor / duplex sensor
E	Transport roller
F	Paper exit roller

## C. Paper exit unit

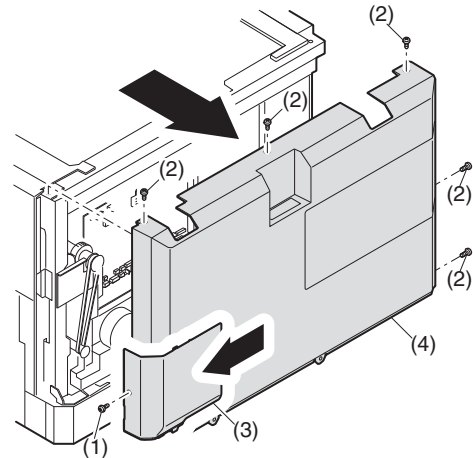

## A. Ozone filter

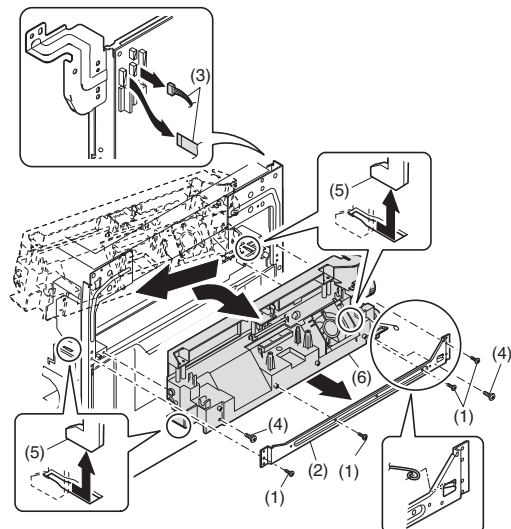
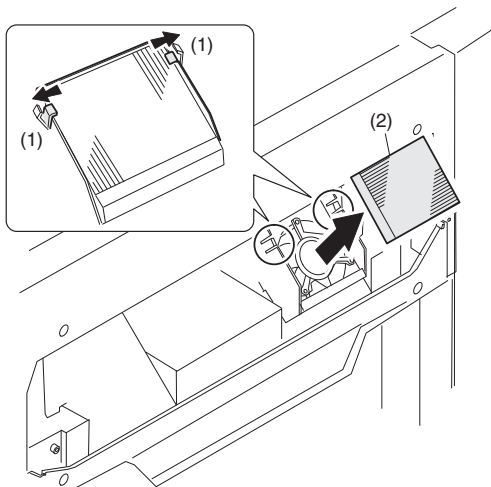
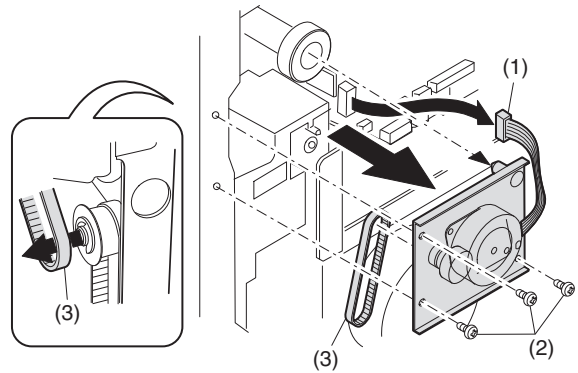
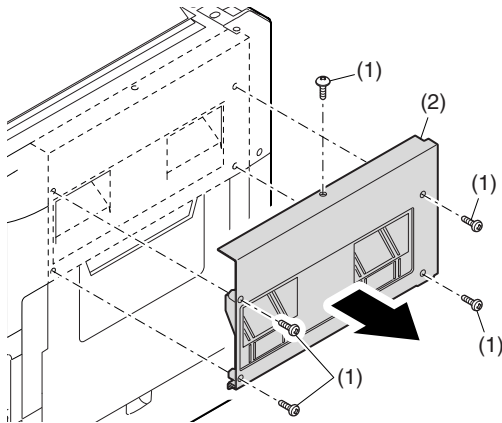

## D. Paper exit sensor / duplex sensor

(A) Exit sensor

(B) Duplex sensor

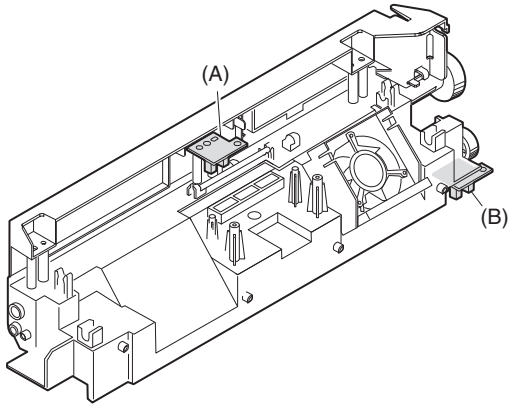

## E. Transport roller

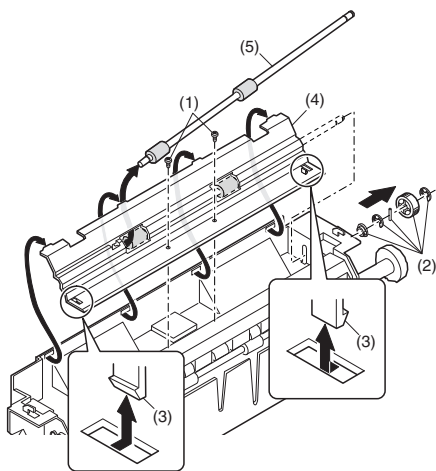
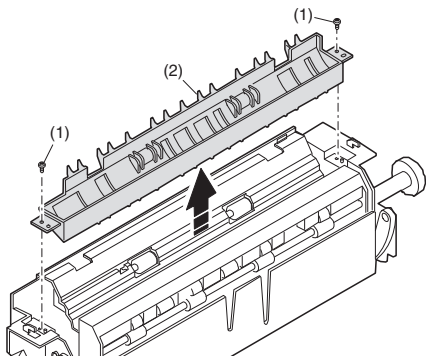

## F. Paper exit roller

Assembly: Insert the spring pin so that the waveform (A) of the spring pin faces in the longitudinal direction of the paper exit drive gear long hole (B). Be sure to insert two ribs (C) into the groove (D).

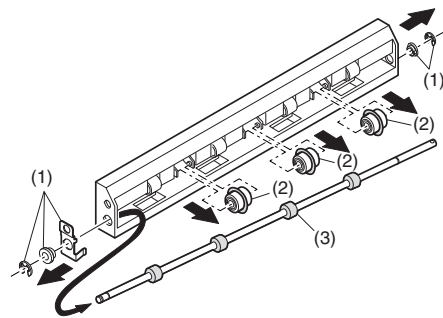
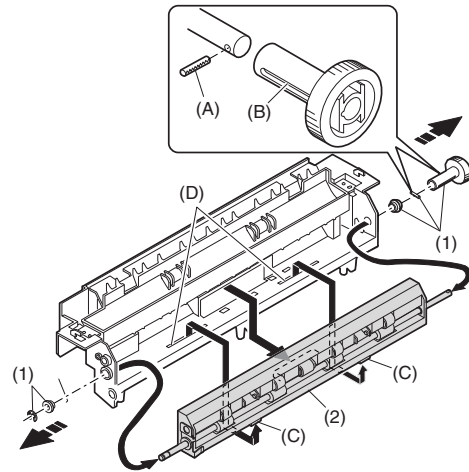

## 5. MCU/NIC

No.	Content
A	MCU disassembly
B	NIC disassembly

### A. MCU disassembly

Disassembly: The connector, the harness, and the screw are removed.

Note: When replacing the MCU PWB, be sure to replace the EEPROM of the MCU PWB to be replaced.

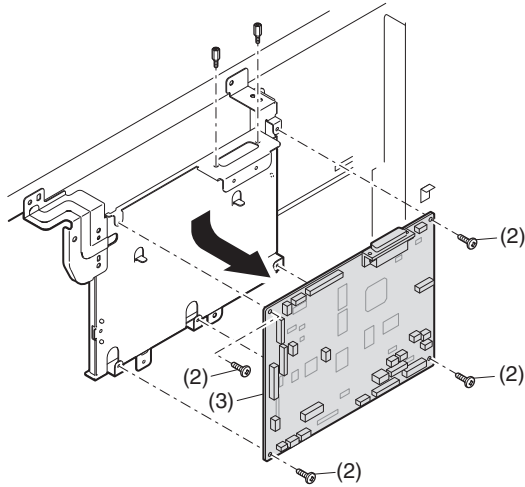

### B. NIC disassembly

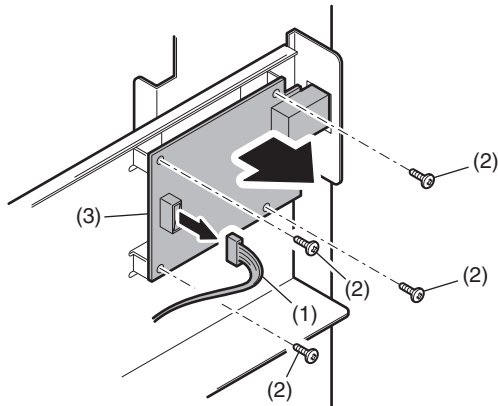

## 6. Optical frame unit

No.	Content
A	Optical frame unit

### A. Optical frame unit

Installation: Install the optical unit in the sequence shown above.

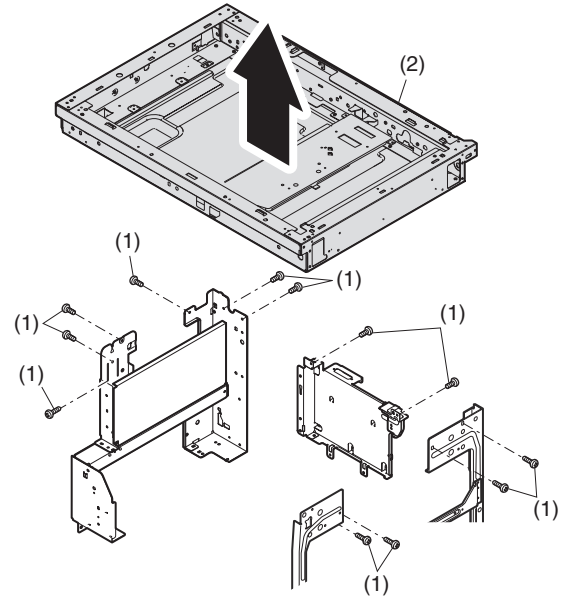

## 7. LSU

No.	Content
A	LSU unit

### A. LSU unit

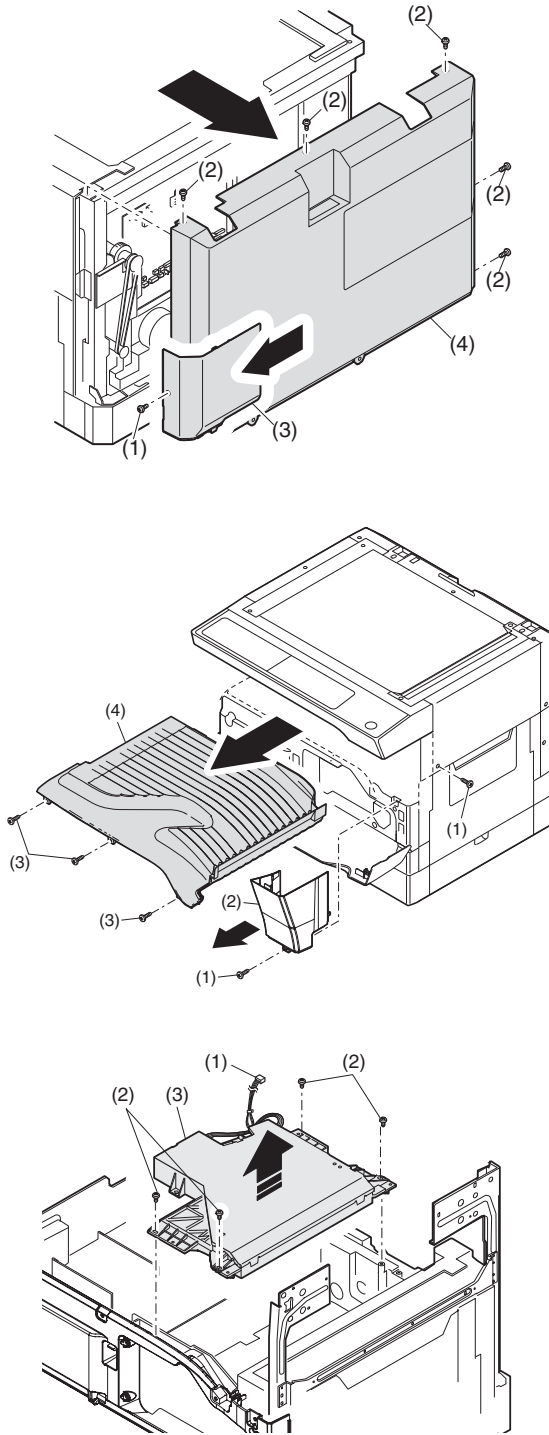

Note: Do not disassemble the LSU.

Note: When replacing the LSU, be careful not to touch the dust-shield glass.

Note: Turn OFF the machine power, and disconnect the power plug from the power outlet.

Adjustment:

- Image lead edge position adjustment
- Image left edge position adjustment
- Paper off-center adjustment

## 8. Tray paper feed section/Paper transport section

No.	Content
A	Middle frame unit
B	Drive unit
C	PS clutch/Resist roller
D	Paper feed clutch/Paper feed roller
E	Connection gear unit

### A. Middle frame unit

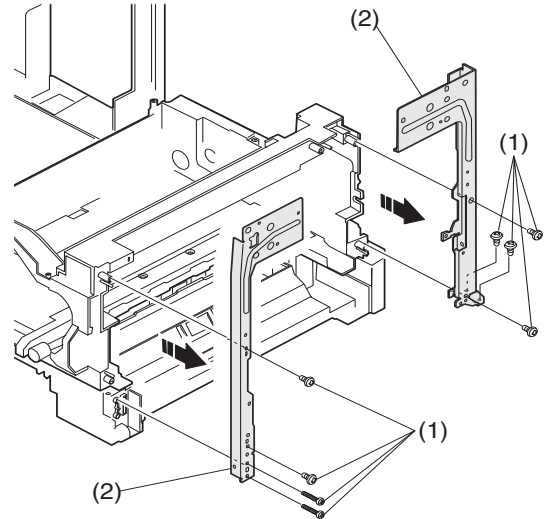

Assembly: Do not miss the door lock pawl.

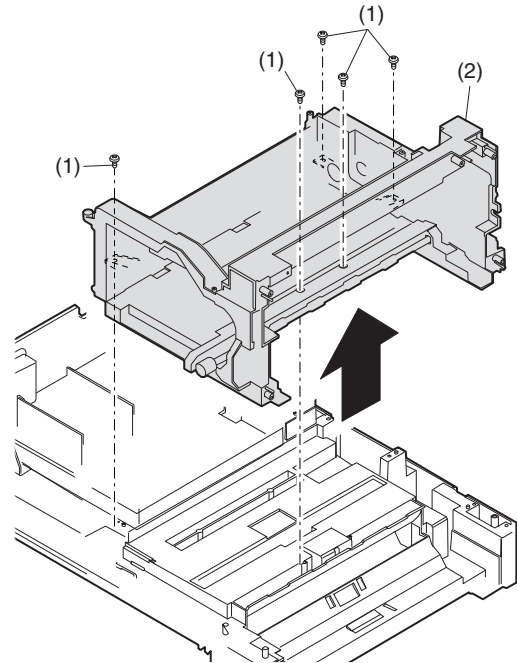

## B. Drive unit

Assembly: When assembling, be sure to check that the clutch rotation stopper is securely engaged in the frame.

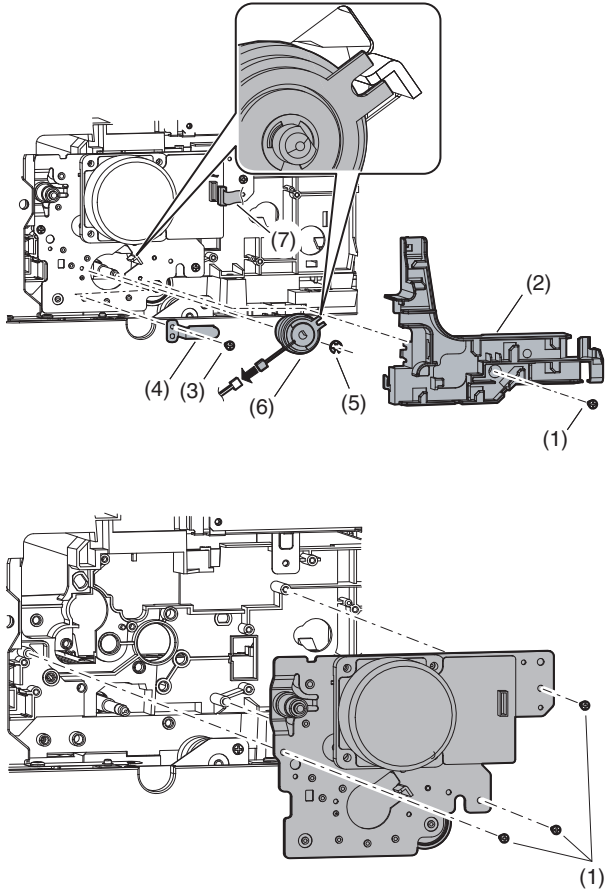

## D. Paper feed clutch/Paper feed roller

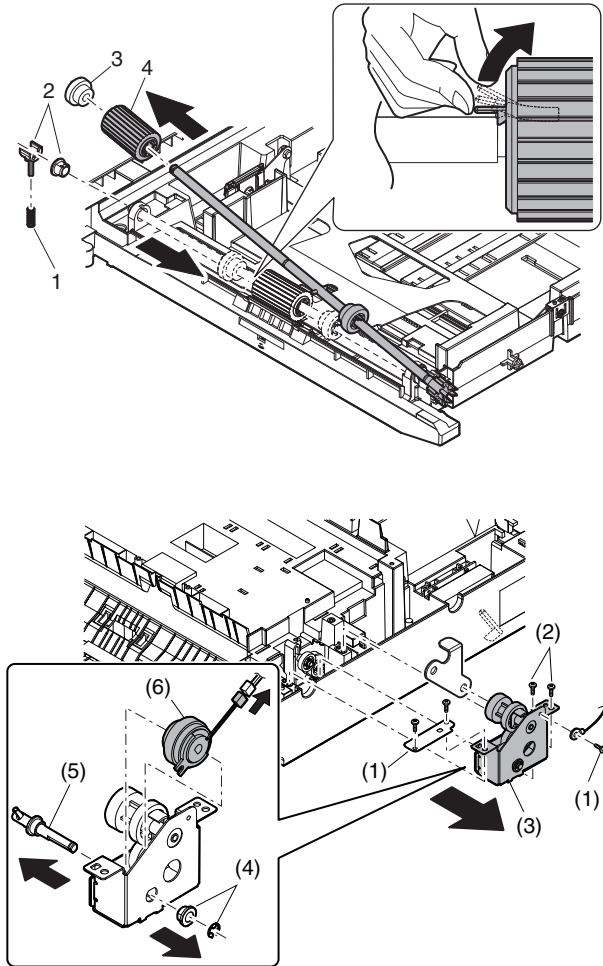

## C. PS clutch/Resist roller

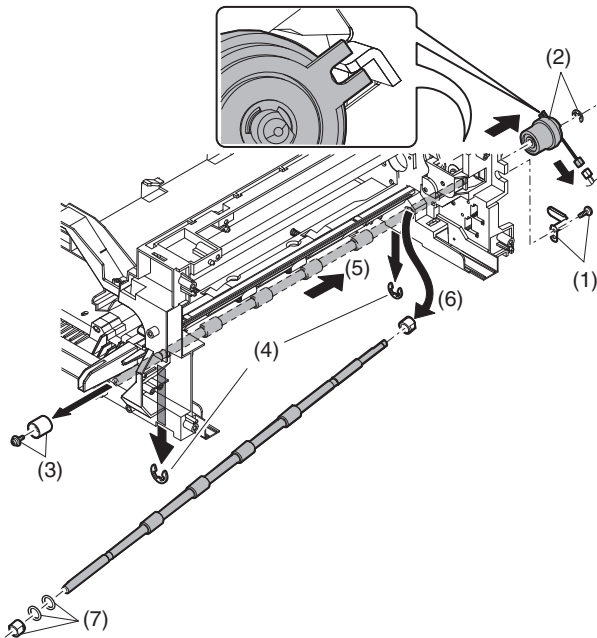

## E. Connection gear unit

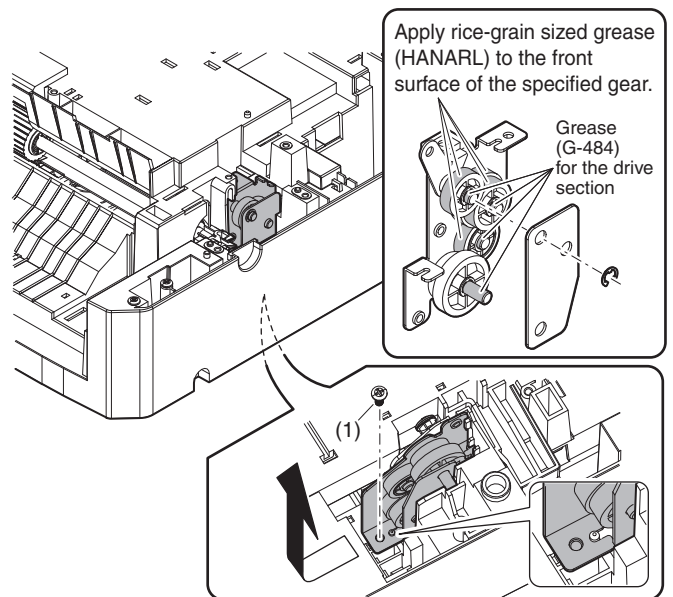

## 9. Bypass tray section

No.	Content
A	Bypass tray transport roller/Bypass tray paper feed roller
B	Bypass tray paper feed
C	Bypass tray solenoid
D	Bypass tray transport clutch
E	Pressure plate unit
F	Bypass tray paper feed clutch

### A. Bypass tray transport roller/Bypass tray paper feed roller

Note: Push the lever at the right edge of the multi frame cover to the right upper side and remove it.

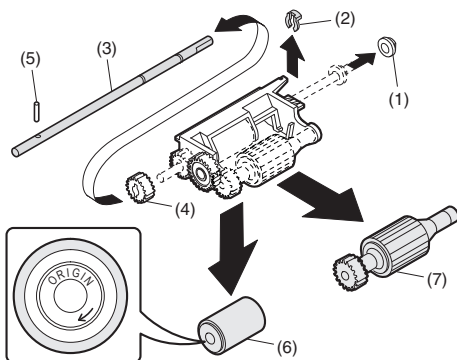
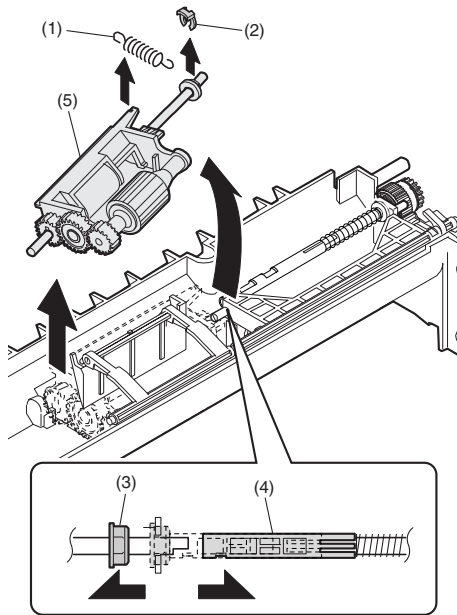
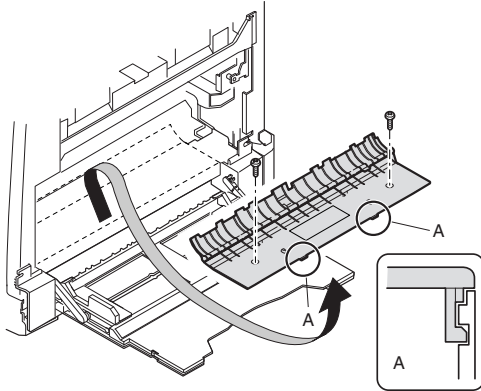

Installation: Be careful of the installing direction of the bypass tray transport roller (6)

### B. Bypass tray paper feed

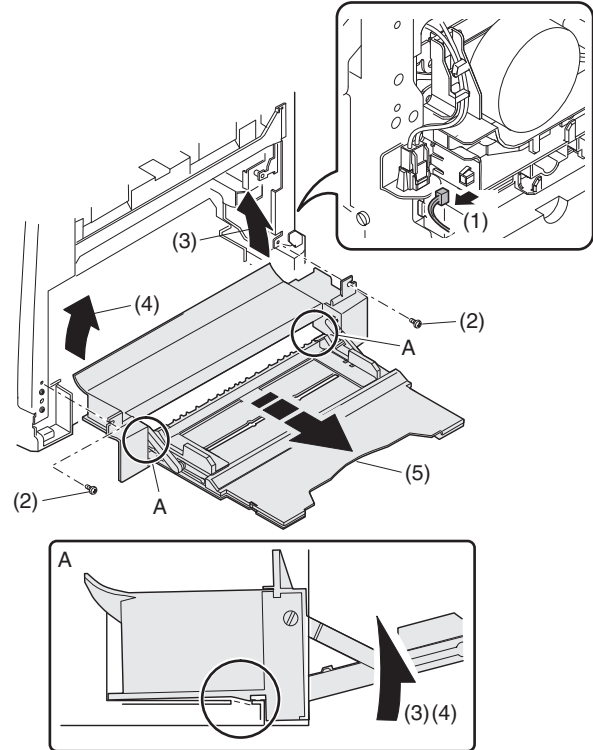

### C. Bypass tray solenoid

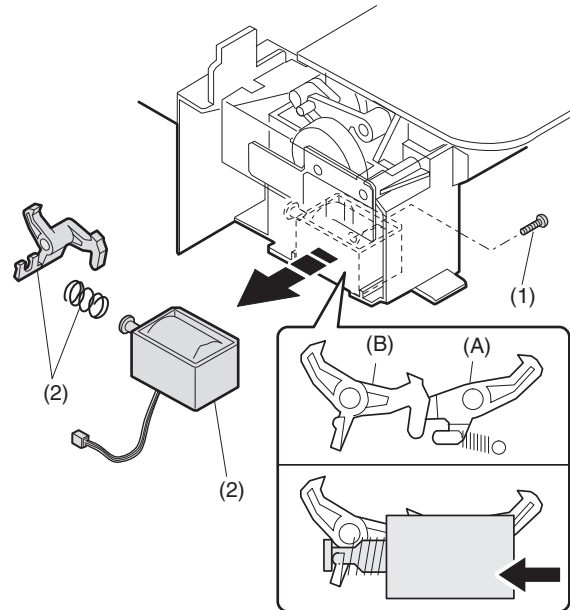

When installing the solenoid, shift it in the arrow direction and install.

### D. Bypass tray transport clutch

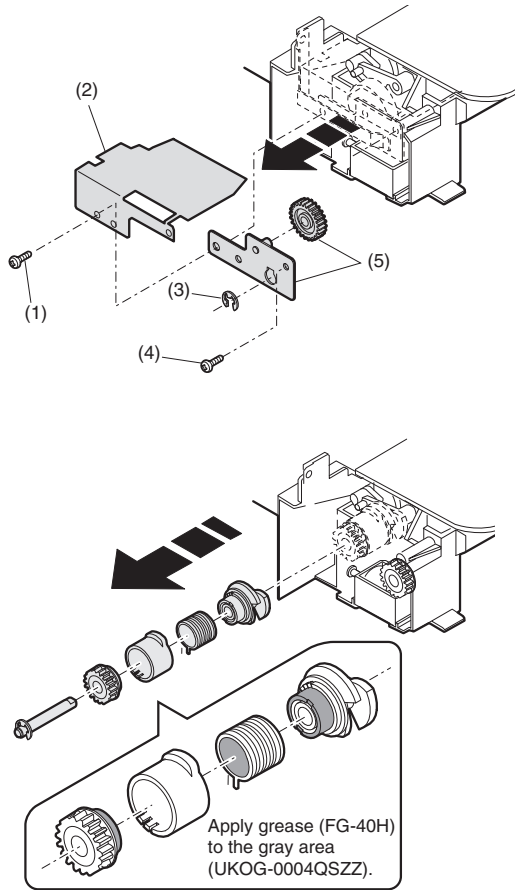

Apply grease (FG-40H) (UKOG-0004QSZZ).

### E. Pressure plate unit

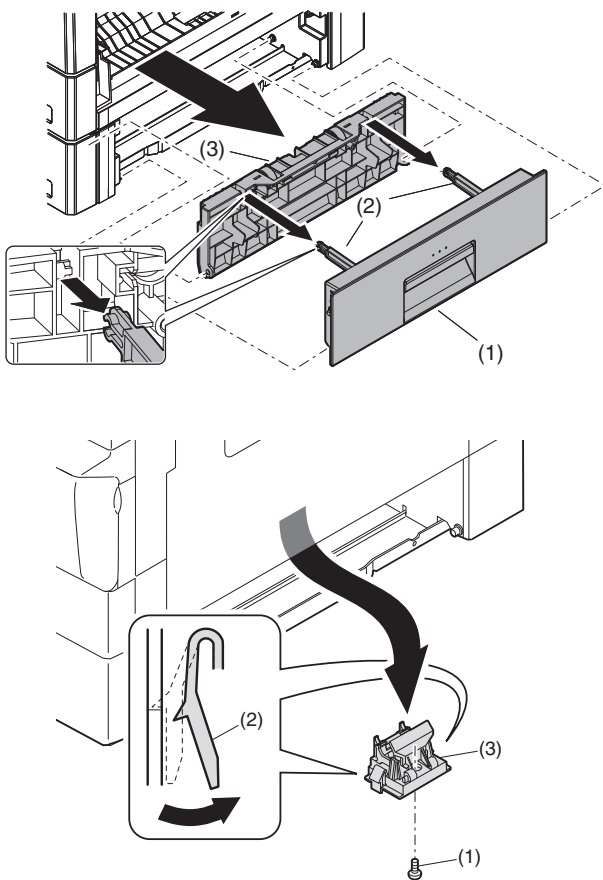

### F. Bypass tray paper feed clutch

Note: Push the lever at the right edge of the multi frame cover to the right upper side and remove it.

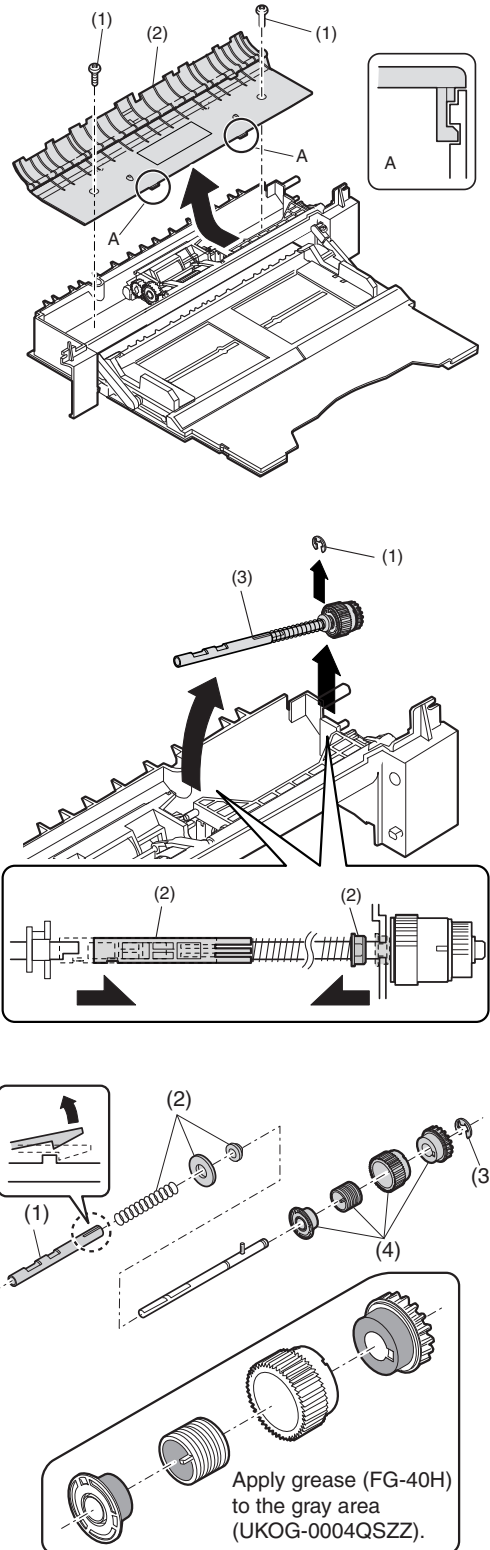

## 10. Power section

No.	Content
A	Power unit
B	High voltage P.W.B.
C	Power P.W.B.
D	Power switch

### A. Power unit

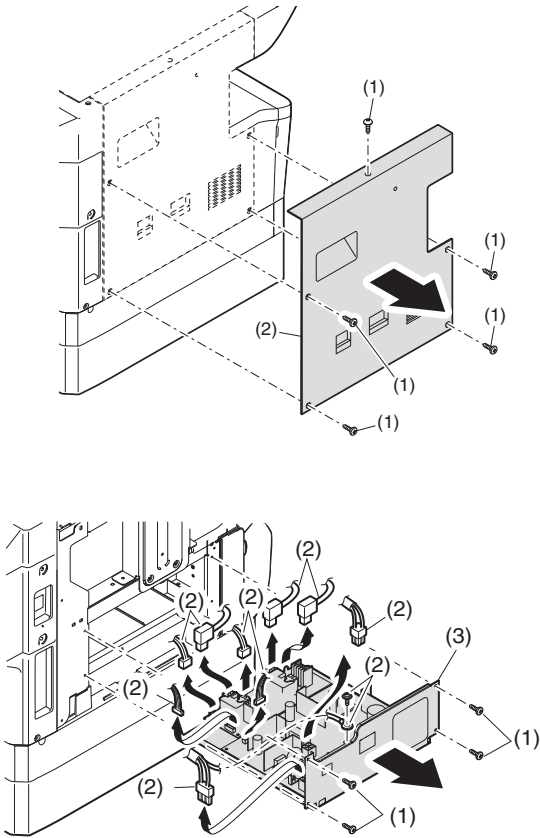

### B. High voltage P.W.B.

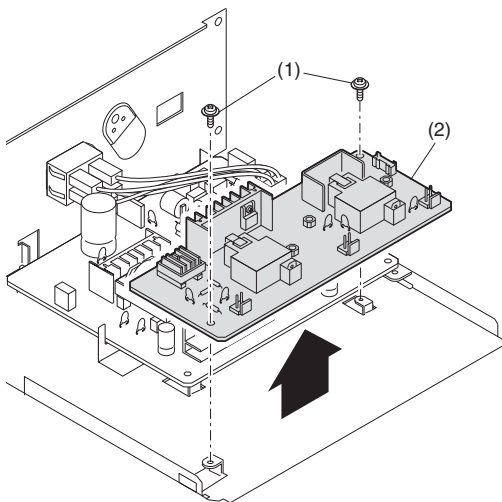

### C. Power P.W.B.

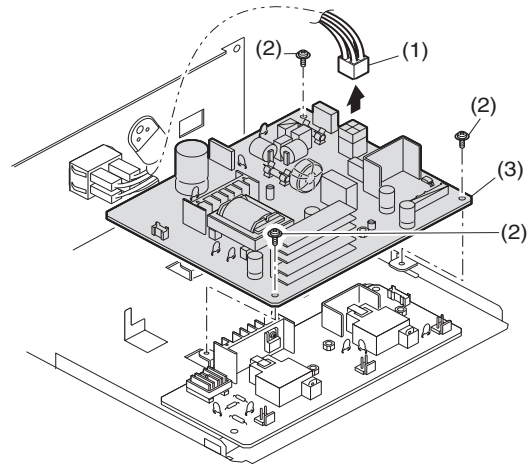

### D. Power switch

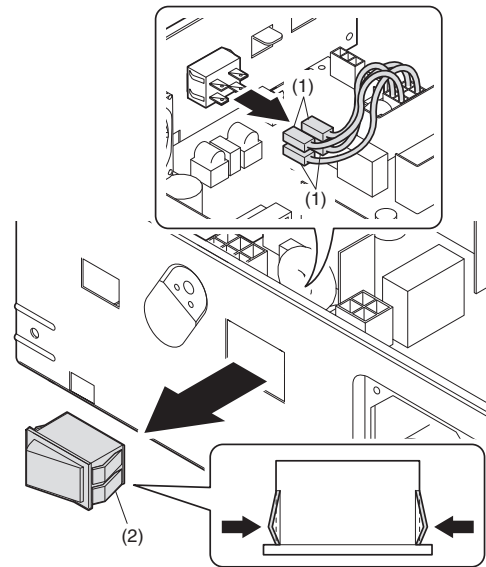

# 11. Developing section

No.	Contents
A	Developing box
B	Developing doctor
C	MG roller

## A. Developing box

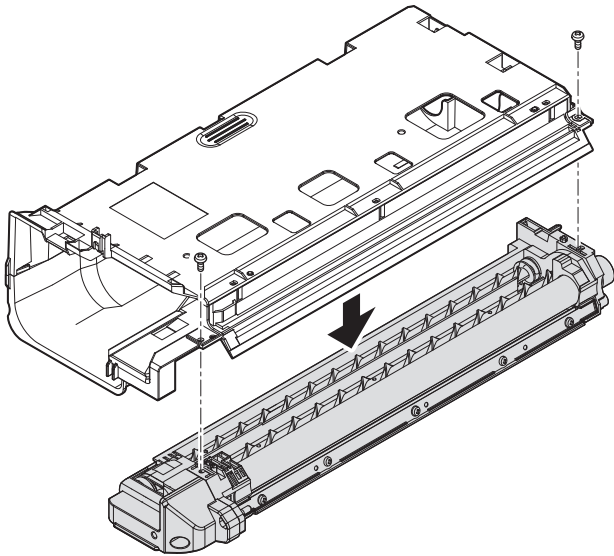

## B. Developing doctor

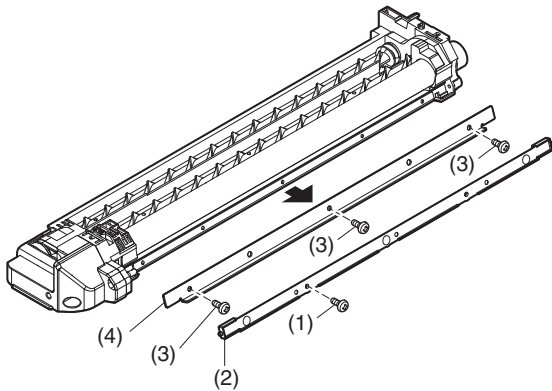

Adjustment: Developing doctor gap adjustment

## C. MG roller

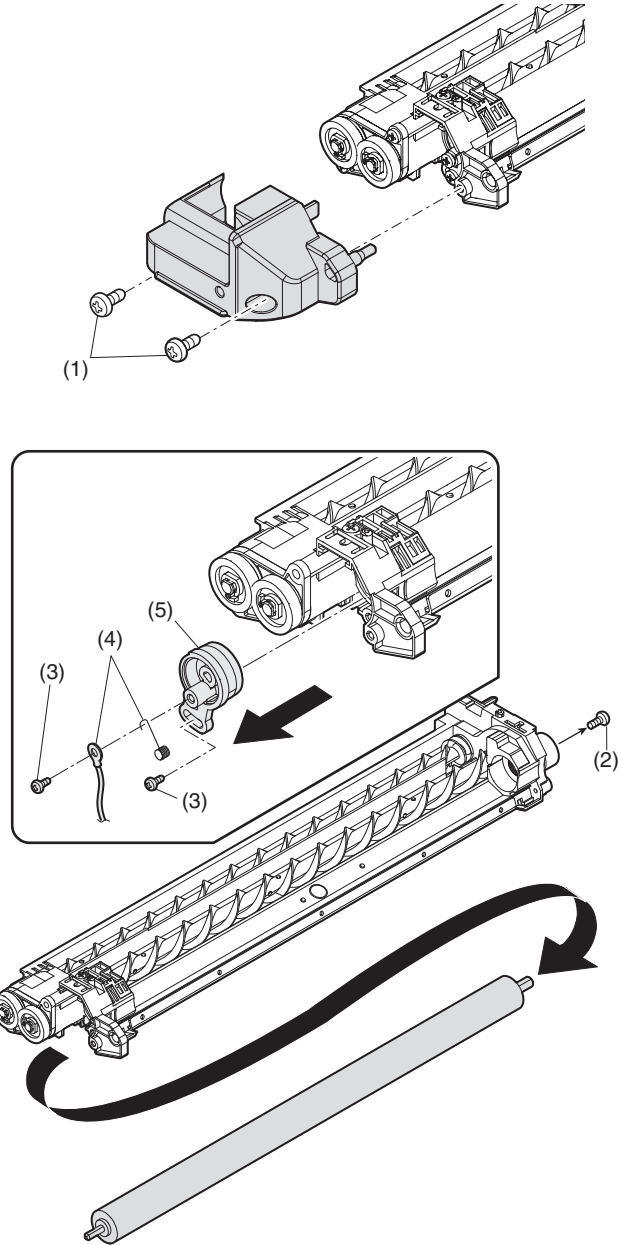

Adjustment: MG roller main pole position adjustment

Note: Attach it to fit with the attachment reference when replacing the DV blade.

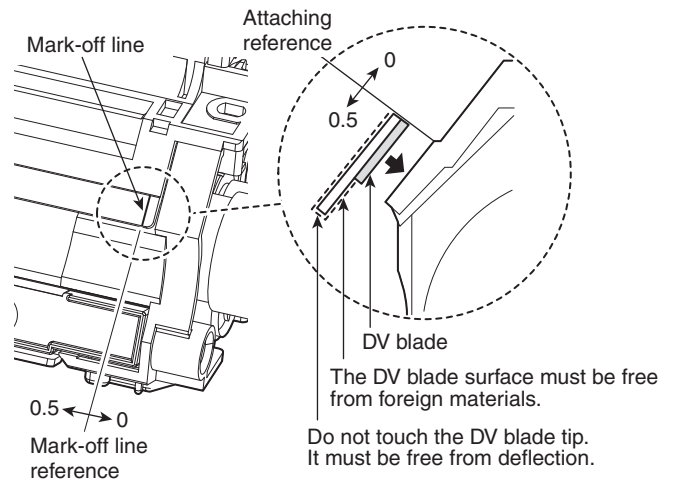

## 12.Process section

No.	Contents
A	Drum unit
B	Main charger unit
C	Cleaning blade

### A.Drum unit

When removing the drum, put the drum unit upside down to prevent waste toner from spilling.

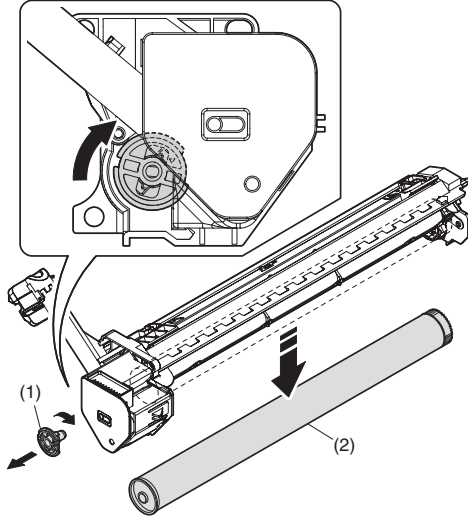

When the drum is replaced, be sure to replace the drum positioning boss with a new one, too.

### B. Main charger unit

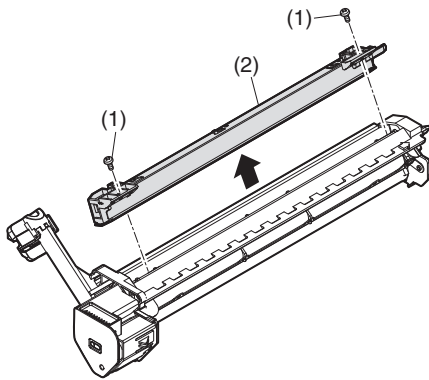

### C. Cleaning blade

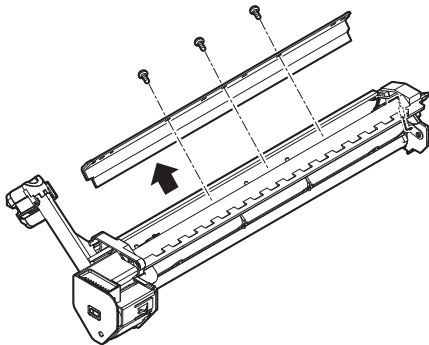

## 13.Others

No.	Contents
A	Operation P.W.B.
B	Tray interface P.W.B.
C	2nd tray paper entry sensor / Paper empty sensor
D	2nd tray transport clutch
E	2nd tray transport roller
F	2nd tray paper feed clutch
G	Main motor
H	Paper entry sensor
I	Paper empty sensor

### A. Operation P.W.B.

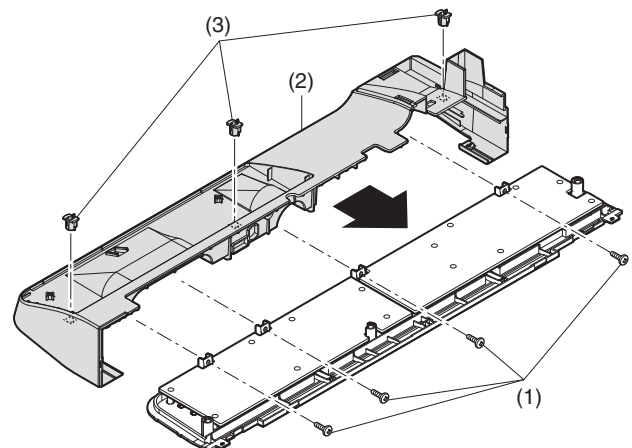
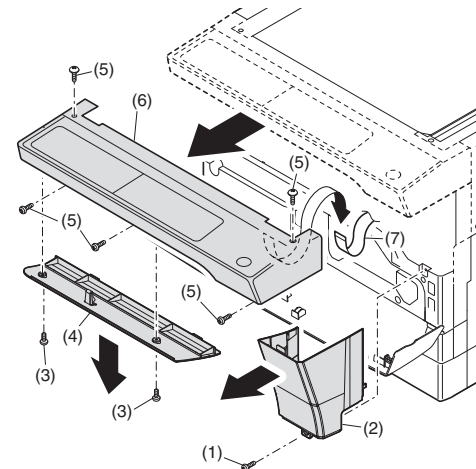
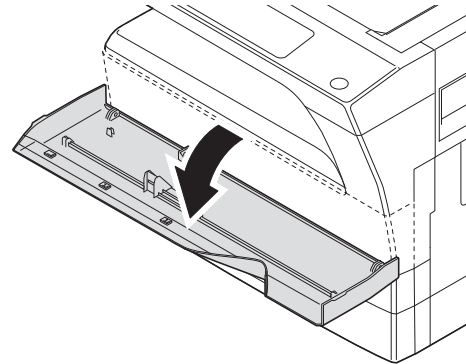

### C. 2nd tray paper entry sensor / Paper empty sensor

Disassembly: When the second paper feed unit is detached, the screw is removed, and the main body is lifted.

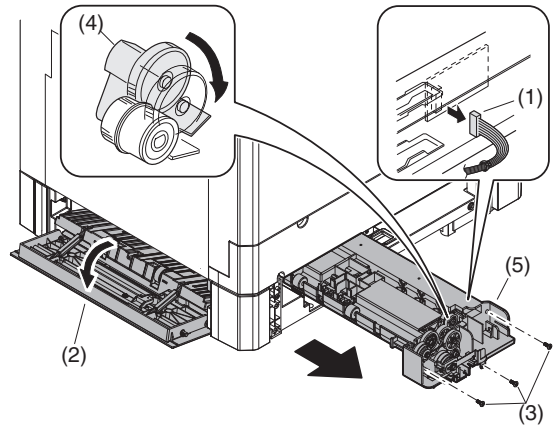
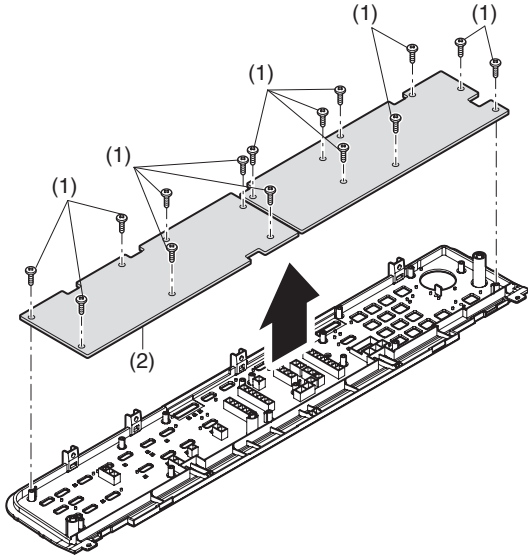

### B. Tray interface P.W.B.

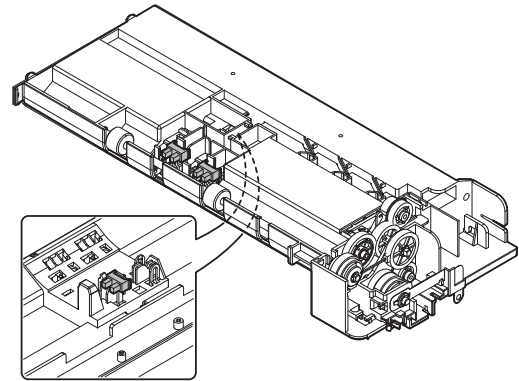
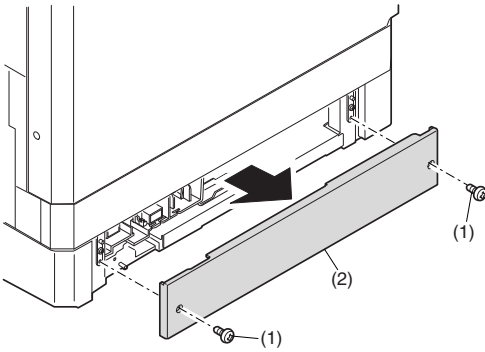

### D. 2nd tray transport clutch

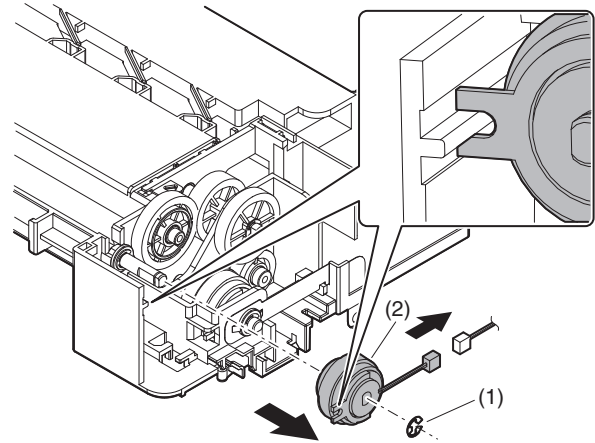
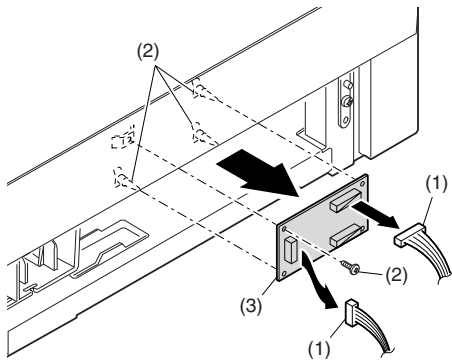

### E. 2nd tray transport roller

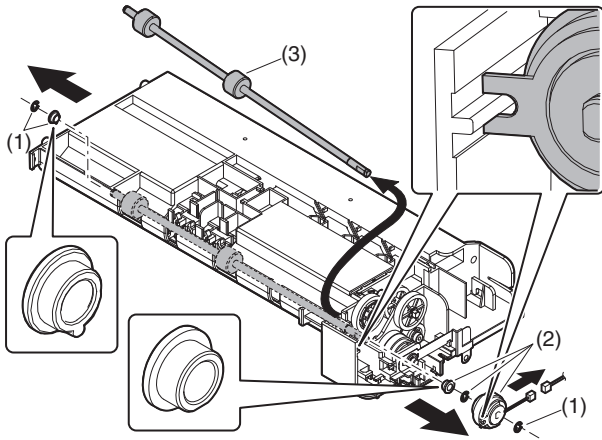

### H. Paper entry sensor

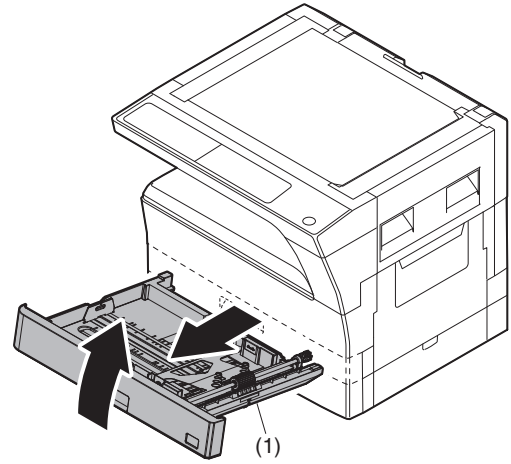

### F. 2nd tray paper feed clutch

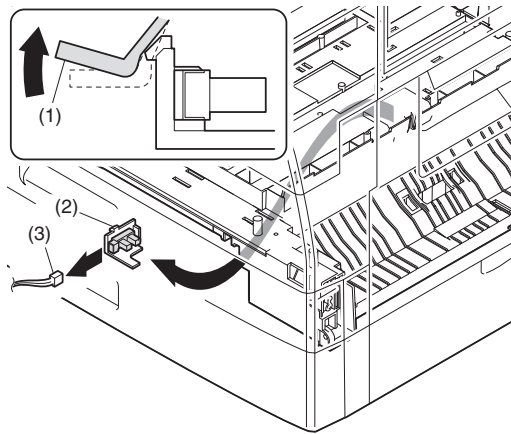
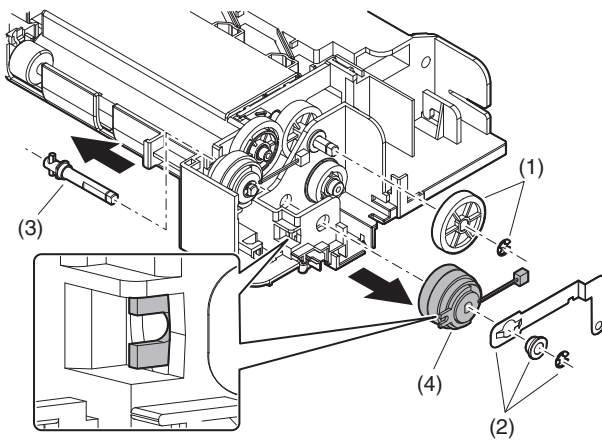

### G. Main motor

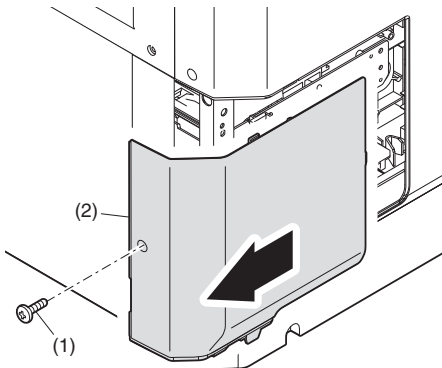

### I. Paper empty sensor

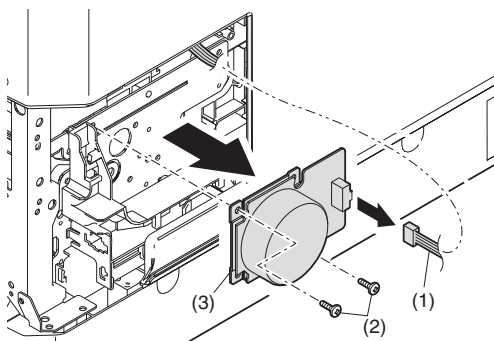
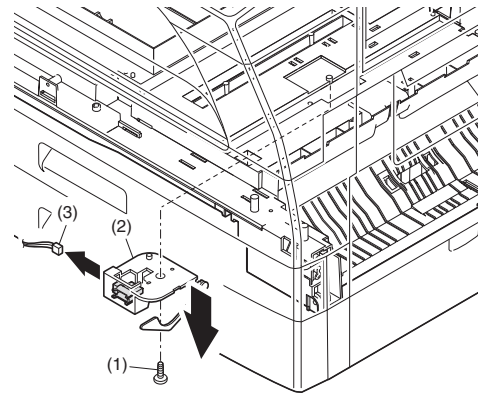

# [11] OPERATIONAL DESCRIPTIONS

## 1. Paper feed operation

- When copy/print movement is started, a main motor is a timing of the rotary (drive system) paper pickup, and a paper feed clutch does ON, and a paper feed roller turns.
- A transportation clutch does ON, and the paper is sent to the transportation department.
- \* By a separation plate to prevent against double feed of paper.

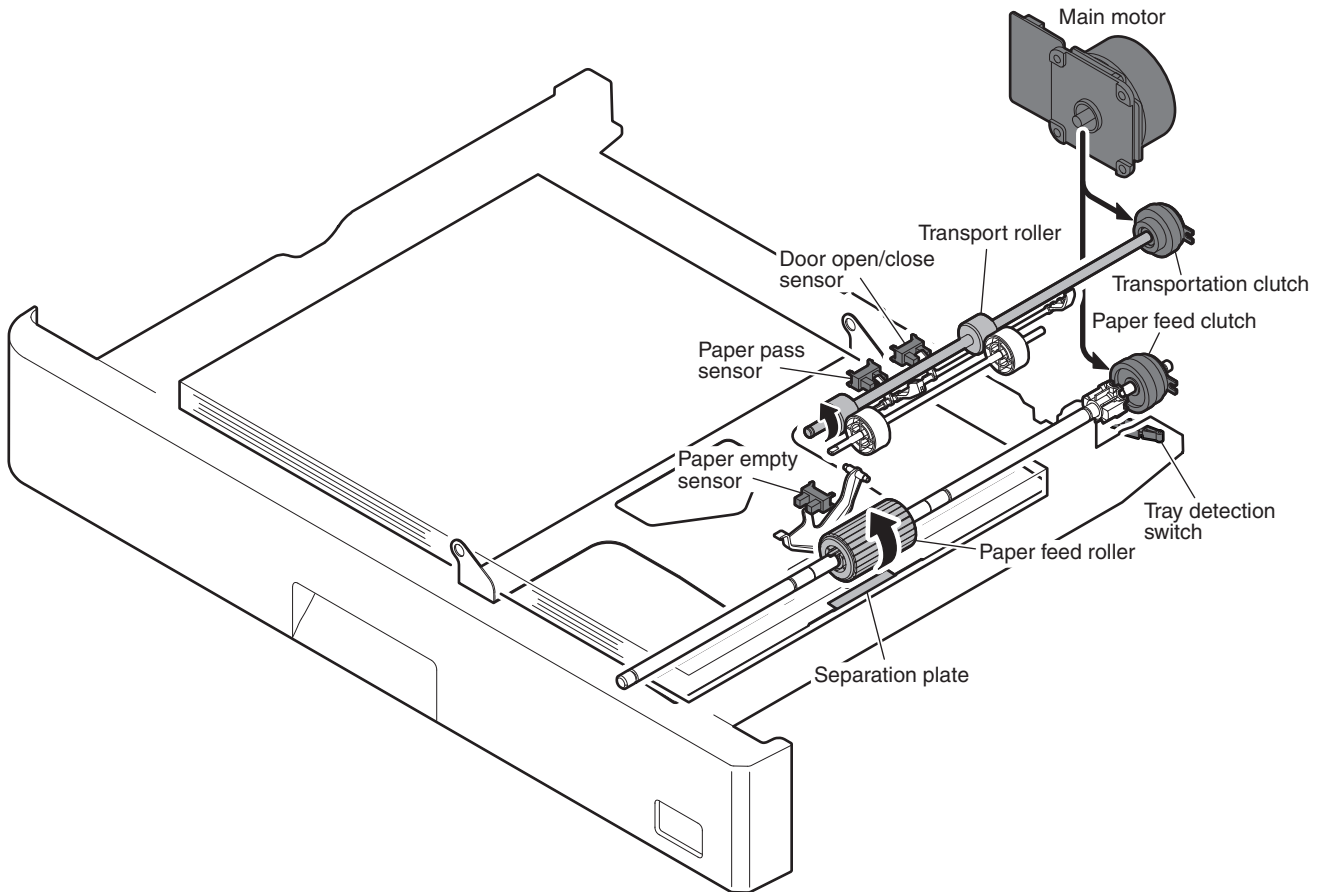

# [12] FLASH ROM VERSION UP PROCEDURE

\* AR-5618S/5620S only.

## 1.Preparation

Write the download data (the file with the extension dwl) to the main body.

### Necessary files for download

- Maintenance.exe (Maintenance software)
- ProcSirius.mdl
- ProcSirius.ini
- ProcSirius.fmt
- Mainte.inf
- Usbscan.sys
- Download file:\*\*\*.dwl

<Note>

- The Download file(\*\*\*.dwl ) and the like that are to be downloaded should be copied, in advance, into folders that have a maintenance program.
- When creating a folder for a maintenance tool in the PC, be sure that no lengthy folder name is included in the path.

(Example)

Incorrect c:\Maintenance Download Tool

Correct c:\Maintenance\Downtool

## 2.Download procedure

- 1) Main body side:  
Executable by performing the Service Simulation No. 49-01 (Flash Rom program-writing mode).  
(A word "d" appears on the operation panel to denote the download mode status. )
- 2) Connect the PC and the main body with the download cable (USB cable).

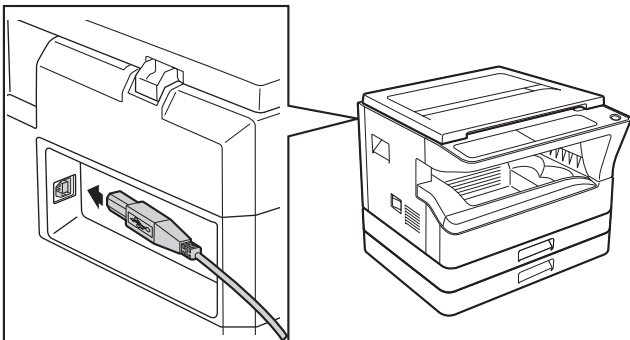

- 3) PC side:  
Boot the maintenance program. Select the model icon.

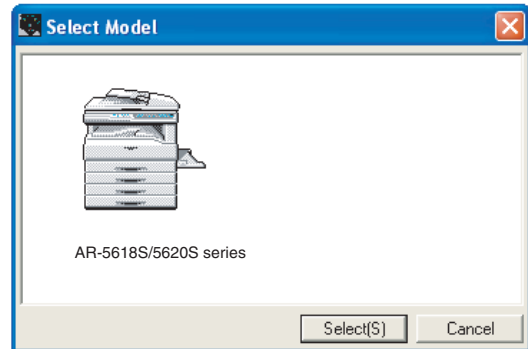

<Sample display>

- 4) PC side:  
Confirm that the "Simulation Command List" tree is displayed on the maintenance program.
- 5) PC side:  
When the message "the main body has not got started running" is displayed on the lowest area of the figure below after the "maintenance program" is started up, select the "File" and then "Reconnect" in the menu bar.

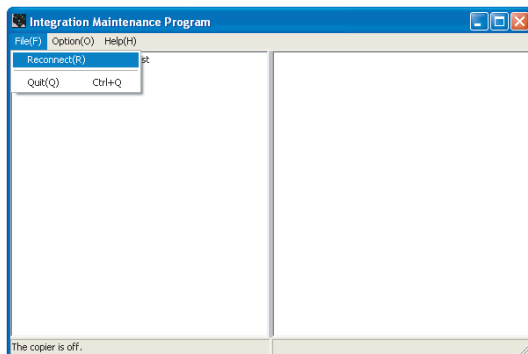

- 6) PC side:  
Confirm a tree is displayed under the "Special (MCU)" on the maintenance program". (If no tree is displayed, confirm that the USB is connected and select the "Reconnect" (the above 5) again.)

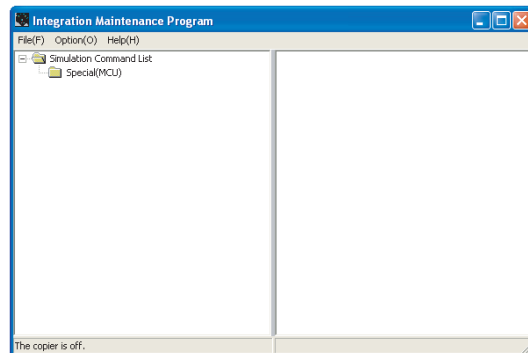

- 7) PC side:  
Double click "Special (MCU)" in the main tree item to develop the sub tree items, and double click "DWL Download" in the sub tree items.

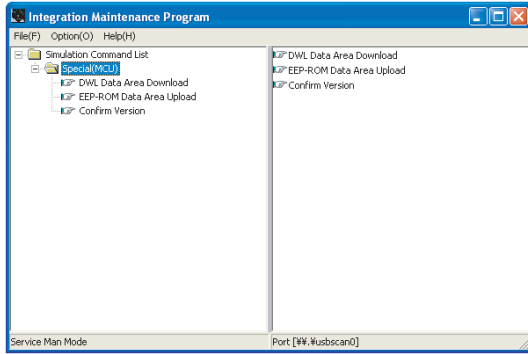

- 8) PC side:  
Specify the download file (\*.dwl).

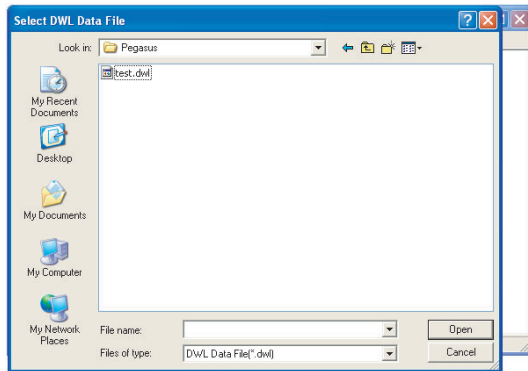

- 9) PC side:  
The download file is specified, download is automatically performed. The AUTO PAPER SELECT indicator and START indicator will blink approximately 15 seconds after the download file is specified.

- 10) PC side:  
When the message below is displayed, download is completed. Completion message: DOWNLOAD COMPLETED

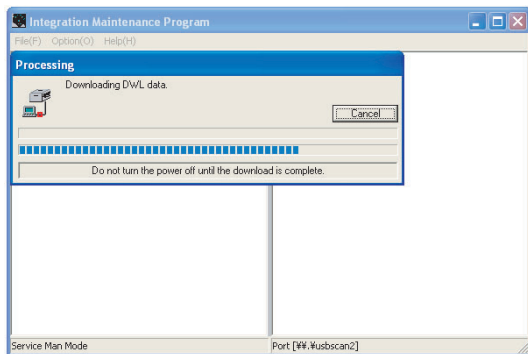

**NOTE (Important):**

- Be sure that the power is not turned off and the USB cable is not removed until the word "OFF" appears.

- 11) Main body side:  
Wait until the word "OFF" appears on the operation panel. The appearance of "OFF" indicates the completion of the download (writing into ROM). Turn the power off.

- 12) After-process: Terminate the maintenance program, and turn on the power of the main body.

After the download (data transmission) has been completed, exit the software program. The USB cable can be removed at this point.

**NOTE:**

- For making a second connection with another machine, select the "File" and "Reconnect" in the menu bar on the maintenance program at the time of the USB being re-connected. Repeat the previous procedures from the above 5).

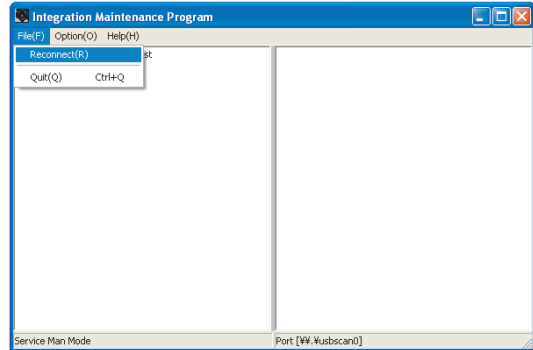

**\* Forbidden actions while downloading (Important)**

Failure in the download concerned may not allow you to conduct the subsequent download procedures. Added care should be taken to avoid having the situation below arise while downloading.

- Switching off the main body.
- Disconnecting the download cable (USB cable).

**\* If the above inhibit item occurs during downloading:**

Turn OFF and ON the power.

- 1) If "d" (which means downloading) is displayed on the operation panel LED of the machine, perform downloading again.
- 2) If "d" (which means downloading) is not displayed on the operation panel LED of the machine, turn OFF the power, and press and hold the [PAPER SELECT] key and the [AUTO/TEXT/PHOTO] key and turn ON the power. If, then, "d" (which means downloading) is displayed on the operation panel LED of the machine, perform downloading again.

If "d" is still not displayed, the MCU must be replaced.

### 3. Installation procedure

#### A. USB joint maintenance program installation

The driver is installed by plug and play.

#### B. Installation procedure on Windows XP

- 1) Machine side:  
Executable by performing the Service Simulation No. 49-01 (Flash Rom program-writing mode).  
(A word "d" appears on the operation panel to denote the download mode status. )
- 2) Connect the machine and the PC with a USB cable.

- 3) Check that the following display is shown. Select "Install from a list or the specific location" and press the NEXT button.



- 4) Select "Include this location in the search". If the retrieval area does not include the folder which includes the maintenance tool driver (Mainte.inf), select "Browse". If the folder path is properly shown, press the NEXT button to go to procedure 7).



- 5) Select the folder which includes the maintenance tool driver (Mainte.inf), and press the OK button. (When the driver is included in the "C:\Sirius" folder:)

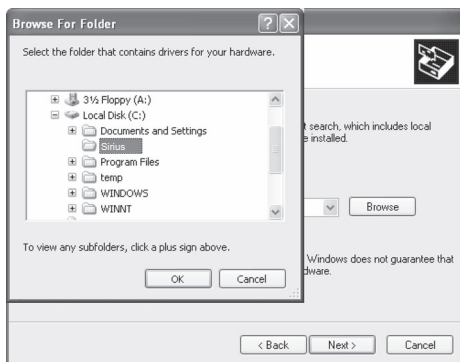

- 6) Check that the path to the folder which includes the maintenance tool driver (Mainte.inf) is shown, and press the NEXT button.

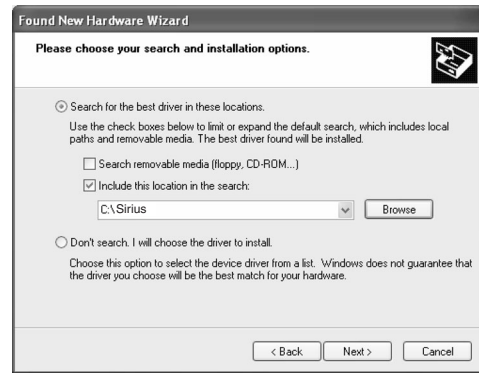

- 7) Check that the following display is shown. Press the Continue Anyway button.



- 8) When installation is completed, the following display is shown. Press the Finish button.



The installation procedure (on Windows XP) is completed with the above operation.

### C. Installation procedure on Windows 2000

- 1) Machine side:  
Executable by performing the Service Simulation No. 49-01 (Flash Rom program-writing mode).  
(A word "d" appears on the operation panel to denote the download mode status. )
- 2) Connect the machine and the PC with a USB cable.

- 3) Check that the new hardware search wizard is shown. Press the NEXT button.



- 4) Select "Search for a suitable driver for my device" and press the NEXT button.



- 5) Select "Specify a location" and press the NEXT button.



- 6) Press the "Browse" button. Specify the folder which includes the maintenance tool driver (Mainte.inf)



- 7) Specify the folder which includes the maintenance tool driver (Mainte.inf), and press the OPEN button. Check that the path to the folder which includes the maintenance tool driver (Mainte.inf) is properly displayed, and press the OK button. (When the maintenance tool driver is included in the folder of "D:\Sirius")

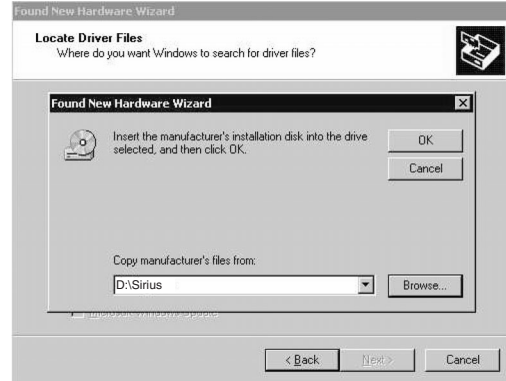

- 8) Press the NEXT button, and installation is started.



- 9) When installation is completed, the following display is shown. Press the Finish button.



The installation procedure of the joint maintenance program on Windows 2000 is completed with the above operation.

## 4. AR-5618N/5620N/5623N download procedures

- 1) Install the driver for the AR-5618N/5620N/5623N to a PC used for firmware update (hereinafter described as the download PC).
- 2) Prepare a cross cable and connect it to the download PC.
- 3) Disconnect the LAN cable (which is being used by the user) from the machine, and connect the cross cable to the machine.
- 4) Set the IP address of the machine.  
Execute "setup.exe" in the driver CD for the AR-5618N/5620N/5623N, and select [Set the OP Address].

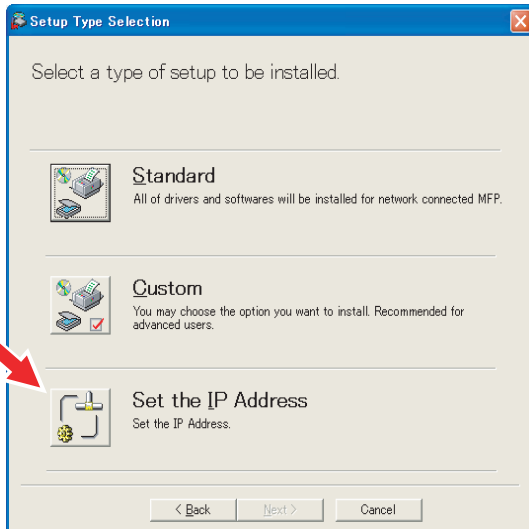

- 5) Press [Yes].

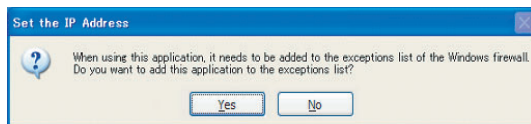

- 6) Check to confirm that [Ethernet Address] of the installed NIC PWB is displayed, and select [Ethernet Address] and press [Next >].

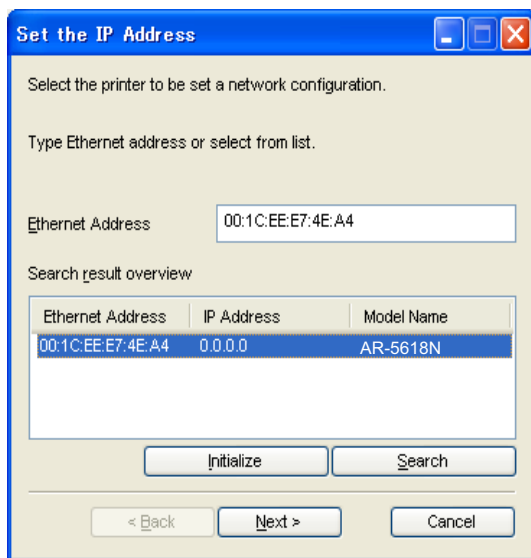

- 7) Enter the IP address, and press [Next >].  
If an error screen is not displayed, the IP address setting is completed.

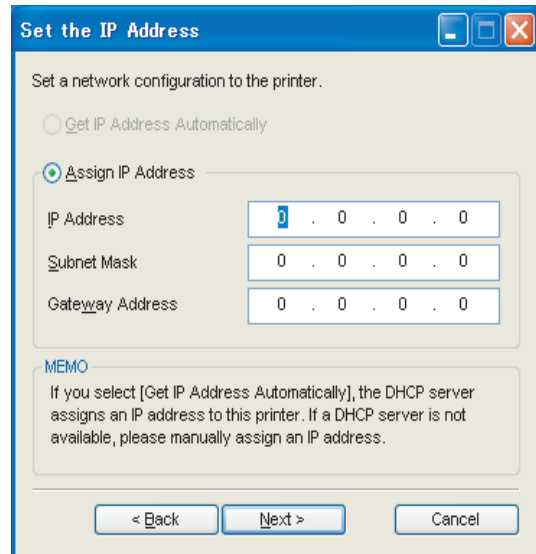

- 8) Set the IP address of the download PC to the fixed IP address (the same segment set to the machine in the procedure 4) ).
- 9) Boot the SC-SCAN.

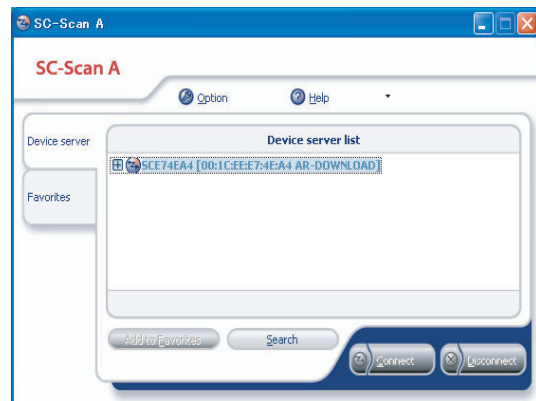

- 10) Execute SIM49-01 on the machine side.  
Select [SHARP AR-DOWNLOAD], and press [Connect].

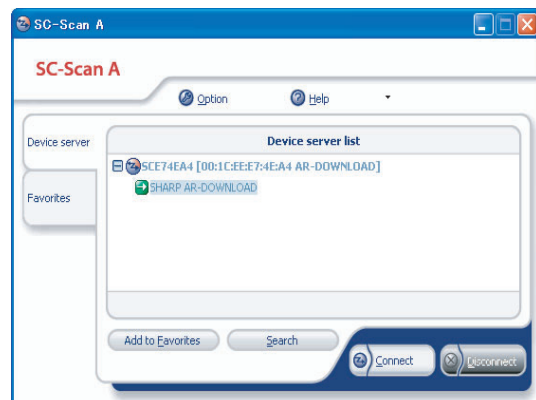

- 11) Boot the maintenance tool to execute downloading.  
(The same operations as the AR-5620N are executed.)
- 12) Reset the IP address of the machine and the download PC to the original states.





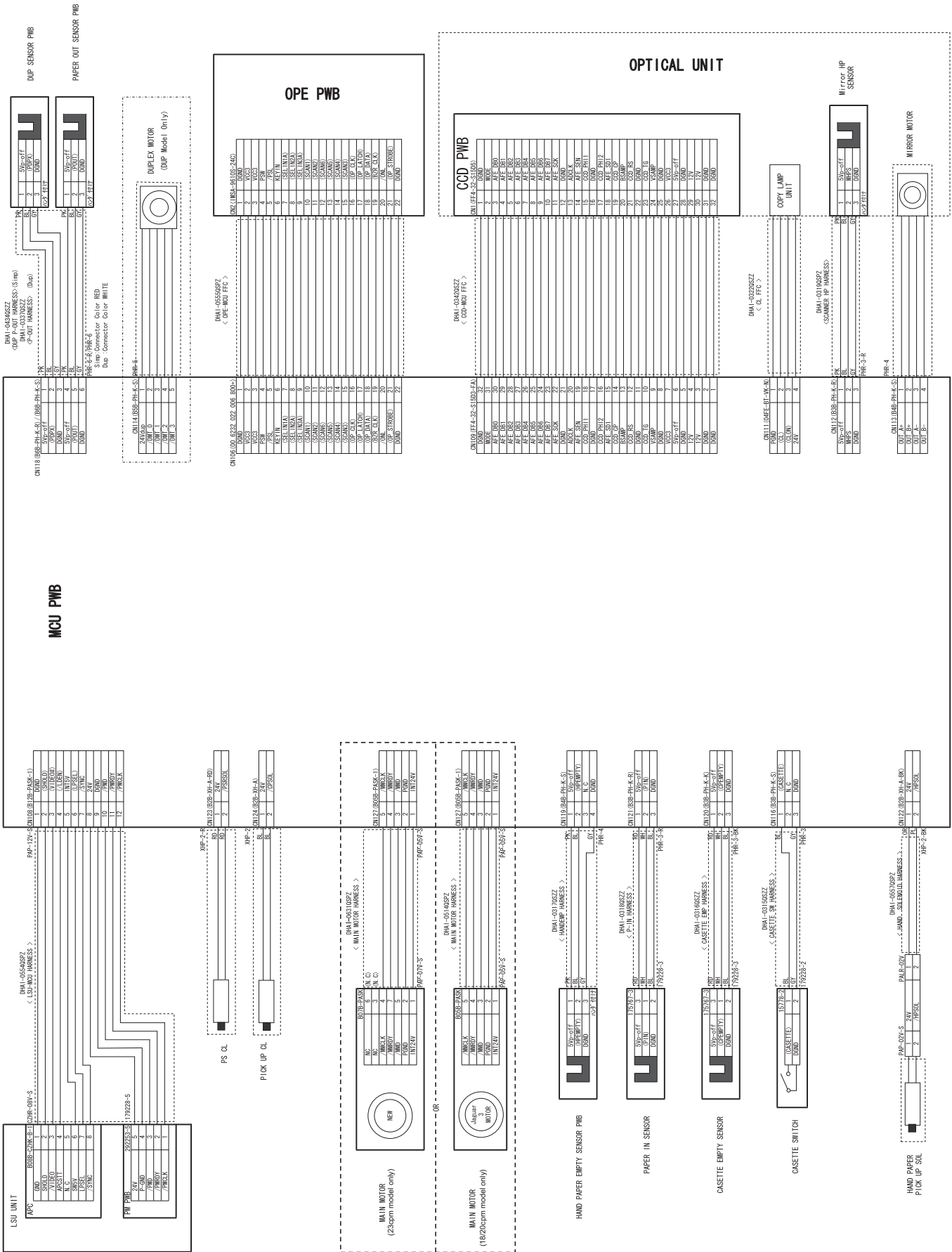

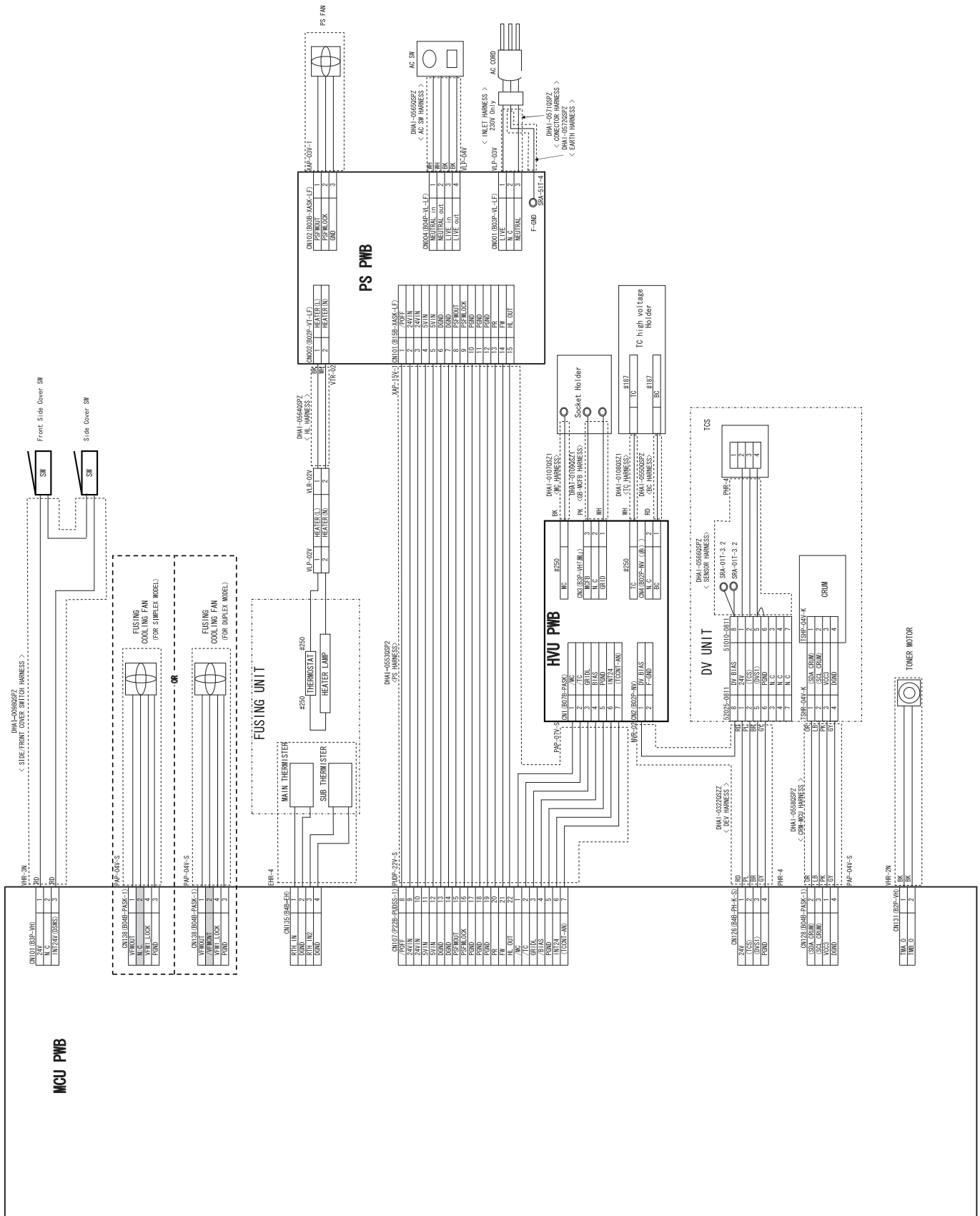





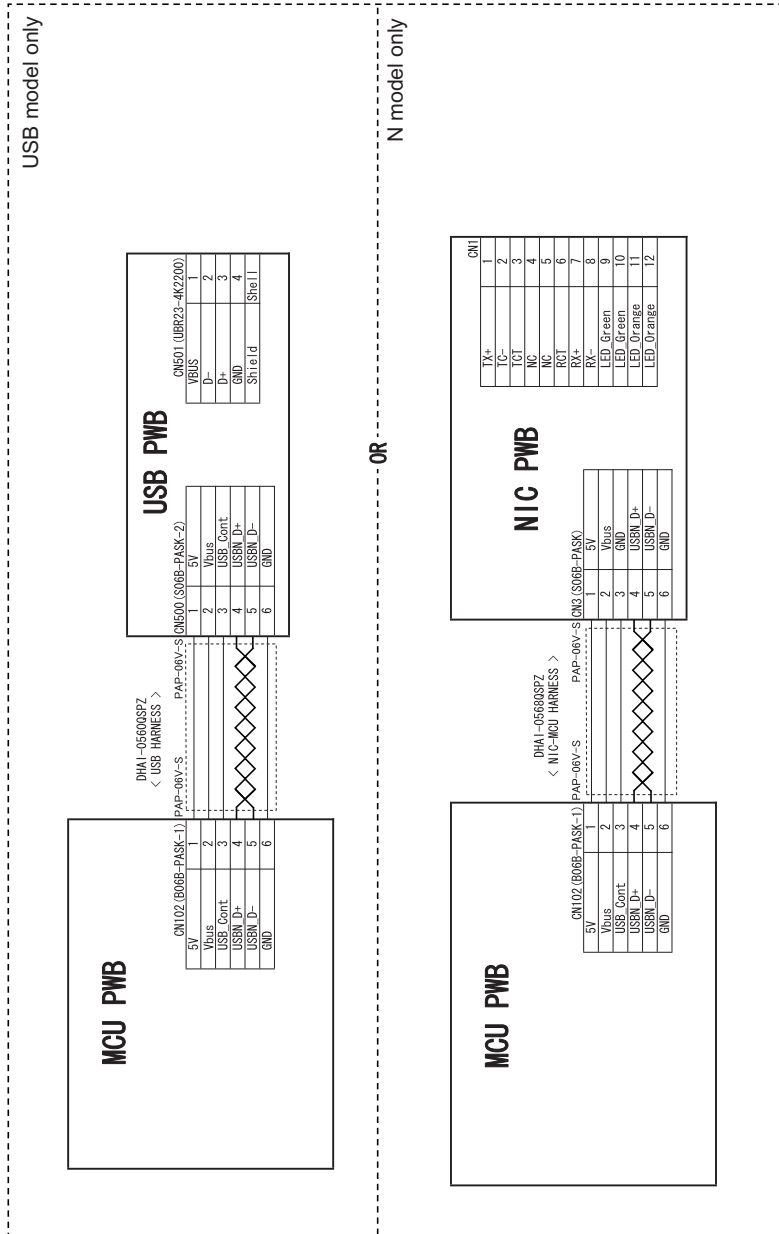

# LEAD-FREE SOLDER

The PWB's of this model employs lead-free solder. The "LF" marks indicated on the PWB's and the Service Manual mean "Lead-Free" solder. The alphabet following the LF mark shows the kind of lead-free solder.

**Example:**

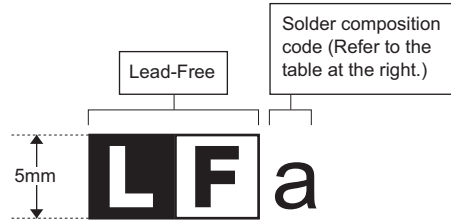

**<Solder composition code of lead-free solder>**

Solder composition	Solder composition code
Sn- <u>A</u> g-Cu	a
Sn-Ag-Bi Sn-Ag-Bi-Cu	b
Sn- <u>Z</u> n-Bi	z
Sn- <u>I</u> n-Ag-Bi	i
Sn-Cu- <u>N</u> i	n
Sn-Ag- <u>S</u> b	s
Bi-Sn-Ag- <u>P</u> Bi-Sn-Ag	p

**(1) NOTE FOR THE USE OF LEAD-FREE SOLDER THREAD**

When repairing a lead-free solder PWB, use lead-free solder thread.

Never use conventional lead solder thread, which may cause a breakdown or an accident.

Since the melting-point of lead-free solder thread is about 40°C higher than that of conventional lead solder thread, the use of the exclusive-use soldering iron is recommended.

**(2) NOTE FOR SOLDERING WORK**

Since the melting-point of lead-free solder is about 220°C, which is about 40°C higher than that of conventional lead solder, and its soldering capacity is inferior to conventional one, it is apt to keep the soldering iron in contact with the PWB for longer time. This may cause land separation or may exceed the heat-resistive temperature of components. Use enough care to separate the soldering iron from the PWB when completion of soldering is confirmed.

Since lead-free solder includes a greater quantity of tin, the iron tip may corrode easily. Turn ON/OFF the soldering iron power frequently.

If different-kind solder remains on the soldering iron tip, it is melted together with lead-free solder. To avoid this, clean the soldering iron tip after completion of soldering work.

If the soldering iron tip is discolored black during soldering work, clean and file the tip with steel wool or a fine filer.

# SHARP

**COPYRIGHT © 2011 BY SHARP CORPORATION**

All rights reserved.

Produced in Japan for electronic Distribution

No part of this publication may be reproduced,  
stored in a retrieval system, or transmitted,

in any form or by any means,

electronic; mechanical; photocopying; recording or otherwise  
without prior written permission of the publisher.

## **Trademark acknowledgements**

- Microsoft®, Windows®, Windows® 98, Windows® Me, Windows NT® 4.0, Windows® 2000, Windows® XP, Windows® Vista, Windows® 7, Windows® Server 2003, Windows® Server 2008 and Internet Explorer® are registered trademarks or trademarks of Microsoft Corporation in the U.S.A. and other countries.
- PostScript is a registered trademark of Adobe Systems Incorporated.
- Macintosh, Mac OS, AppleTalk, EtherTalk, Laser Writer, and Safari are registered trademarks or trademarks of Apple Inc.
- IBM, PC/AT, and Power PC are trademarks of International Business Machines Corporation.
- Acrobat® Reader Copyright® Adobe Systems Incorporated. All rights reserved. Adobe, the Adobe logo, Acrobat, and the Acrobat logo are trademarks of Adobe Systems Incorporated.
- PCL is a registered trademark of the Hewlett-Packard Company.
- Sharpdesk is a trademark of Sharp Corporation.
- All other trademarks and copyrights are the property of their respective owners.

**SHARP CORPORATION**

**Document Solutions Group**

**CS Promotion Center**

**Yamatokoriyama, Nara 639-1186, Japan**

2011 February Produced in Japan for electronic Distribution