

SHARP PARTS GUIDE

CODE:00ZAR5623P002

デジタル複合機 DIGITAL MULTIFUNCTIONAL SYSTEM

改訂版
Revised Edition

AR-5623N/5623
AR-5623D/5623DA
AR-5620N/5620
AR-5620D/5620S
AR-5618N/5618
AR-5618D/5618S
AR-5620SL

MODEL AR-VR7

このパーツガイドに掲載されている表示価格ランクは消費税抜きです。

CONTENTS

- | | |
|---------------------------------------|---|
| 1 外装 (Exteriors) | 16 手差しマルチユニット
(Manual paper feed multi unit) |
| 2 操作部 (Operation panel section) | 17 排紙フレームユニット (Delivery frame unit)
[AR-5620S/5618S/5623/5620/5618/
5620SL] |
| 3 サイドドアユニット (Side door unit) | 18 排紙フレームユニット (Delivery frame unit)
[AR-5623N/5620N/5618N/5623D/
5623DA/5620D/5618D] |
| 4 光学ユニット 1(Optical unit 1) | 19 TC ケースユニット (TC case unit) |
| 5 光学ユニット 2(Optical unit 2) | 20 250 枚トレイユニット (250 sheets tray unit) |
| 6 ランプ ユニット (Lamp unit) | 21 2nd トレイ外装 (2nd tray exteriors)
[AR-5623N/5620N/5623/5620/5623D/
5623DA/5620D] |
| 7 第 2,3 ミラーユニット (2nd,3rd mirror unit) | 22 2nd トレイ給紙ユニット
(2ndtraypaperfeedunit)
[AR-5623N/5620N/5623/5620/5623D/
5623DA/5620D] |
| 8 中間フレームユニット (Middle frame unit) | 23 梱包材 & 付属品
(Packing material & Accessories) |
| 9 フォトユニット (Process unit) | |
| 10 現像ユニット (DV unit) | |
| 11 定着ユニット (Fusing unit) | |
| 12 メイン駆動ユニット (Main driving unit) | |
| 13 台板ユニット 1(Base plate unit 1) | |
| 14 台板ユニット 2(Base plate unit 2) | |
| 15 台板ユニット 3(Base plate unit 3) | |

<修正パーツガイド活用時の注意>







・ 部品の互換性は下表の通り、No1～6で表現しております。

<互換性>

1	新・旧の互換性有り。
2	新の代わりに旧は使用可。 旧の代わりに新は使用不可。
3	新の代わりに旧は使用不可。 旧の代わりに新は使用可。
4	新・旧の互換性無。
5	旧 (a, b, c...) どうし一対、又は 新 (a, b, c...) どうし一対で、 互換性有。
6	その他

・ 部品の追加・変更・廃止・員数の増減等の変更は下表のマークで表現しております。

<変更区分>

新規追加	
変 更	
廃 止	
員数増・その他	
員数減	
パーツ修正	

・ 変更時期のランニングチェンジは、R/Cとして記載しています。

<変更時期>

R / C	ランニングチェンジ
-------	-----------

<Note for use of the revised Parts Guide>







・ Interchangeability of parts is expressed by No1~6 as shown in the table below.

<Interchangeability>

1	Interchangeable.
2	Current type can be used in place of new type. New type cannot be used in place of current type.
3	Current type cannot be used in place of new type. New type can be used in place of current type.
4	Not interchangeable.
5	Interchangeable if replaced with same types of related parts in use.
6	Others.

・ New & Addition, Change, Abolition, and Quantity change are expressed with the marks shown in the table below.

<Change of Division>

New & Addition	
Change	
Abolition	
Quantity (increase) /Others	
Quantity (decrease)	
Correction	

・ Running Change of Effective Time is expressed as R/C.

<Effective Time>

R / C	Running Change
-------	----------------

補修部品のランク付

市場における補修部品の在庫管理が、適正に運営出来る手助けとなることを、目的とします。

- Aランク : メンテナンスパーツ、メンテナンスパーツには入っていないがメンテナンスパーツに近い消耗パーツ。
 Bランク : 性能・機能パーツ (センサー、クラッチ等の電気パーツ)、消耗パーツ。
 Eランク : 基板含むユニットパーツ。
 Dランク : 整備パーツ (外装、パッキング、同梱パーツ)。
 Cランク : 上記ランク以外のパーツ (基板の子部品を除いたもの)。

DEFINITION

- Rank A : Maintenance parts, and consumable parts which are not included in but closely related to maintenance parts
 Rank B : Performance/function parts (sensors, clutches, and other electrical parts), consumable parts
 Rank E : Unit parts including PWB
 Rank D : Preparation parts (External fitting, packing, parts packed together)
 Rank C : Parts other than the above (excluding sub components of PWB)

安全性・信頼性確保のため部品は、必ず正規のものをご使用下さい。

△印の商品は、安全上重要な部品です。交換をする時は、安全及び性能維持のため必ず指定の部品をご使用下さい。

Because parts marked with "△" is indispensable for the machine safety maintenance and operation, it must be replaced with the parts specific to the product specification.

- 当モデルのサービス資料には、この資料以外にサービスマニュアル (回路図含む) があります。合わせてご利用下さい。
- Other than this Parts Guide, please refer to documents Service Manual (including Circuit Diagram) of this model.
- Please use the 13 digit code described in the right hand corner of front cover of the document, when you place an order.
- For U.S. only-Use order codes provided in advertising literature. Do not order from parts department.

1 外装 (Exteriors)

NO.	PARTS CODE	Inter-change	PRICE RANK		NEW MARK	PART RANK	DESCRIPTION	TR No.	Effective time
			Ex.	Ja.					
1	GC0V-0075QSZ2		BC	GD		D	OC cover [AR-5623/5620/5618/5620S/5618S/5620SL,AR-VR7] OCカバー		
2	PCUSS0032QSZ2		AR	EQ		C	OC mat(Refer to Matrix) OCマット		
	PCUSS0032QSZZ		AW	FG		C	OC mat(Refer to Matrix) OCマット		
3	MHNG-0030QSZZ		BD	GN		C	OC hinge [AR-5623/5620/5618/5620S/5618S/5620SL,AR-VR7] OCヒンジ		
4	XEBS740P12000		AA	DD		C	Screw(4×12) [AR-5623/5620/5618/5620S/5618S/5620SL,AR-VR7] ビス		
5	XEBS730P08000		AC	DD		C	Screw(3×8) ビス		
6	LBNDZ0006QSZZ		AC	DJ		C	Front cabinet band 前キャビネット		
7	CFIX-0024QS24		AQ	EQ		D	Glass fixing plate(Refer to Matrix) ガラス押え板		
8	PGLSP0003QSZZ		BA	FX		C	Table glass テーブルガラス		
9	PSHEZ0220QSZ1		AK	DX		C	Shading sheet シェーディングシート		
10	GCAB-0124QSZ1		AU	EZ		D	Front cabinet inner 前キャビネットインナー		
11	GC0V-0077QSZ1		AU	EZ		D	Front cover main 前カバーメイン		
12	GC0V-0076QSZ1		AH	DX		D	Front cover sub 前カバーサブ		
13	GC0V-0048QST2		AP	EQ		D	Rear cabinet maintenance cover 後キャビネットメンテナンスカバー		
14	LX-BZ0088QSPZ		AA	DD		C	Screw(3×6) ビス		
16	GC0V-0047QST5		AM	EG		D	Rear cabinet cover(Refer to Matrix) 後キャビネットカバー		
	GC0V-0093QSZZ		AR	EQ		D	Rear cabinet cover(Refer to Matrix) 後キャビネットカバー		
17	XHBS730P08000		AB	DD		C	Screw(3×8) ビス		
18	GCAB-0070QST8		AZ	EQ		D	Rear cabinet(Refer to Matrix) 後キャビネット		
19	PGIDM0110QST2		AH	DX		C	Hinge guide L ヒンジガイドL		
20	XHBS730P06000		AC	DD		C	Screw(3×6) ビス		
21	PGIDM0111QST2		AH	DX		C	Hinge guide R ヒンジガイドR		
22	LFIX-0026QSA2		AN	EG		C	OC glass fixture OCガラス押え		
23	GCAB-0015QSTD		AV	FG		D	Right cabinet 右キャビネット		
24	XEBS740P10000		AA	DD		C	Screw(4×10) ビス		
25	LX-BZ0759FCPZ		AC	DD		C	Screw(3×6) ビス		
26	XBBS730P06000		AC	DD		C	Screw(3×6) ビス		
28	GC0V-0247FCZ1		AR	EQ		D	OC stocker [AR-5623/5620/5618/5620S/5618S/5620SL,AR-VR7] OCストックャー		
29	TCAUA1069FCZZ		AC	DJ		D	Service caution label サービス注意ラベル		
30	CBDGD0002QS21		AK	DX		D	Model name plate(Refer to Matrix) 機種名プレート		
	CBDGD0002QS22		AK	DX		D	Model name plate(Refer to Matrix) 機種名プレート		
	CBDGD0002QS28		AK	DX		D	Model name plate(Refer to Matrix) 機種名プレート		
	CBDGD0002QS30		AK	DX		D	Model name plate(Refer to Matrix) 機種名プレート		
	CBDGD0002QS32		AK	DX		D	Model name plate(Refer to Matrix) 機種名プレート		
	CBDGD0002QS26		AG	DX		D	Model name plate(Refer to Matrix) 機種名プレート		
	CBDGD0002QS27		AG	DX		D	Model name plate(Refer to Matrix) 機種名プレート		
	CBDGD0002QS29		AG	DX		D	Model name plate(Refer to Matrix) 機種名プレート		
	CBDGD0002QS31		AG	DX		D	Model name plate(Refer to Matrix) 機種名プレート		
	CBDGD0002QS33		AG	DX		D	Model name plate(Refer to Matrix) 機種名プレート		
CBDGD0002QS34		AG	DX		D	Model name plate(Refer to Matrix) 機種名プレート			
31	XWVS740-05000		AA	DD		C	Washer [AR-5623/5620/5618/5620S/5618S/5620SL,AR-VR7] ワッシャー		
32	TCAUH1071FCZZ		BC	GD		D	Service caution label PO [Greece,Cyprus,Turkey, Poland,Hungary,Czech,Slovakia] サービス注意ラベル PO		

1 外装 (Exteriors)

Matrix

No.2	OC マット (OC mat)											
PARTS CODE	Germany, Switzerland, France			India			Lebanon, Nigeria, Algeria, Egypt, Jordan, Tunisia, Morocco			Other		
	AR-5620S AR-5618S									AR-VR7		
PCUSS0032QSZ2	1st lot	1st lot	1st lot									
PCUSS0032QSZZ				1st lot	1st lot	1st lot	1st lot					

No.7-1/2	ガラス押え板 (Glass fixing plate)									
PARTS CODE	India, Singapore, Malaysia, Vietnam		Other		India Malaysia, Vietnam		Philippines		Other	
	AR-5623N AR-5618N				AR-5620N				AR-5620S	
CFIX-0024QS24	1st lot				1st lot			1st lot	1st lot	

No.7-2/2	ガラス押え板 (Glass fixing plate)									
PARTS CODE	Mexico, LAG2, Philippines		India, Singapore, Vietnam		Other		Argentina		India, Singapore, Vietnam	
	AR-5623D				AR-5623DA		AR-5620D AR-5618D		AR-5620SL	
CFIX-0024QS24			1st lot				1st lot		1st lot	

No.16	後キャビネットカバー (Rear cabinet cover)									
PARTS CODE	AR-5623N AR-5620N		AR-5618N		AR-5620S AR-5618S		AR-5623		AR-5620D AR-5618D	
	AR-5623DA		AR-5620SL							
GCOV-0047QST5	1st lot									
GCOV-0093QSZZ				1st lot	1st lot	1st lot				

1 外装 (Exteriors)

Matrix

No.18	後キャビネット (Rear cabinet)												
PARTS CODE	AR-5623N	AR-5620N	AR-5618N	AR-5620S	AR-5618S	AR-5623	AR-5620	AR-5618	AR-5623D	AR-5620D	AR-5618D	AR-5623DA	AR-5620SL
	ALL	ALL	ALL	Mexico, LAG2	Other	ALL	Argentina	ALL					
GCAB-0070QST8	1st lot	1st lot											1st lot

No.30	機種名プレート (Model name plate)												
PARTS CODE	AR-5618S	AR-5620S	AR-5623N	AR-5620N	AR-5618N	AR-5618	AR-5620	AR-5623	AR-5618D	AR-5620D	AR-5623D	AR-5623DA	AR-5620SL
	CBDGD0002QS21	CBDGD0002QS22	CBDGD0002QS28	CBDGD0002QS30	CBDGD0002QS32	CBDGD0002QS26	CBDGD0002QS27	CBDGD0002QS29	CBDGD0002QS31	CBDGD0002QS33	CBDGD0002QS34		
	1st lot			1st lot		1st lot							
					1st lot								
		1st lot											
			1st lot										
						1st lot			1st lot				
							1st lot			1st lot			
								1st lot				1st lot	
											1st lot		

No.501-1/2	右キャビネット AS (Right cabinet AS)													
PARTS CODE	AR-5623N			AR-5620N			AR-5618N			AR-5620S			AR-5618S	
	Germany, Switzerland, France, Spain, Italy	Australia, New Zealand	India, Singapore, Malaysia	Other	Germany, Switzerland, France, Spain, Italy	Australia, New Zealand	India, Malaysia, Vietnam	Other	Germany, Switzerland, France, Spain, Italy	India, Singapore, Malaysia, Vietnam	Other	Germany, Switzerland, France	India	Lebanon, Nigeria, Algeria, Egypt, Jordan, Tunisia, Morocco
CCAB-0015RS51	1st lot	1st lot	1st lot		1st lot	1st lot	1st lot		1st lot	1st lot		1st lot	1st lot	1st lot

No.501-2/2	右キャビネット AS (Right cabinet AS)												
PARTS CODE	AR-5623	AR-5620	AR-5618	AR-5623D	AR-5620D	AR-5618D	AR-5623DA	AR-5620SL					
	ALL	ALL	Argentina	ALL									

1 外装 (Exteriors)

Matrix

No.502-1/3		テーブルユニット (Table unit)										
PARTS CODE	AR-5623N			AR-5620N				AR-5618N				
	Germany, Switzerland, France, Spain, Italy	Australia, New Zealand	India, Singapore, Malaysia, Vietnam	Other	Germany, Switzerland, France, Spain, Italy	Australia, New Zealand	India, Malaysia, Vietnam	Philippines	Other	Germany, Switzerland, France, Spain, Italy	India, Singapore, Malaysia, Vietnam	Other
CF i X-0024RS70	1st lot	1st lot			1st lot	1st lot				1st lot	1st lot	
CF i X-0024US70	Apr/11	Apr/11		1st lot	Apr/11	Apr/11			1st lot	Apr/11		1st lot
CF i X-0024RS72			1st lot				1st lot				1st lot	
CF i X-0024US72			Apr/11				Apr/11	1st lot			Apr/11	

No.502-2/3		テーブルユニット (Table unit)												
PARTS CODE	AR-5620S AR-5618S				AR-5623 AR-5620		AR-5618			AR-5623D			AR-5620D	
	India	Germany, Switzerland, France	Lebanon, Nigeria, Algeria, Egypt, Jordan, Tunisia, Morocco	Other	India, Singapore, Malaysia, Vietnam	Other	India, Singapore, Malaysia, Vietnam	Philippines	Other	Mexico, LAG2, Philippines	India, Singapore, Vietnam	Other	India, Singapore, Vietnam	Other
CF i X-0024RS70	1st lot	1st lot	1st lot											
CF i X-0024US70				1st lot		1st lot			1st lot	1st lot	1st lot	1st lot	1st lot	1st lot
CF i X-0024US72					1st lot		1st lot	1st lot						

No.502-3/3		テーブルユニット (Table unit)												
PARTS CODE	AR-5623DA		AR-5618D		AR-5620SL									
	Argentina	India, Singapore, Vietnam	Other	India, Singapore, Vietnam	Other									
CF i X-0024US70			1st lot		1st lot									
CF i X-0024US72	1st lot	1st lot		1st lot										

1 外装 (Exteriors)

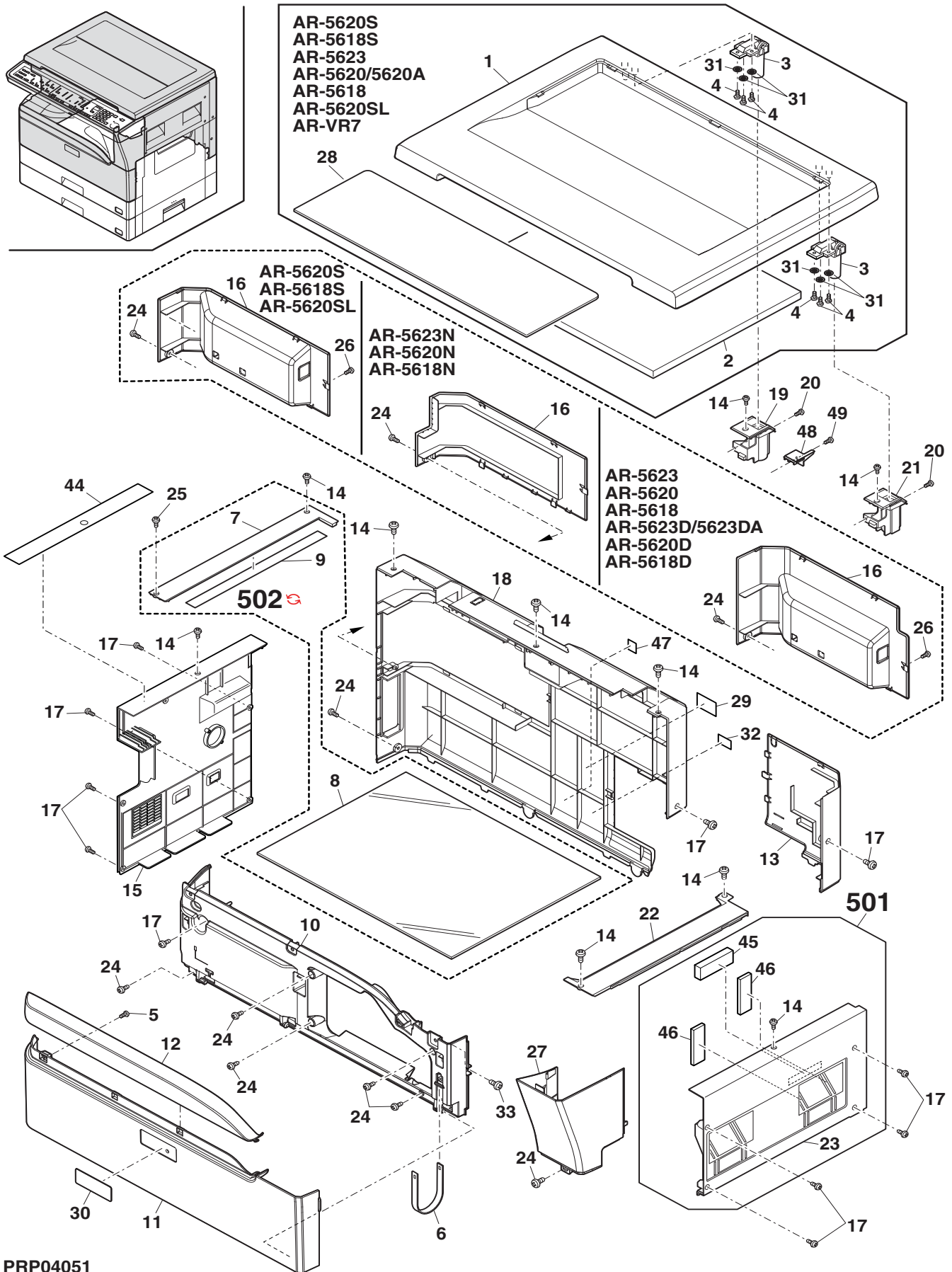

2 操作部 (Operation panel section)

NO.	PARTS CODE	Inter-change	PRICE RANK		NEW MARK	PART RANK	DESCRIPTION	TR No.	Effective time
			Ex.	Ja.					
1	GCAB-0125QSZ1		AV	FG		D	Operation panel cabinet		
4	LX-BZ0088QSPZ		AA	DD		C	Screw(3×6)		
5	XHBS730P08000		AB	DD		C	Screw(3×8)		
6	PSPA Z0056QSZZ		AC	DJ		C	Spacer		
7	XEBS730P08000		AC	DD		C	Screw(3×8)		
8	GCAB-0126QSZ1		AL	EB		D	Operation lower cabinet		
9	CPNLH0064QS06		AK	EB		D	Key sheet main(Refer to Matrix)		
	CPNLH0064QS07		AK	DX		D	Key sheet main(Refer to Matrix)		
	CPNLH0064QS08		AS	EZ		D	Key sheet main(Refer to Matrix)		
10	CPNLH0065QS11		AK	DX		D	Key sheet sub(Refer to Matrix)		
	CPNLH0065QS12		AK	DX		D	Key sheet sub(Refer to Matrix)		
	CPNLH0065QS13		BH	GX	N	D	Key sheet sub(Refer to Matrix)		
11	CCOV-0079QS05		BG	GT		D	Operation panel cover(Refer to Matrix)		
	CCOV-0079QS06		AT	EZ		D	Operation panel cover(Refer to Matrix)		
12	PF i L W 0 0 1 9 Q S B Z		AE	DS		C	Copy key ring		
13	CBTN-0122QS01		AF	DS		C	Start key AS		
14	CBTN-0109QS02		AE	DS		C	Interrupt key		
15	CBTN-0102QS01		AE	DS		C	CA key		
16	PLNS-0013QSZZ		AC	DJ		B	LED lens PEG3		
17	CBTN-0103QS01		AK	DX		C	Ten key		
18	JBTN-0105QSAZ		AE	DJ		C	Magnification key		
19	CBTN-0104QS01		AE	DS		C	Zoom key		
20	JBTN-0106QSAZ		AD	DJ		C	Mode select key		
21	JBTN-0108QSZZ		AC	DJ		C	Automatic key		
22	JBTN-0110QSZZ		AD	DJ		C	Special function key(Refer to Matrix)		
	JBTN-0110QSZ2		AD	DJ		C	Special function key(Refer to Matrix)		
	JBTN-0110QSZ1		AD	DJ		C	Special function key(Refer to Matrix)		
23	CBTN-0107QS01		AG	DX		C	Contracted key [AR-5623/5623N/5623D/5623DA/5620/5620N/5620D/5618/5618N/5618D/5620SL]		
24	DUNTK0717QS12		BT	NE		E	Operation PWB(Refer to Matrix)		
	DUNTK0717QSZZ		BP	LP		E	Operation PWB(Refer to Matrix)		
	DUNTK0717USZZ		BG	GT	N	E	Operation PWB(Refer to Matrix)		
	DUNTK0717US11		BG	GT	N	E	Operation PWB(Refer to Matrix)		
25	DHA i - 0 5 5 5 Q S P Z		AZ	FQ		C	OP MCU FFC harness		
	(Unit)								
901	CCAB-0125RS64		BM	HR		E	Operation panel unit(Refer to Matrix)		
	CCAB-0125US64	1	BM	HV	N	E	Operation panel unit(Refer to Matrix)		
	CCAB-0125RS65		BM	HV		E	Operation panel unit(Refer to Matrix)		
	CCAB-0125US65	1	BN	HZ	N	E	Operation panel unit(Refer to Matrix)		
	CCAB-0125US69		BP	LP	N	E	Operation panel unit(Refer to Matrix)		
	CCAB-0125US70		BN	LE	N	E	Operation panel unit(Refer to Matrix)		
	CCAB-0125US71		BN	HZ	N	E	Operation panel unit(Refer to Matrix)		

Matrix

No.9	キートメイン (Key sheet main)																	
PARTS CODE	AR-5623N AR-5618N		AR-5620N		AR-5620S AR-5618S		AR-5623 AR-5620		AR-5618		AR-5623D		AR-5620D AR-5618D		AR-5623DA		AR-5620SL	
	ALL	Philippines	Other	ALL	ALL	Philippines	Other	Mexico, LAG2	Philippines	Other	ALL	Argentina	ALL					
CPNLH0064QS06				1st lot														1st lot
CPNLH0064QS07	1st lot		1st lot		1st lot		1st lot				1st lot	1st lot	1st lot	1st lot				
CPNLH0064QS08		1st lot				1st lot		1st lot	1st lot									

② 操作部 (Operation panel section)

Matrix

No.10	キーシート [*] (Key sheet sub)																			
PARTS CODE	AR-5623N	AR-5620N	AR-5618N	AR-5620S	AR-5618S	AR-5623	AR-5620	AR-5618	AR-5623D	AR-5620D	AR-5618D	AR-5623DA	AR-5620SL							
CPNLH0065QS11			1st lot																	
CPNLH0065QS12	1st lot								1st lot	1st lot										
CPNLH0065QS13				1st lot								1st lot								

No.11	操作パネル [*] - (Operation panel cover)																			
PARTS CODE	AR-5623N	AR-5620N	AR-5618N	AR-5620S	AR-5618S	AR-5623	AR-5620	AR-5618	AR-5623D	AR-5620D	AR-5618D	AR-5623DA	AR-5620SL							
CCOV-0079QS05	1st lot					1st lot			1st lot	1st lot		1st lot	1st lot							
CCOV-0079QS06				1st lot																

No.22	特殊キー (Special function key)																			
PARTS CODE	AR-5623N	AR-5620N	AR-5618N	AR-5620S	AR-5618S	AR-5623	AR-5620	AR-5618	AR-5623D	AR-5620D	AR-5618D	AR-5623DA	AR-5620SL							
JBTN-0110QSZZ	1st lot								1st lot	1st lot										
JBTN-0110QSZ2				1st lot																
JBTN-0110QSZ1						1st lot							1st lot							

No.24-1/2	操作基板 (Operation PWB)																																						
PARTS CODE	Germany, Switzerland, France, Spain, Italy			India, Singapore, Malaysia, Vietnam, Australia, New Zealand			Other			Germany, Switzerland, France, Spain, Italy			India, Malaysia, Vietnam, Australia, New Zealand			Other			Germany, Switzerland, France, Spain, Italy			India, Singapore, Malaysia, Vietnam			Other			Germany, Switzerland, France			India			Lebanon, Nigeria, Algeria, Egypt, Jordan, Tunisia, Morocco			Other		
DUNTK0717QS12																																							
DUNTK0717QSZZ	1st lot	1st lot	1st lot				1st lot	1st lot	1st lot				1st lot	1st lot						1st lot	1st lot				1st lot	1st lot	1st lot												
DUNTK0717USZZ						1st lot						1st lot								1st lot				1st lot															

No.24-1/2	操作基板 (Operation PWB)																				
PARTS CODE	AR-5623D	AR-5620D	AR-5618D	AR-5623DA	AR-5623	AR-5620	AR-5618	AR-5620SL													
DUNTK0717USZZ	1st lot	1st lot																			
DUNTK0717US11				Argentina	ALL			SLL													
					1st lot			1st lot													

② 操作部 (Operation panel section)

Matrix

No.901-1/2		操作パネルユニット (Operation panel unit)											
PARTS CODE	AR-5623N			AR-5620N				AR-5618N			AR-5620S AR-5618S		
	Germany, Switzerland, France, Spain, Italy, Australia, New Zealand	India, Singapore, Malaysia, Vietnam	Other	Germany, Switzerland, France, Spain, Italy, Australia, New Zealand	India, Malaysia, Vietnam	Philippines	Other	Germany, Switzerland, France, Spain, Italy	India, Singapore, Malaysia, Vietnam	Other	India, Germany, Switzerland, France	Lebanon, Nigeria, Algeria, Egypt, Jordan, Tunisia, Morocco	Other
CCAB-0125RS64											1st lot	1st lot	
CCAB-0125US64											Apr/11	Apr/11	1st lot
CCAB-0125RS65	1st lot	1st lot		1st lot	1st lot			1st lot	1st lot				
CCAB-0125US65	Apr/11	Apr/11	1st lot	Apr/11	Apr/11		1st lot	Apr/11	Apr/11	1st lot			
CCAB-0125US69						1st lot							

No.901-2/2		操作パネルユニット (Operation panel unit)												
PARTS CODE	AR-5623 AR-5620		AR-5618		AR-5623D			AR-5623DA	AR-5620D AR-5618D	AR-5620SL				
	ALL	Philippines	Other	Mexico, LAG2	Philippines	Other	Argentina	ALL	ALL					
CCAB-0125US65						1st lot	1st lot	1st lot						
CCAB-0125US69				1st lot	1st lot									
CCAB-0125US70		1st lot												
CCAB-0125US71	1st lot		1st lot											

2 操作部 (Operation panel section)

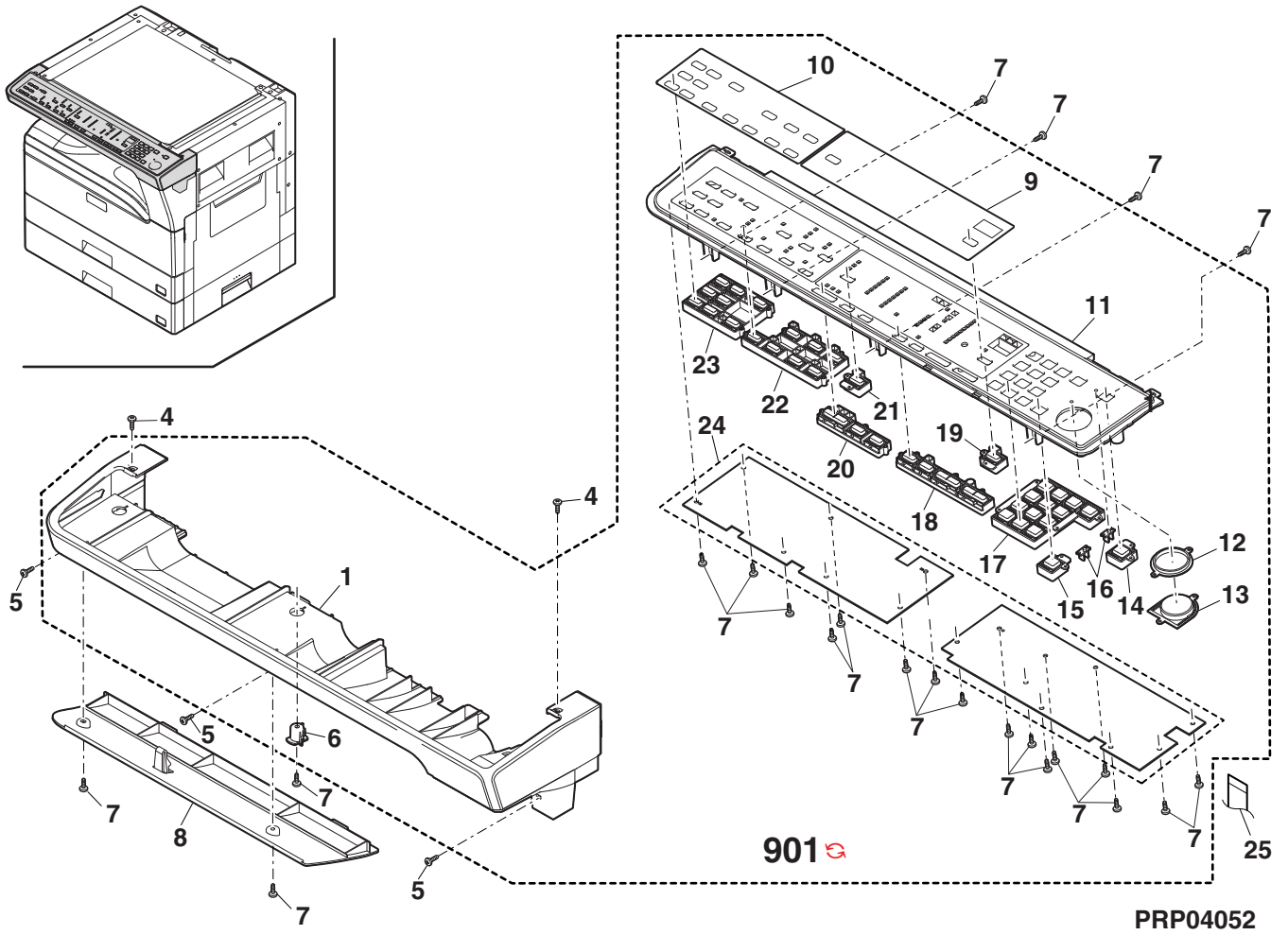

③ サイドユニット (Side door unit)

NO.	PARTS CODE	Inter-change	PRICE RANK		NEW MARK	PART RANK	DESCRIPTION	TR No.	Effective time
			Ex.	Ja.					
1	GDOR-0004QST2		AR	EQ		D	Right door 右ドア		
2	LRALP0004QSZ3		AH	DX		C	Right door rail 右ドアレール		
3	XHBS730P10000		AD	DD		C	Screw(3×10) ビス		
4	LPLTM0092QSZ1		AE	DJ		C	Rail reinforce plate レール補強板		
5	LPLTM0102QSZZ		AD	DJ		C	DUP roller earth plate [AR-5623N/5623D/5623DA/5620N/5620D/5618N/5618D] DUP ローラーアース板		
6	LPLTM0091QSZ1		AE	DJ		C	Inner reinforce plate R インナー補強板 R		
7	XEBS730P10000		AC	DD		C	Screw(3×10) ビス		
8	LPLTM0090QSZ1		AE	DJ		C	Inner reinforce plate F インナー補強板 F		
9	MSPRC0085QSZZ		AE	DJ		C	TC case GND spring TC ケース GND スプリング		
10	LFRM-0016QSZ7		AQ	EQ		D	Right door inner N 右ドアインナー N		
11	XHBS730P16000		AA	DD		C	Screw(3×16) ビス		
12	MSPRT0141GCA1		AB	DJ		C	FU-PSV spring(Refer to Matrix) FU-PSVスプリング		
13	MSPRC0084QSZ1		AD	DJ		C	BC interface electrode spring BC 中継電極 スプリング		
14	MSPRC0083QSZ1		AD	DJ		C	TC interface electrode spring TC 中継電極 スプリング		
15	LHLDZ0033QSZ2		AD	DJ		C	TC terminal interface holder TC 端子中継ホルダー		
16	MSPRC0082QSZ1		AC	DJ		C	Transfer pressure spring 転写圧接用スプリング		
17	NRÖLP1122FCZZ		AF	DS		C	PS upper roller [AR-5623N/5623D/5623DA/5620N/5620D/5618N/5618D] PS 上ローラー		
19	LSUPP0003QSZ1		AD	DJ		C	Right door roller rib [AR-5623N/5623D/5623DA/5620N/5620D/5618N/5618D] 右ドアローラーリブ		
20	NGERH0074QSZZ		AD	DJ		C	DUP roller drive gear [AR-5623N/5623D/5623DA/5620N/5620D/5618N/5618D] DUP ローラー駆動ギヤ		
21	NRÖLP0036QSZZ		AP	EQ		C	DUP transport roller(Refer to Matrix) DUP 搬送ローラー		
21	NRÖLP0036QSZ1	1	AL	EB		C	DUP transport roller(Refer to Matrix) DUP 搬送ローラー		
22	LBSHZ0303FCZZ		AC	DJ		C	M bushing C Mブッシング C		
23	XRESP40-06000		AA	DD		C	E type ring(E4) Eリング		
24	XPSSJ20-07000		AA	DD		C	Spring pin スプリングピン		
25	MSPRC0319QSZZ		AB	DJ		C	Right door knob spring 右ドアノブスプリング		
26	JKNBZ0008QST1		AF	DS		C	Right door knob 右ドアノブ		
	(Unit)								
901	CDOR-0004RS59		BA	FX		E	Side door unit(Refer to Matrix) サイドドアユニット		
901	CDOR-0004US59	1	BF	GN	N	E	Side door unit(Refer to Matrix) サイドドアユニット		
901	CDOR-0004RS60		BC	GD		E	Side door unit(Refer to Matrix) サイドドアユニット		
901	CDOR-0004US60	1	BG	GT	N	E	Side door unit(Refer to Matrix) サイドドアユニット		

Matrix

No.12	FU-PSV スプリング (FU-PSV spring)												
PARTS CODE	AR-5623N			AR-5620N			AR-5618N			AR-5623D AR-5620D AR-5618D		AR-5623DA	
	Germany, Switzerland, France, Spain, Italy	India, Singapore, Malaysia, Vietnam	Australia, New Zealand	Other	Germany, Switzerland, France, Spain, Italy	India, Malaysia, Vietnam	Australia, New Zealand	Other	Germany, Switzerland, France, Spain, Italy	India, Singapore, Malaysia, Vietnam	Other	ALL	Argentina
MSPRT0141GCA1	1st lot	1st lot	1st lot		1st lot	1st lot	1st lot		1st lot	1st lot			

③ サイドドアユニット (Side door unit)

Matrix

No.21-1/2		DUP 搬送ローラー (DUP transport roller)													
PARTS CODE	AR-5623N					AR-5620N					AR-5618N				
	Germany, Switzerland, France, Spain, Italy	India, Singapore, Malaysia, Vietnam	Australia, New Zealand	Russia	Other	Germany, Switzerland, France, Spain, Italy	India, Malaysia, Vietnam	Australia, New Zealand	Philippines	Other	Germany, Switzerland, France, Spain, Italy	India, Singapore, Malaysia, Vietnam	Russia	Other	
NR0LP0036QSZZ	1st lot	1st lot	1st lot		1st lot	1st lot	1st lot		1st lot		1st lot	1st lot		1st lot	
NR0LP0036QSZ1	Mar/11	Mar/11	Mar/11	1st lot	May/11	Mar/11	Mar/11	Mar/11	1st lot	May/11	Mar/11	Mar/11	1st lot	May/11	

No.21-2/2		DUP 搬送ローラー (DUP transport roller)													
PARTS CODE	AR-5623D	AR-5620D	AR-5618D	AR-5623DA											
	ALL	Argentina													
NR0LP0036QSZ1	1st lot	1st lot													

No.901-1/2		サイドドアユニット (Side door unit)														
PARTS CODE	AR-5623N					AR-5620N					AR-5618N				AR-5620S AR-5618S	
	Germany, Switzerland, France, Spain, Italy, Australia, New Zealand	India, Singapore, Malaysia, Vietnam	Other	Germany, Switzerland, France, Spain, Italy, Australia, New Zealand	India, Malaysia, Vietnam	Other	Germany, Switzerland, France, Spain, Italy	India, Singapore, Malaysia, Vietnam	Other	India, Germany, Switzerland, France	Lebanon, Nigeria, Algeria, Egypt, Jordan, Tunisia, Morocco	Other				
CD0R-0004RS59										1st lot	1st lot					
CD0R-0004US59										Apr/11	Apr/11	1st lot				
CD0R-0004RS60	1st lot	1st lot		1st lot	1st lot		1st lot	1st lot								
CD0R-0004US60	Apr/11	Apr/11	1st lot	Apr/11	Apr/11	1st lot	Apr/11	Apr/11	1st lot							

No.901-2/2		サイドドアユニット (Side door unit)													
PARTS CODE	AR-5623	AR-5620	AR-5618	AR-5620SL	AR-5623D	AR-5620D	AR-5618D	AR-5623DA							
	ALL	ALL	ALL	Argentina											
CD0R-0004US59	1st lot	1st lot													
CD0R-0004US60			1st lot	1st lot											

③ サイドドアユニット (Side door unit)

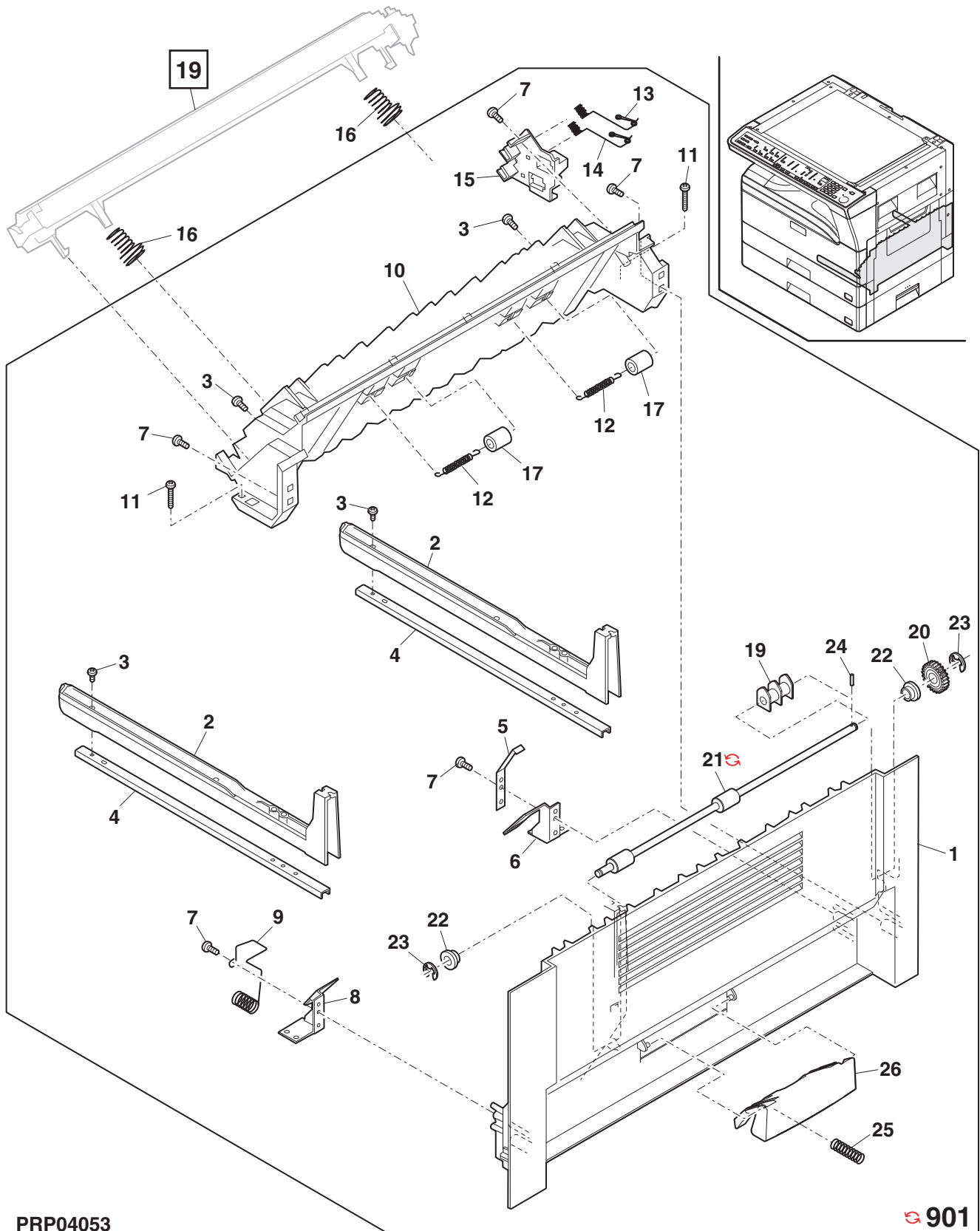

PRP04053

901

4 光学ユニット1(Optical unit 1)

NO.	PARTS CODE	Inter-change	PRICE RANK		NEW MARK	PART RANK	DESCRIPTION	TR No.	Effective time
			Ex.	Ja.					
1	PCASZ0014QSZZ		BN	LE		D	Dark box(Refer to Matrix)		
	PCASZ0010QSZZ		AL	EB		D	Dark box(Refer to Matrix)		
2	XHBS730P06000		AC	DD		C	Screw(3×6)		
3	DHAi-0342QSZZ		AG	DX		C	CCD harness		
4	RCORF0018QSZZ		AR	EQ		C	Core		
5	PTPE-0050QSZZ		AA	DJ		C	Core fixing tape		
6	XHBS730P06KS0		AC	DD		C	Screw(3×6KS)		
7	CLNS-0017RS51		BK	HC		E	Lens unit(Refer to Matrix)		
	CLNS-0017US51	1	BM	HR	N	E	Lens unit(Refer to Matrix)		
16	PSHEZ0217QSZZ		AC	DJ		C	CCD harness protect mylar B		
19	PGUMS0004QSZZ		AA	DJ		C	Table glass rubber		
20	LHLDZ0104QSZZ		AD	DJ		C	CL lead holder		
21	PSHEZ0426QSZZ		AB	DJ		C	OP harness protect mylar B		
	PSHEZ0426QSZZ	-	AB	DJ		C	OP harness protect mylar B		11/08R/C
22	PSHEZ0468QSZZ		AB	DJ		C	Optical right hole mylar A		
23	PSHEZ0631QSZZ		AA	DJ		C	Optical mylar CHN		
24	PSHEZ0420QSZZ		AC	DJ		C	OP harness protect mylar		
26	PSHEZ0448QSZZ		AA	DJ		C	Optical base plate bottom mylar A		
	PSHEZ0448QSZZ	-	AA	DJ		C	Optical base plate bottom mylar A		11/06 R/C
28	PSHEZ0273QSZZ		AB	DJ		C	CCD harness fixing mylar(Refer to Matrix)		
	PSHEZ0273QSZ1		AC	DJ		C	CCD harness fixing mylar(Refer to Matrix)		
29	PTPE-0051QSZZ		AC	DJ		C	OP harness fixing tape		
37	PMLT-0033QSZZ		AC	DJ		C	Optical cushion D		
39	PSHEZ0440QSZZ		AC	DJ		C	Optical front hole mylar		
49	XBBS730P08000		AA	DD		C	Screw(3×8)		
50	CPWBF0147QSF8		AL	EB		E	MHPS PWB(Refer to Matrix)		
	CPWBF0191US62		AR	EQ		E	MHPS PWB(Refer to Matrix)		
58	PMLT-0136QSZZ		AC	DJ		C	Optical cushion CHN		
	(Unit)								
901	DUNT-0829US15		BZ	TF	N	E	Optical unit(Refer to Matrix) [Include[2]-25,[5],[6],[7]] 光学ユニット		

Matrix

No.1	暗箱 (Dark box)																			
PARTS CODE	AR-5623N	AR-5620N	AR-5618N	AR-5620S	AR-5618S	AR-5623	AR-5620	AR-5618	AR-5623D	AR-5620D	AR-5618D	AR-5623DA	AR-5620SL							
	ALL	ALL	ALL	ALL	ALL	ALL	ALL	ALL	ALL	ALL	ALL	Argentina	ALL							
PCASZ0014QSZZ	1st lot	1st lot	1st lot	1st lot	1st lot	1st lot	1st lot	1st lot	1st lot	1st lot	1st lot	1st lot	1st lot							
PCASZ0010QSZZ																				

4 光学ユニット1(Optical unit 1)

Matrix

No.7-1/2	レンズユニット (Lens unit)														
PARTS CODE	AR-5623N				AR-5620N				AR-5618N			AR-5620S AR-5618S			
	Germany, Switzerland, France, Spain, Italy	India, Singapore, Malaysia, Vietnam	Australia, New Zealand	Other	Germany, Switzerland, France, Spain, Italy	India, Malaysia, Vietnam	Australia, New Zealand	Other	Germany, Switzerland, France, Spain, Italy	India, Singapore, Malaysia, Vietnam	Other	Germany, Switzerland, France	India	Lebanon, Nigeria, Algeria, Egypt, Jordan, Tunisia, Morocco	Other
CLNS-0017RS51	1st lot	1st lot	1st lot		1st lot	1st lot	1st lot		1st lot	1st lot		1st lot	1st lot	1st lot	
CLNS-0017US51	Apr/11	Apr/11	Apr/11	1st lot	Apr/11	Apr/11	Apr/11	1st lot	Apr/11	Apr/11	1st lot	Apr/11	Apr/11	Apr/11	1st lot

No.7-2/2	レンズユニット (Lens unit)											
PARTS CODE	AR-5623 AR-5620 AR-5618	AR-5623D AR-5620D AR-5618D	AR-5623DA	AR-5620SL								
	ALL	ALL	Argentina	ALL								
CLNS-0017US51	1st lot	1st lot	1st lot									

No.28-1/2	CCDハーネス押えマイラー (CCD harness fixing mylar)														
PARTS CODE	AR-5623N				AR-5620N				AR-5618N			AR-5620S AR-5618S			
	Germany, Switzerland, France, Spain, Italy	India, Singapore, Malaysia, Vietnam	Australia, New Zealand	Other	Germany, Switzerland, France, Spain, Italy	India, Malaysia, Vietnam	Australia, New Zealand	Other	Germany, Switzerland, France, Spain, Italy	India, Singapore, Malaysia, Vietnam	Other	Germany, Switzerland, France	India	Lebanon, Nigeria, Algeria, Egypt, Jordan, Tunisia, Morocco	Other
PSHEZ0273QSZZ	1st lot	1st lot	1st lot		1st lot	1st lot	1st lot		1st lot	1st lot		1st lot	1st lot	1st lot	
PSHEZ0273QSZ1				1st lot				1st lot			1st lot				1st lot

No.28-2/2	CCDハーネス押えマイラー (CCD harness fixing mylar)											
PARTS CODE	AR-5623 AR-5620 AR-5618	AR-5623D AR-5620D AR-5618D	AR-5623DA	AR-5620SL								
	ALL	ALL	Argentina	ALL								
PSHEZ0273QSZ1	1st lot	1st lot	1st lot	1st lot								

4 光学ユニット1(Optical unit 1)

Matrix

No.50-1/2		MHPS 基板 (MHPS PWB)													
PARTS CODE	AR-5623N				AR-5620N				AR-5618N			AR-5620S AR-5618S			
	Germany, Switzerland, France, Spain, Italy	India, Singapore, Malaysia, Vietnam	Australia, New Zealand	Other	Germany, Switzerland, France, Spain, Italy	India, Malaysia, Vietnam	Australia, New Zealand	Other	Germany, Switzerland, France, Spain, Italy	India, Singapore, Malaysia, Vietnam	Other	Germany, Switzerland, France	India	Lebanon, Nigeria, Algeria, Egypt, Jordan, Tunisia, Morocco	Other
CPWBF0147QSF8	1st lot	1st lot	1st lot		1st lot	1st lot	1st lot		1st lot	1st lot		1st lot	1st lot	1st lot	
CPWBF0191US62				1st lot				1st lot			1st lot				1st lot

No.50-2/2		MHPS 基板 (MHPS PWB)													
PARTS CODE	AR-5623	AR-5620	AR-5618	AR-5623D	AR-5620D	AR-5618D	AR-5623DA	AR-5620SL							
	ALL	ALL	ALL	ALL	ALL	ALL	Argentina	ALL							
CPWBF0191US62	1st lot	1st lot	1st lot	1st lot	1st lot										

No.901-1/2		光学サブユニット (Optical sub unit)													
PARTS CODE	AR-5623N				AR-5620N				AR-5618N			AR-5620S AR-5618S			
	Germany, Switzerland, France, Spain, Italy	India, Singapore, Malaysia, Vietnam	Australia, New Zealand	Other	Germany, Switzerland, France, Spain, Italy	India, Malaysia, Vietnam	Australia, New Zealand	Other	Germany, Switzerland, France, Spain, Italy	India, Singapore, Malaysia, Vietnam	Other	Germany, Switzerland, France	India	Lebanon, Nigeria, Algeria, Egypt, Jordan, Tunisia, Morocco	Other
DUNT-0829US15				1st lot				1st lot			1st lot				1st lot

No.901-2/2		光学サブユニット (Optical sub unit)													
PARTS CODE	AR-5623	AR-5620	AR-5618	AR-5623D	AR-5620D	AR-5618D	AR-5623DA	AR-5620SL							
	ALL	ALL	ALL	ALL	ALL	ALL	Argentina	ALL							
DUNT-0829US15	1st lot	1st lot	1st lot	1st lot	1st lot	1st lot									

4 光学ユニット 1(Optical unit 1)

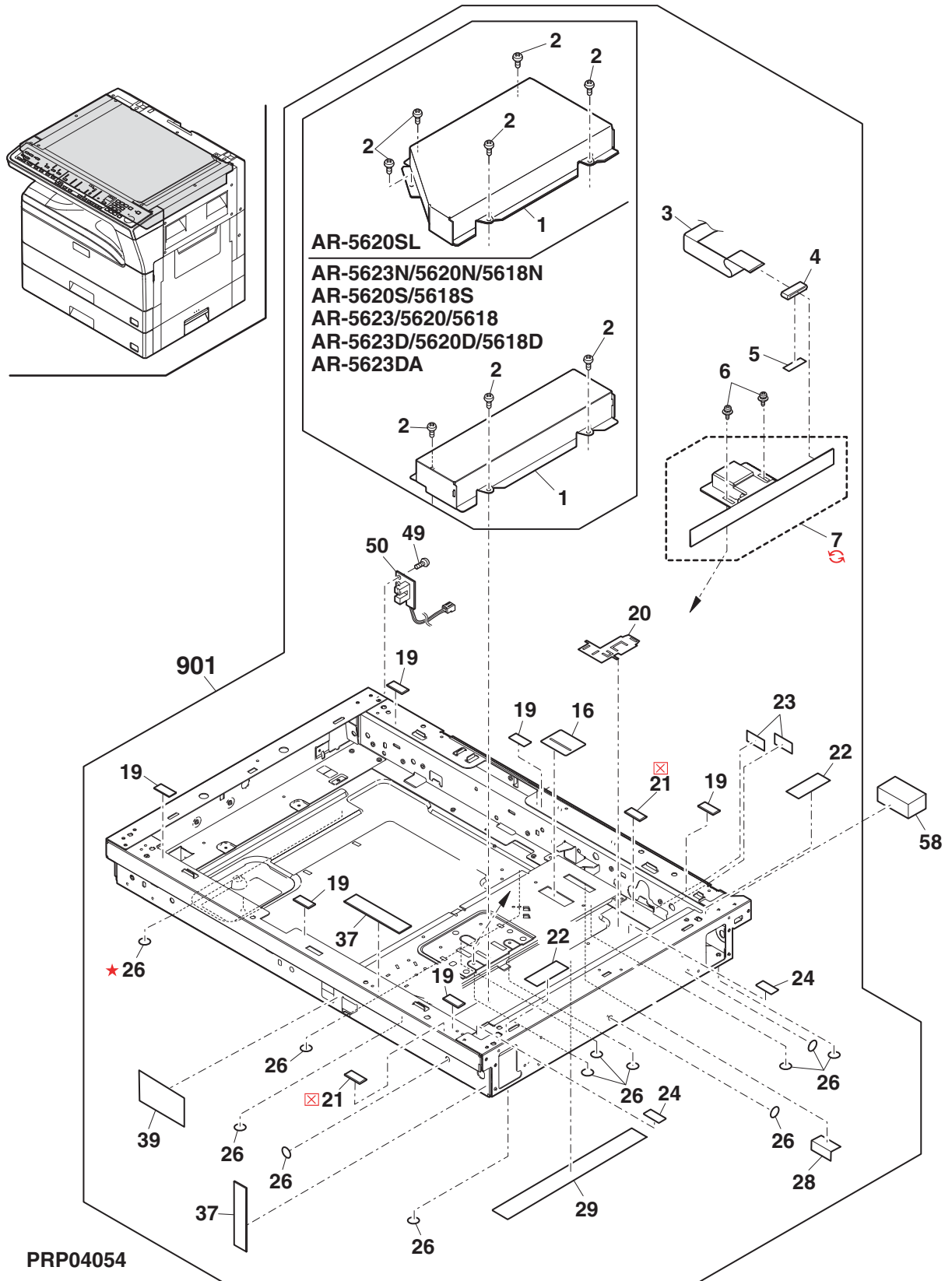

5 光学ユニット2(Optical unit 2)

NO.	PARTS CODE	Inter-change	PRICE RANK		NEW MARK	PART RANK	DESCRIPTION	TR No.	Effective time
			Ex.	Ja.					
1	PWIR-0006QSPZ		AZ	FQ		C	MB wire F	MB ワイヤ F	
3	PWIR-0005QSP1		AZ	FQ		C	MB wire R	MB ワイヤ R	
4	LHLDZ0109QSZZ		AD	DJ		C	Wire holder	ワイヤホルダー	
5	XBPS740P06K00		AA	DD		C	Screw(4x6K)	ビス	
6	NPLYZ0006QSZ1		AD	DJ		C	L pulley	Lプーリー	
7	NPLYZ0016QSZZ		AF	DS		C	Constant pulley	定プーリー	
8	XRESP40-05000		AA	DD		C	E type ring(E4)	Eリング	
10	MSPRT0393QSZZ		AD	DJ		C	Mirror spring(Refer to Matrix)	ミラー Spring リング	
13	RMOTS0041QSPZ		BA	FX		B	Mirror motor	ミラーモーター	
14	XHBS730P06000		AC	DD		C	Screw(3x6)	ビス	
15	CPLTM0430QS02		AH	DX		C	Mirror motor fixing plate	ミラーモーター取付板	
16	XRESP50-06000		AA	DD		C	E type ring(E5)	Eリング	
17	NBRGP0012QSZZ		AC	DJ		C	Winder bearing R	巻取り軸受 R	
18	NBLTT0037QSZZ		AL	EB		B	Winder drive belt	巻取り駆動ベルト	
19	NGERH0165QSZZ		AE	DJ		C	Mirror motor idle gear	ミラーモーターアイドルギヤ	
20	LSTPP0011QSZZ		AC	DJ		C	Stopper	ストッパー	
22	NPLYZ0032QSZZ		AK	DX		C	Winder drive shaft pulley	巻取り駆動軸プーリー	
23	LX-BZ0039FCZZ		AB	DD		C	Screw(4x4)	ビス	
24	LPFTF0004QSZZ		AB	DJ		C	Winder flange	巻取りフランジ	
25	LX-BZ0049FCPZ		AB	DD		C	Screw(4x6)	ビス	
26	LX-BZ0324FCPZ		AA	DD		C	Screw(3x4)	ビス	
27	NPLYZ0031QSZZ		AL	EB		C	Winder pulley	巻取りプーリー	
28	NSFTZ0071QSPZ		AQ	EQ		C	Winder drive shaft	巻取り駆動軸	
29	NBRGP0011QSZZ		AC	DJ		C	Winder bearing F	巻取り軸受 F	
30	XRESP70-08000		AA	DD		C	E type ring(E7)	Eリング	
31	LX-BZ0004QSPZ		AB	DD		C	Screw(3x6 Red)	ビス	
32	LRALM0007QSZZ		AG	DS		C	MB-B rail R	MB-B レール R	
33	LRALM0006QSZZ		AF	DS		C	MB-B rail F	MB-B レール F	
34	LBNDJ0043FCP1		AB	DJ		C	Band	バンド	

Matrix

No.10-1/2	ミラー Spring リング (Mirror spring)															
PARTS CODE	AR-5623N				AR-5620N				AR-5618N				AR-5620S AR-5618S			
	Germany, Switzerland, France, Spain, Italy	India, Singapore, Malaysia, Vietnam	Australia, New Zealand	Other	Germany, Switzerland, France, Spain, Italy	India, Malaysia, Vietnam	Australia, New Zealand	Other	Germany, Switzerland, France, Spain, Italy	India, Singapore, Malaysia, Vietnam	Other	Germany, Switzerland, France	India	Lebanon, Nigeria, Algeria, Egypt, Jordan, Tunisia, Morocco	Other	
MSPRT0393QSZZ	1st lot	1st lot	1st lot		1st lot	1st lot	1st lot		1st lot	1st lot		1st lot	1st lot	1st lot		

No.10-2/2	ミラー Spring リング (Mirror spring)														
PARTS CODE	AR-5623	AR-5620	AR-5618	AR-5623D	AR-5620D	AR-5618D	AR-5623DA	AR-5620SL							
	ALL	ALL	ALL	ALL	ALL	ALL	Argentina	ALL							

5 光学ユニット2(Optical unit 2)

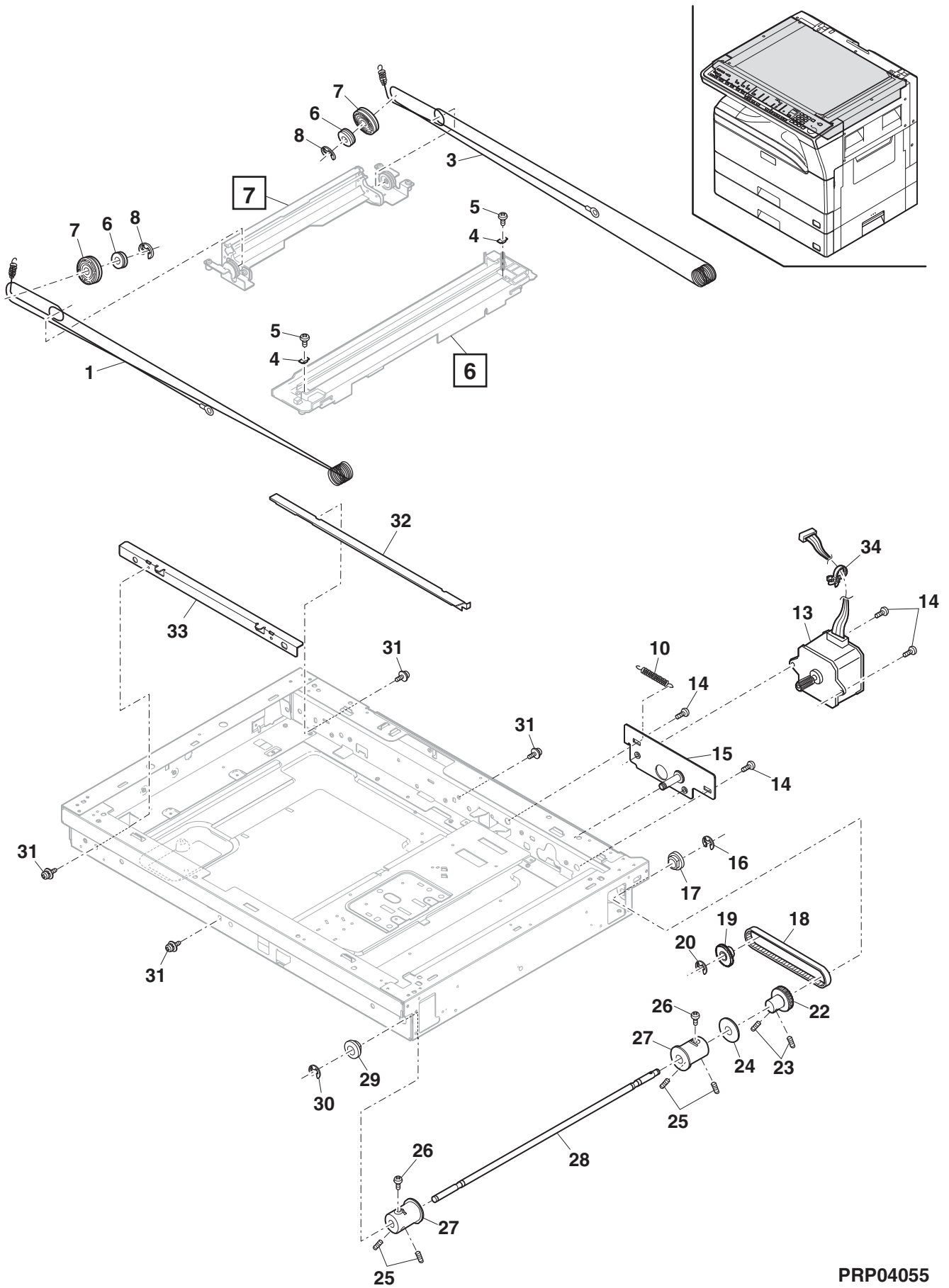

PRP04055

6 ランプユニット (Lamp unit)

NO.	PARTS CODE	Inter-change	PRICE RANK		NEW MARK	PART RANK	DESCRIPTION	TR No.	Effective time
			Ex.	Ja.					
1	PREFL0006QSZZ		AK	DX		C	Sub reflector(Refer to Matrix)		
	PREFL0006QSZ1		AK	DX		C	Sub reflector(Refer to Matrix)		
2	XEBS830P06000		AB	DD		C	Screw(3×6)		
	XEBS730P06000	1	AA	DD		C	Screw(3×6)		11/04
3	PREFL0005QSZZ		AH	DX		C	Lamp reflector		
4	RLMPD0033QSZZ		AS	EQ		B	Lamp(Refer to Matrix)		
	RLMPD0034QSZZ		AS	EQ		B	Lamp(Refer to Matrix)		
5	TLABZ4335FCZZ		AB	DJ		D	High temperature caution label		
6	MSLi-0138FCZZ		AC	DJ		C	Slider		
7	PCUSU0203FCZZ		AE	DS		C	Vibration proof cushion		
8	MSPRP2825FCZZ		AC	DJ		C	Mirror spring		
9	LDAiU0030QSZZ		AS	EQ		D	Lamp base		
10	PCUSS0033QSZZ		AC	DJ		C	Mirror cushion N		
11	LPLTM0314QSZ1		AC	DJ		C	Wire support plate		
12	PMiR-0164FCZZ		AP	EQ		B	1st mirror		
13	LFiX-0023QSZZ		AC	DJ		C	Harness fixing plate		
14	DHAi-0332QSZZ		AE	DJ		C	CL harness		
15	RiNV-0002QSZZ		AU	EZ		E	Inverter(Refer to Matrix)		
	RiNV-0003QSZZ		BF	GN		E	Inverter(Refer to Matrix)		
16	PSHEZ0465QSZZ		AC	DJ		C	Lamp mylar [AR-5620SL]		
(Unit)									
901	CREFL0005RS65		BC	GD		E	Copy Lamp unit(Refer to Matrix)		
	CREFL0005US62		BE	GN		E	Copy Lamp unit(Refer to Matrix)		

Matrix

No.1	サブリフレクター (Sub reflector)																		
PARTS CODE	AR-5623N	AR-5620N	AR-5618N	AR-5620S	AR-5618S	AR-5623	AR-5620	AR-5618	AR-5623D	AR-5620D	AR-5618D	AR-5623DA	AR-5620SL						
PREFL0006QSZZ	1st lot	1st lot	1st lot	1st lot	1st lot	1st lot	1st lot	1st lot	1st lot	1st lot	1st lot	1st lot	1st lot						
PREFL0006QSZ1													1st lot						

No.4	ランプ (Lamp)																		
PARTS CODE	AR-5623N	AR-5620N	AR-5618N	AR-5620S	AR-5618S	AR-5623	AR-5620	AR-5618	AR-5623D	AR-5620D	AR-5618D	AR-5623DA	AR-5620SL						
RLMPD0033QSZZ	1st lot	1st lot	1st lot	1st lot	1st lot	1st lot	1st lot	1st lot	1st lot	1st lot	1st lot	1st lot	1st lot						
RLMPD0034QSZZ													1st lot						

No.15-1/2	インバーター (Inverter)																		
PARTS CODE	AR-5623N			AR-5620N				AR-5618N			AR-5620S AR-5618S								
	Germany, Switzerland, France, Spain, Italy	India, Singapore, Malaysia, Vietnam	Australia, New Zealand	Other	Germany, Switzerland, France, Spain, Italy	India, Malaysia, Vietnam	Australia, New Zealand	Other	Germany, Switzerland, France, Spain, Italy	India, Singapore, Malaysia, Vietnam	Other	Germany, Switzerland, France	India	Lebanon, Nigeria, Algeria, Egypt, Jordan, Tunisia, Morocco	Other				
RiNV-0002QSZZ	1st lot	1st lot	1st lot		1st lot	1st lot	1st lot	1st lot	1st lot	1st lot	1st lot	1st lot	1st lot	1st lot	1st lot	1st lot	1st lot	1st lot	1st lot
RiNV-0003QSZZ				1st lot				1st lot				1st lot							1st lot

⑥ ランプユニット (Lamp unit)

Matrix

No.15-2/2		インバーター (Inverter)												
PARTS CODE	AR-5623 AR-5620 AR-5618	AR-5623D AR-5620D AR-5618D	AR-5623DA	AR-5620SL										
	ALL				ALL	Argentina	ALL							
RiNV-0003QSZZ	1st lot	1st lot	1st lot	1st lot										

No.901-1/2		コピーランプユニット (Copy Lamp unit)													
PARTS CODE	AR-5623N			AR-5620N			AR-5618N			AR-5620S AR-5618S					
	Germany, Switzerland, France, Spain, Italy	India, Singapore, Malaysia, Vietnam	Australia, New Zealand	Other	Germany, Switzerland, France, Spain, Italy	India, Malaysia, Vietnam	Australia, New Zealand	Other	Germany, Switzerland, France, Spain, Italy	India, Singapore, Malaysia, Vietnam	Other	Germany, Switzerland, France	India	Lebanon, Nigeria, Algeria, Egypt, Jordan, Tunisia, Morocco	Other
CREFL0005RS65	1st lot	1st lot	1st lot		1st lot	1st lot	1st lot		1st lot	1st lot		1st lot	1st lot	1st lot	
CREFL0005US62				1st lot				1st lot				1st lot			1st lot

No.901-2/2		コピーランプユニット (Copy Lamp unit)												
PARTS CODE	AR-5623 AR-5620 AR-5618	AR-5623D AR-5620D AR-5618D	AR-5623DA	AR-5620SL										
	ALL				ALL	Argentina	ALL							
CREFL0005US62	1st lot	1st lot	1st lot											

6 ランプユニット (Lamp unit)

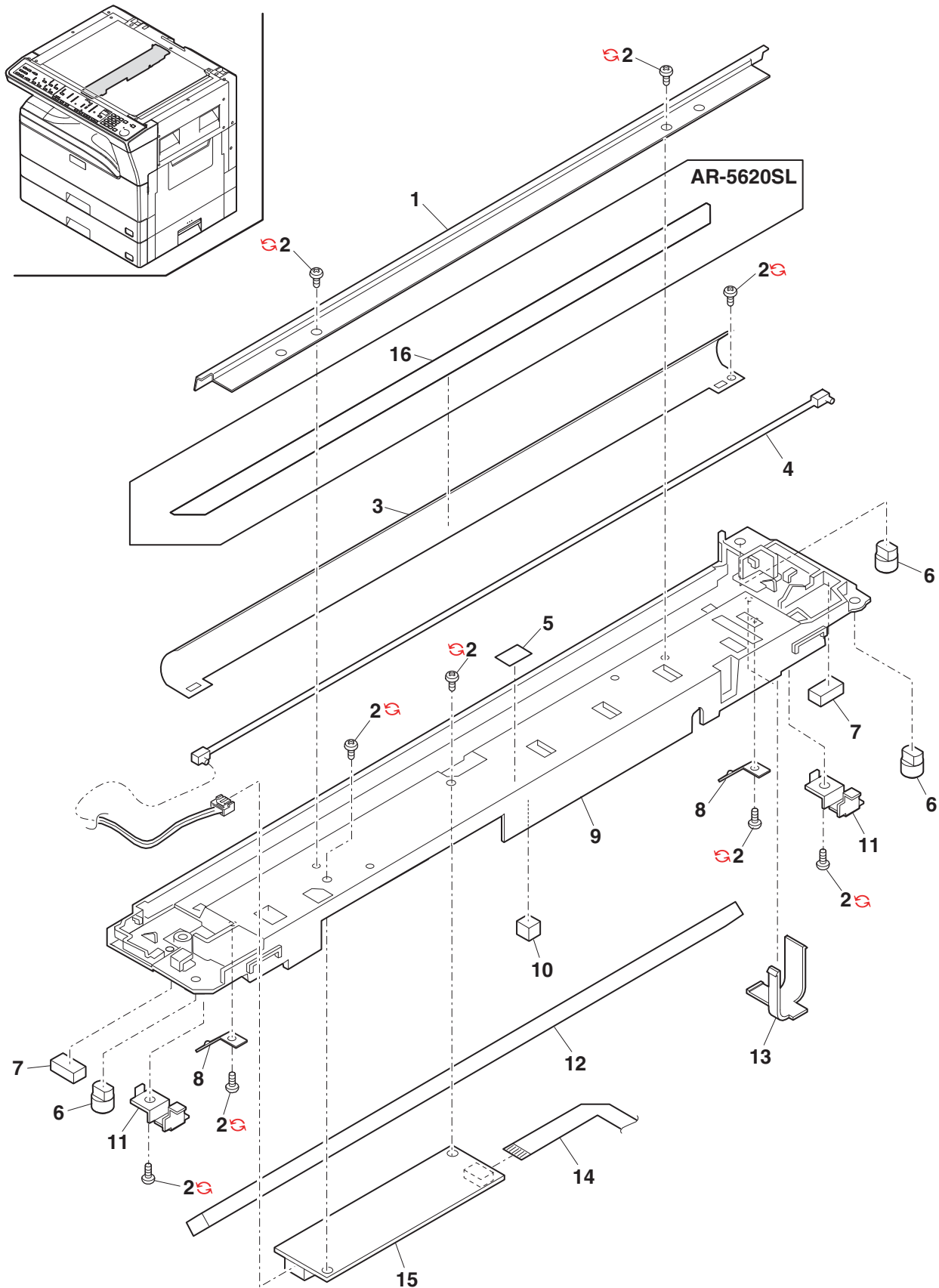

7 第 2,3 ミラーユニット (2nd,3rd mirror unit)

NO.	PARTS CODE	Inter-change	PRICE RANK		NEW MARK	PART RANK	DESCRIPTION	TR No.	Effective time
			Ex.	Ja.					
1	LHLDZ0044QSZZ		AN	EG		C	2nd,3rd mirror holder		第 2,3 ミラーホルダー
3	XBPS740P06KS0		AB	DD		C	Screw(4x6KS)		ビス
4	NPLYZ0017QSZZ		AE	DS		C	W pulley		Wプーリー
5	LHLDZ0013QSZZ		AD	DJ		C	CL guide holder		CLガイドホルダー
7	MSL i-0138FCZZ		AC	DJ		C	Slider		スベリ材
8	LX-BZ0335FCPZ		AB	DD		C	Screw(4x6 Red)		ビス
9	CPLTM0156QS03		AH	DX		C	Pulley fixing plate R		プーリー取付板 R
10	PCUSS0009QSZZ		AA	DJ		C	MB-B cushion R		MB-Bクッション R
11	LF i X-0284FCZZ		AC	DD		C	2nd,3rd mirror fixing plate F		第 2,3 ミラー押え板 F
12	PM i R-0008QSZ1		BA	FX		B	2nd,3rd mirror		第 2,3 ミラー
13	CPLTM0155QS03		AH	DX		C	Pulley fixing plate F		プーリー取付板 F
14	PCUSS0201FCZZ		AA	DD		C	MB-B cushion		MB-Bクッション
15	PSPAZ0011QSZZ		AD	DJ		C	Mirror spacer		ミラースペーサー
16	PMLT-0084QSZZ		AB	DJ		C	2nd,3rd mirror cushion		第 2,3 ミラーモルト
17	LX-WZ0001GCZZ		AB	DD		C	Washer		ワッシャー
	(Unit)								
901	CM i R-0008QS37		BA	FX		E	2nd,3rd mirror unit(Refer to Matrix)		第 2,3 ミラーユニット
	CM i R-0008US37		AX	FG		E	2nd,3rd mirror unit(Refer to Matrix)		第 2,3 ミラーユニット

Matrix

No.901-1/2	第 2,3 ミラーユニット (2nd,3rd mirror unit)														
PARTS CODE	AR-5623N				AR-5620N				AR-5618N			AR-5620S AR-5618S			
	Germany,Switzerland, France,Spain,Italy	India,Singapore, Malaysia,Vietnam	Australia, New Zealand	Other	Germany,Switzerland, France,Spain,Italy	India, Malaysia,Vietnam	Australia, New Zealand	Other	Germany,Switzerland, France,Spain,Italy	India,Singapore, Malaysia,Vietnam	Other	Germany, Switzerland,France	India	Lebanon,Nigeria, Algeria,Egypt,Jordan, Tunisia,Morocco	Other
CM i R-0008QS37	1st lot	1st lot	1st lot		1st lot	1st lot	1st lot		1st lot	1st lot		1st lot	1st lot	1st lot	
CM i R-0008US37				1st lot				1st lot			1st lot				1st lot

No.901-2/2	第 2,3 ミラーユニット (2nd,3rd mirror unit)										
PARTS CODE	AR-5623	AR-5620	AR-5618	AR-5623D	AR-5620D	AR-5618D	AR-5623DA	AR-5620SL			
	ALL	ALL	ALL	ALL	ALL	ALL	Argentina	ALL			
CM i R-0008US37	1st lot	1st lot	1st lot	1st lot	1st lot	1st lot	1st lot	1st lot			

7 第 2,3 ミラ-ユニット (2nd,3rd mirror unit)

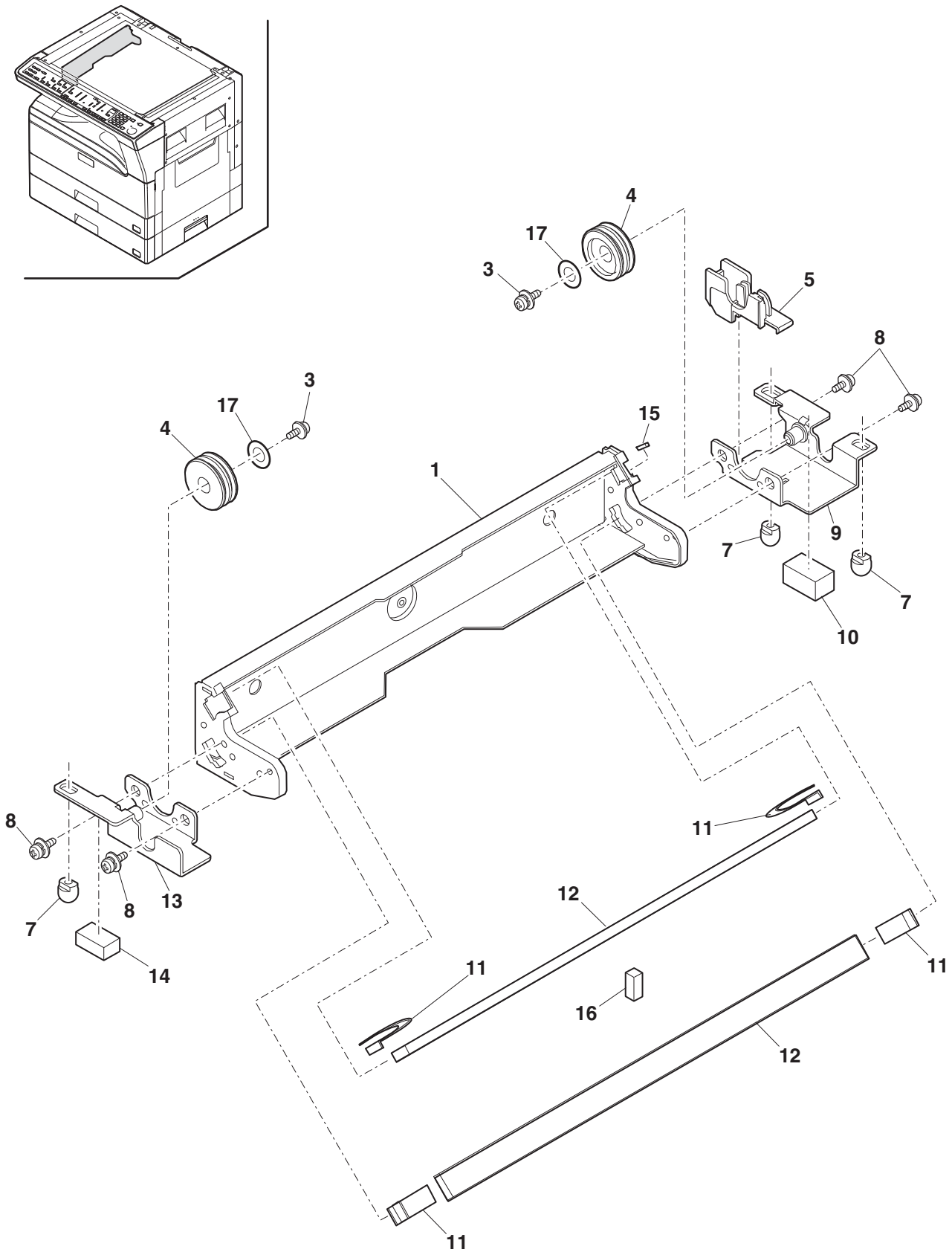

PRP04057

8 中間フレームユニット (Middle frame unit)

NO.	PARTS CODE	Inter-change	PRICE RANK		NEW MARK	PART RANK	DESCRIPTION	TR No.	Effective time
			Ex.	Ja.					
1	XEPS723P12000		AA	DD		C	Screw(2.3×12)	ビス	
2	CSW-M0007RS57		AQ	EQ	N	B	Interlock switch(Refer to Matrix)	インターロック SW	
	CSW-M0007US57		AT	EZ	N	B	Interlock switch(Refer to Matrix)	インターロック SW	
3	NCPL-0007QSZ1		AC	DJ		C	Hopper coupling	ホッパー-カップ リング	
4	MSPRC0024QSZ1		AC	DJ		C	Hopper spring	ホッパー-スプリング	
5	RMOTD0035QSP1		AZ	FX		B	Toner motor	トナーモーター	
6	XEBS730P10000		AC	DD		C	Screw(3×10)	ビス	
7	DUNTK0959QSZZ		BV	NU		E	LSU UN	LSU UN	
8	DHAi-0322QSZZ		AS	EQ		C	DEV harness	DEV ハーネス	
9	XBPSC30P06ES0		AA	DD		C	Screw(3×6)	ビス	
10	CHAi-0109RS52		AN	EG		C	GB-MCFB harness unit(Refer to Matrix)	GB-MCFB ハーネスユニット	
	CHAi-0109US52		AG	DS		C	GB-MCFB harness unit(Refer to Matrix)	GB-MCFB ハーネスユニット	
11	CHAi-0107RS52		AM	EG		C	MC harness unit(Refer to Matrix)	MC ハーネスユニット	
	CHAi-0107US52		AE	DJ		C	MC harness unit(Refer to Matrix)	MC ハーネスユニット	
12	MSPRD0104QSZZ		AC	DJ		C	HV terminal spring (case)	高圧端子スプリング (ケース)	
13	MSPRD0103QSZZ		AC	DJ		C	HV terminal spring (grid)	高圧端子スプリング (グリッド)	
14	MSPRD0102QSZZ		AC	DJ		C	HV terminal spring (saw)	高圧端子スプリング (ノコギリ)	
15	LHLZ0038QSC1		AH	DX		C	HV terminal holder	高圧端子ホルダー	
16	XEBS730P08000		AC	DD		C	Screw(3×8)	ビス	
17	LFRM-0113QSZZ		BN	LE		D	Middle frame	中間フレーム	
21	LHLZ0039QSZ1		AD	DJ		C	HV terminal holder TC	高圧端子ホルダー TC	
22	LPLTM0067QSZZ		AC	DJ		C	TC terminal plate	TC 端子板	
23	XEBS730P06000		AA	DD		C	Screw(3×6)	ビス	
24	DHAi-0550QSPZ		AK	DX		C	BC harness	BC ハーネス	
25	DHAi-0108QSZ1		AH	DX		C	TC harness	TC ハーネス	
26	MSPRC0431QSZZ		AC	DJ		C	PS pressure spring	PS 加圧スプリング	
27	XRESP40-06000		AA	DD		C	E type ring(E4)	E リング	
28	NSFTZ0134QSZZ		AT	EZ		C	PS follower shaft	PS 従動ローラー軸	
29	NKOM-0001QSZZ		AD	DJ		C	PS collar(φ12)	PS コロ	
30	MSPRD0139QSZZ		AB	DJ		C	PS earth spring	PS アーススプリング	
32	LBNDJ0013FCZ1		AE	DJ		C	Cable band	ケーブルバンド	
33	LPLTM0424QSZZ		AD	DJ		C	Connector fixing plate	コネクタ取付板	
34	LX-BZ0020QSPZ		AB	DD		C	Screw	ビス	
35	DHAi-0558QSPZ		AL	EB		C	CRM MCU harness	CRM MCU ハーネス	
36	XHBS730P06000		AC	DD		C	Screw(3×6)	ビス	
37	PSHEZ0625QSZZ		AB	DD		C	PS rear guide sheet CHN	PS 後ガイドシート CHN	
38	NBRGC0018QSZZ		AD	DJ		C	Bearing E	軸受 E	
39	XRESP60-08000		AA	DD		C	E type ring(E6)	E リング	
41	JKNBZ0003QSZZ		AD	DJ		C	PS knob	PS ノブ	
42	XBPS730P10KS0		AB	DD		C	Screw(3×10KS)	ビス	
43	LX-WZ0198FCZ1		AA	DD		C	Poly slider(T=0.13)	ポリスライダ	
44	LSTPP0014QSZZ		AC	DJ		C	Right door stopper	右ドアストップ	
45	MSPRD0298QSZZ		AD	DJ		C	Stopper spring	ストップスプリング	
46	LHLZ0099QSZZ		AC	DJ		C	Stopper holder	ストップホルダー	
47	LPiNS0032QSZZ		AN	EQ		C	TN guide pin D(Refer to Matrix)	TN ガイドピン D	
	LPiNS0034QSZZ		AC	DD		C	TN guide pin C(Refer to Matrix)	TN ガイドピン C	
50	PSHEZ0658QSZZ		AR	EQ		C	Doctor front sheet	ドクター前シート	
52	LPLTM0586QSZZ		AC	DD		C	M3 plate SIR(M3)	M3 プレート SIR	
53	XEPS730P14X00		AB	DD		C	Screw(3×14X)	ビス	
54	DHAi-0554QSPZ		AN	EG		C	LSU MCU harness	LSU MCU ハーネス	
55	PMLT-0135QSZZ		AC	DJ		C	PG cushion	PG モルト	
56	PSHEZ0691QSZZ		AB	DD		C	LSU sheet1	LSU シート 1	
57	PSHEZ0692QSZZ		AB	DD		C	LSU sheet2	LSU シート 2	
58	LPLTM0580QSZZ		BN	LE		C	Middle frame reinforce plate	中間フレーム補強板	
59	MSPRC0339QSZZ	-	AD	DJ		C	PS brake spring	PS ブレーキスプリング	1st lot
60	LX-WZ1003HCZZ	-	AA	DD		C	Poly slider	ポリスライダ	1st lot

8 中間フレームユニット (Middle frame unit)

Matrix

No.2-1/2		インタロック SW(Interlock switch)													
PARTS CODE	AR-5623N			AR-5620N			AR-5618N			AR-5620S AR-5618S					
	Germany, Switzerland, France, Spain, Italy	India, Singapore, Malaysia, Vietnam	Australia, New Zealand	Other	Germany, Switzerland, France, Spain, Italy	India, Malaysia, Vietnam	Australia, New Zealand	Other	Germany, Switzerland, France, Spain, Italy	India, Singapore, Malaysia, Vietnam	Other	Germany, Switzerland, France	India	Lebanon, Nigeria, Algeria, Egypt, Jordan, Tunisia, Morocco	Other
CSW-M0007RS57	1st lot	1st lot	1st lot		1st lot	1st lot	1st lot		1st lot	1st lot		1st lot	1st lot	1st lot	
CSW-M0007US57				1st lot				1st lot							1st lot

No.2-2/2		インタロック SW(Interlock switch)												
PARTS CODE	AR-5623 AR-5620 AR-5618	AR-5623D AR-5620D AR-5618D	AR-5623DA	AR-5620SL										
	ALL	ALL	Argentina	ALL										
CSW-M0007US57	1st lot	1st lot	1st lot	1st lot										

No.10-1/2		GB-MCFB ハーネスユニット (GB-MCFB harness unit)													
PARTS CODE	AR-5623N			AR-5620N			AR-5618N			AR-5620S AR-5618S					
	Germany, Switzerland, France, Spain, Italy	India, Singapore, Malaysia, Vietnam	Australia, New Zealand	Other	Germany, Switzerland, France, Spain, Italy	India, Malaysia, Vietnam	Australia, New Zealand	Other	Germany, Switzerland, France, Spain, Italy	India, Singapore, Malaysia, Vietnam	Other	Germany, Switzerland, France	India	Lebanon, Nigeria, Algeria, Egypt, Jordan, Tunisia, Morocco	Other
CHA i - 0109RS52	1st lot	1st lot	1st lot		1st lot	1st lot	1st lot		1st lot	1st lot		1st lot	1st lot	1st lot	
CHA i - 0109US52				1st lot				1st lot							1st lot

No.10-2/2		GB-MCFB ハーネスユニット (GB-MCFB harness unit)												
PARTS CODE	AR-5623 AR-5620 AR-5618	AR-5623D AR-5620D AR-5618D	AR-5623DA	AR-5620SL										
	ALL	ALL	Argentina	ALL										
CHA i - 0109US52	1st lot	1st lot	1st lot	1st lot										

8 中間フレームユニット (Middle frame unit)

Matrix

No.11-1/2	MC ハーネスユニット (MC harness unit)														
PARTS CODE	AR-5623N			AR-5620N			AR-5618N			AR-5620S AR-5618S					
	Germany, Switzerland, France, Spain, Italy	India, Singapore, Malaysia, Vietnam	Australia, New Zealand	Other	Germany, Switzerland, France, Spain, Italy	India, Malaysia, Vietnam	Australia, New Zealand	Other	Germany, Switzerland, France, Spain, Italy	India, Singapore, Malaysia, Vietnam	Other	Germany, Switzerland, France	India	Lebanon, Nigeria, Algeria, Egypt, Jordan, Tunisia, Morocco	Other
CHA i - 0 1 0 7 R S 5 2	1st lot	1st lot	1st lot		1st lot	1st lot	1st lot		1st lot	1st lot		1st lot	1st lot	1st lot	
CHA i - 0 1 0 7 U S 5 2				1st lot				1st lot			1st lot				1st lot

No.11-2/2	MC ハーネスユニット (MC harness unit)														
PARTS CODE	AR-5623	AR-5620	AR-5618	AR-5623D	AR-5620D	AR-5618D	AR-5623DA	AR-5620SL							
	ALL	ALL	ALL	ALL	ALL	ALL	Argentina	ALL							
CHA i - 0 1 0 7 U S 5 2	1st lot	1st lot	1st lot	1st lot	1st lot										

No.47	TN ガイドピン D (TN guide pin D) TN ガイドピン C (TN guide pin C)														
PARTS CODE	Germany, Switzerland, France, Spain, Italy	Australia, New Zealand	Greece, Cyprus, Turkey, Poland, Hungary, Czech, Slovakia	Russia	Other										
LP i NS 0 0 3 2 Q S Z Z	1st lot	1st lot	1st lot	1st lot											
LP i NS 0 0 3 4 Q S Z Z					1st lot										

8 中間フレームユニット (Middle frame unit)

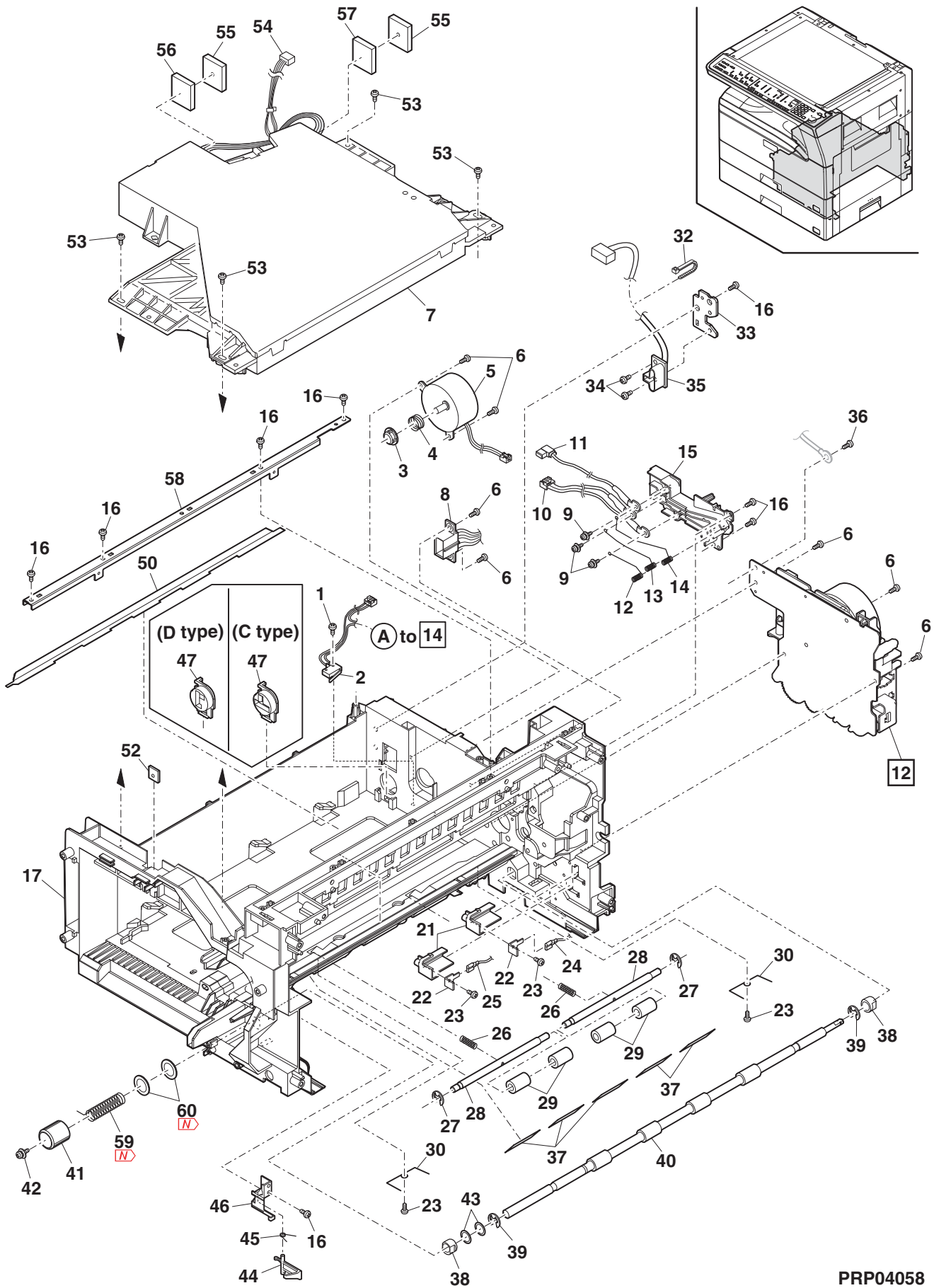

PRP04058

9 プロセッシングユニット (Process unit)

NO.	PARTS CODE	Inter-change	PRICE RANK		NEW MARK	PART RANK	DESCRIPTION	TR No.	Effective time
			Ex.	Ja.					
1	XEBS730P10000		AC	DD		C	Screw(3×10)		ビス
3	UCLEZ0009QSZ2		AQ	EQ		A	Cleaning blade		クリーニングプレート
4	PMLT-0150QSZZ		BF	GN		C	Toner shield cushion		トナーシールドモルト
5	PSEL-0130QSZZ		AF	DS		C	Moquette R		モケット R
6	PSEL-0129QSZZ		AF	DS		C	Moquette F		モケット F
9	NCPL-0003QSZ1		AC	DJ		C	Screw coupling		スクリューカップリング
12	LHLDZ0134QSZZ		AC	DJ		A	Pawl holder		爪ホルダー
15	PTME-0046QSZZ		AF	DS		A	Separator pawl		剥離爪
16	PRNGF0106FCZ2		AC	DJ		A	Star ring N2(N2)		スターリング N2
17	LX-RZ0001QSZZ		AB	DD		A	Star ring		スターリング
18	NBRGP0299FCPZ		AD	DJ		C	CL bearing		CL 軸受
19	NSFTZ0020QSZZ		AL	EB		C	Transport screw		搬送スクリュー
20	PMLT-0018QSZ1		AC	DJ		C	Transport screw cushion		搬送スクリューモルト
21	PCAPH0021QSZZ		AC	DJ		C	Toner pipe cap		トナーパイプキャップ
22	NSFTZ0019QSZ1		AE	DS		C	Transport pipe screw		搬送パイプスクリュー
23	PSPAZ0696FCZ2		AC	DJ		C	P cap spacer		P キャップ Spacer
24	PPiPP0016QSZZ		AF	DS		C	Toner pipe		トナーパイプ
25	NGERH0039QSZZ		AE	DS		C	Transport pipe gear(14T)		搬送パイプギヤ
26	MSPRC0045QSZ1		AC	DJ		C	Toner pipe spring		トナーパイプスプリング
27	PSHT-0014QSZZ		AC	DJ		C	Toner pipe shutter		トナーパイプシャッター
28	NGERH0036QSZZ		AC	DJ		C	Transport screw gear(30T)		搬送スクリューギヤ
29	NGERH0038QSZZ		AC	DJ		C	Transport pipe gear(15T)		搬送パイプギヤ
30	NGERH0037QSZZ		AC	DJ		C	Idle gear(26T)		アイドルギヤ
31	LFiX-0007QSZ1		AE	DJ		A	Drum fixing plate B		ドラム固定板 B
32	PCOVP0118QSZZ		AF	DS		D	Drum cover		ドラムカバー
35	PSHEP0135QSZZ		AC	DJ		A	MC guide sheet R		MC ガイドシート R
36	PSHEZ0501QSZZ		AD	DJ		C	Drum MG sheet A		ドラム MG シート A
37	PSHEZ0502QSZZ		AD	DJ		C	Drum MG sheet B		ドラム MG シート B
38	PSHEZ0513QSZ1		AK	EB		C	Paper dust stirring sheet		紙粉攪拌シート
39	PTPE-0026QSZ1		AA	DJ		C	Screw tape		スクリューテープ
40	LHLDZ0035QSZZ		AH	DX		C	MC holder		MC ホルダー
41	QTANP0004QSZZ		AD	DJ		C	Saw blade terminal		ノコギリ端子
42	QTANP0007QSZZ		AC	DJ		C	Grid terminal		グリッド端子
43	PTPE-0005QSZZ		AG	DJ		C	Saw blade tape(Refer to Matrix)		ノコギリテープ
	PTPE-0005QSZZ		AG	DX		C	Saw blade tape(Refer to Matrix)		ノコギリテープ
44	LPLTM0386QSZZ		AG	DX		C	Saw blade		ノコギリ
45	XEBS726P06000		AD	DJ		C	Screw(2.6×6)		ビス
46	XEBS726P05000		AA	DD		C	Screw(2.6×5)		ビス
47	LPLTM0062QSZ1		AG	DS		A	Grid		グリッド
48	LHLDZ0036QSZ1		AD	DJ		C	Grid tension holder		グリッドテンションホルダー
49	PCASZ0016QSZZ		AK	DX		A	MC case		MC ケース
501	CFRM-0021RS74		BE	GN		E	Process frame unit(Refer to Matrix)		プロセスフレームユニット
	CFRM-0021US74	1	BH	HC	N	E	Process frame unit(Refer to Matrix)		プロセスフレームユニット
502	CHLDZ0035RS59		AV	FG		E	MC holder unit(Refer to Matrix)		MC ホルダーユニット
	CHLDZ0035US59	1	AY	FQ	N	E	MC holder unit(Refer to Matrix)		MC ホルダーユニット
503	CTME-0046US51		AN	EG	N	E	Separator pawl unit(Refer to Matrix)		剥離爪ユニット

9 フォトリソユニット (Process unit)

Matrix

No.43-1/2		ノコギリテープ (Saw blade tape)																									
PARTS CODE	Germany, Switzerland, France, Spain, Italy	AR-5623N				AR-5620N				AR-5618N				AR-5620S AR-5618S													
		India, Singapore, Malaysia, Vietnam				Australia, New Zealand				Other				Germany, Switzerland, France, Spain, Italy				India, Malaysia, Vietnam				Australia, New Zealand				Other	
PTPE-0005QSZ2	1st lot	1st lot	1st lot	1st lot	1st lot	1st lot	1st lot	1st lot	1st lot	1st lot	1st lot	1st lot	1st lot	1st lot	1st lot	1st lot	1st lot	1st lot	1st lot	1st lot	1st lot	1st lot	1st lot	1st lot	1st lot		
PTPE-0005QSZZ					1st lot																				1st lot		

No.43-2/2		ノコギリテープ (Saw blade tape)																							
PARTS CODE	AR-5623	AR-5620	AR-5618	AR-5623D	AR-5620D	AR-5618D	AR-5623DA	AR-5620SL																	
	ALL	ALL	ALL	Argentina	ALL																				
PTPE-0005QSZZ	1st lot	1st lot	1st lot	1st lot	1st lot																				

No.501-1/2		フォトリソフレームユニット (Process frame unit)																									
PARTS CODE	Germany, Switzerland, France, Spain, Italy	AR-5623N				AR-5620N				AR-5618N				AR-5620S AR-5618S													
		India, Singapore, Malaysia, Vietnam				Australia, New Zealand				Other				Germany, Switzerland, France, Spain, Italy				India, Malaysia, Vietnam				Australia, New Zealand				Other	
CFRM-0021RS74	1st lot	1st lot	1st lot	1st lot	1st lot	1st lot	1st lot	1st lot	1st lot	1st lot	1st lot	1st lot	1st lot	1st lot	1st lot	1st lot	1st lot	1st lot	1st lot	1st lot	1st lot	1st lot	1st lot	1st lot	1st lot		
CFRM-0021US74	Apr/11	Apr/11	Apr/11	Apr/11	1st lot	Apr/11	Apr/11	Apr/11	Apr/11	1st lot	Apr/11	Apr/11	Apr/11	1st lot	Apr/11	Apr/11	Apr/11	Apr/11	Apr/11	Apr/11	Apr/11	Apr/11	Apr/11	Apr/11	1st lot		

No.501-2/2		フォトリソフレームユニット (Process frame unit)																							
PARTS CODE	AR-5623	AR-5620	AR-5618	AR-5623D	AR-5620D	AR-5618D	AR-5623DA	AR-5620SL																	
	ALL	ALL	ALL	Argentina	ALL																				
CFRM-0021US74	1st lot	1st lot	1st lot	1st lot	1st lot																				

9 7° 042110 (Process unit)

Matrix

No.502-1/2		MC 104° -110 (MC holder unit)													
PARTS CODE	AR-5623N				AR-5620N				AR-5618N			AR-5620S AR-5618S			
	Germany, Switzerland, France, Spain, Italy	India, Singapore, Malaysia, Vietnam	Australia, New Zealand	Other	Germany, Switzerland, France, Spain, Italy	India, Malaysia, Vietnam	Australia, New Zealand	Other	Germany, Switzerland, France, Spain, Italy	India, Singapore, Malaysia, Vietnam	Other	Germany, Switzerland, France	India	Lebanon, Nigeria, Algeria, Egypt, Jordan, Tunisia, Morocco	Other
CHLDZ0035RS59	1st lot	1st lot	1st lot		1st lot	1st lot	1st lot		1st lot	1st lot		1st lot	1st lot	1st lot	
CHLDZ0035US59	Apr/11	Apr/11	Apr/11	1st lot	Apr/11	Apr/11	Apr/11	1st lot	Apr/11	Apr/11	1st lot	Apr/11	Apr/11	Apr/11	1st lot

No.502-2/2		MC 104° -110 (MC holder unit)												
PARTS CODE	AR-5623 AR-5620 AR-5618	AR-5623D AR-5620D AR-5618D	AR-5623DA	AR-5620SL										
	ALL	ALL	Argentina	ALL										
CHLDZ0035US59	1st lot	1st lot	1st lot	1st lot										

No.503-1/2		104° 110 (Separator pawl unit)												
PARTS CODE	AR-5623N				AR-5620N				AR-5618N			AR-5620S AR-5618S		
	Germany, Switzerland, France, Spain, Italy	India, Singapore, Malaysia, Vietnam	Australia, New Zealand	Other	Germany, Switzerland, France, Spain, Italy	India, Malaysia, Vietnam	Australia, New Zealand	Other	Germany, Switzerland, France, Spain, Italy	India, Singapore, Malaysia, Vietnam	Other	Germany, Switzerland, France	India	Lebanon, Nigeria, Algeria, Egypt, Jordan, Tunisia, Morocco
CTME-0046US51				1st lot				1st lot			1st lot			1st lot

No.503-2/2		104° 110 (Separator pawl unit)												
PARTS CODE	AR-5623 AR-5620 AR-5618	AR-5623D AR-5620D AR-5618D	AR-5623DA	AR-5620SL										
	ALL	ALL	Argentina	ALL										
CTME-0046US51	1st lot	1st lot	1st lot	1st lot										

9 フォーメット (Process unit)

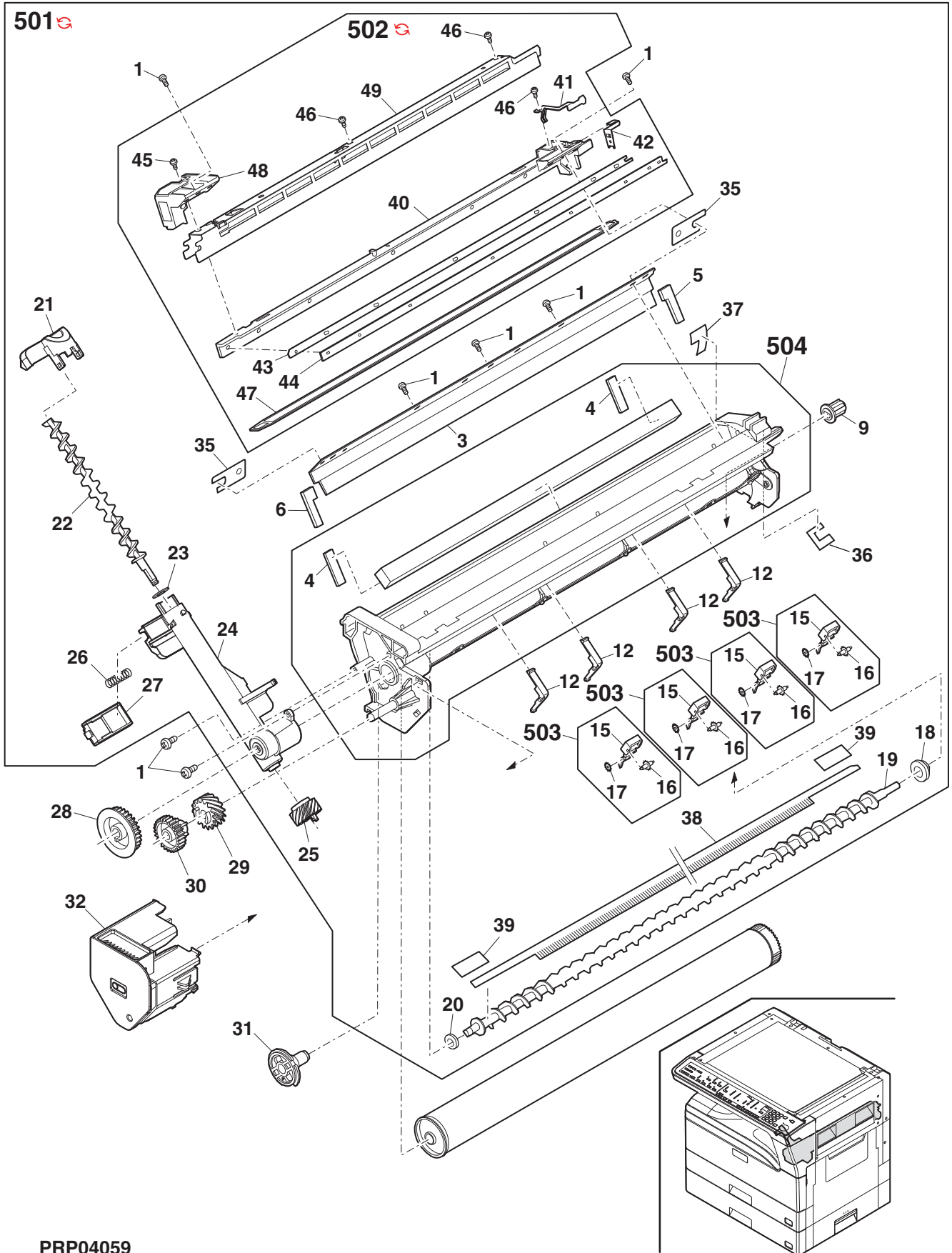

PRP04059

10 現像ユニット (DV unit)

Matrix

No.40-1/2		フィルターホルダーユニット (Filter holder unit)													
PARTS CODE	AR-5623N				AR-5620N				AR-5618N			AR-5620S AR-5618S			
	Germany, Switzerland, France, Spain, Italy	India, Singapore, Malaysia, Vietnam	Australia, New Zealand	Other	Germany, Switzerland, France, Spain, Italy	India, Malaysia, Vietnam	Australia, New Zealand	Other	Germany, Switzerland, France, Spain, Italy	India, Singapore, Malaysia, Vietnam	Other	Germany, Switzerland, France	India	Lebanon, Nigeria, Algeria, Egypt, Jordan, Tunisia, Morocco	Other
CHLDZ0130RS51	1st lot	1st lot	1st lot		1st lot	1st lot	1st lot		1st lot	1st lot		1st lot	1st lot	1st lot	
CHLDZ0130US51				1st lot				1st lot			1st lot				1st lot

No.40-2/2		フィルターホルダーユニット (Filter holder unit)												
PARTS CODE	AR-5623 AR-5620 AR-5618	AR-5623D AR-5620D AR-5618D	AR-5623DA	AR-5620SL										
	ALL	ALL	Argentina	ALL										
CHLDZ0130US51	1st lot	1st lot	1st lot	1st lot										

No.501-1/2		DVボックスユニット (DV box unit)													
PARTS CODE	AR-5623N				AR-5620N				AR-5618N			AR-5620S AR-5618S			
	Germany, Switzerland, France, Spain, Italy	India, Singapore, Malaysia, Vietnam	Australia, New Zealand	Other	Germany, Switzerland, France, Spain, Italy	India, Malaysia, Vietnam	Australia, New Zealand	Other	Germany, Switzerland, France, Spain, Italy	India, Singapore, Malaysia, Vietnam	Other	Germany, Switzerland, France	India	Lebanon, Nigeria, Algeria, Egypt, Jordan, Tunisia, Morocco	Other
DUNT-0950RSZZ	1st lot	1st lot	1st lot		1st lot	1st lot	1st lot		1st lot	1st lot		1st lot	1st lot	1st lot	
 DUNT-0950USZZ	Apr/11	Apr/11	Apr/11	1st lot	Apr/11	Apr/11	Apr/11	1st lot	Apr/11	Apr/11	1st lot	Apr/11	Apr/11	Apr/11	1st lot

No.501-2/2		DVボックスユニット (DV box unit)												
PARTS CODE	AR-5623 AR-5620 AR-5618	AR-5623D AR-5620D AR-5618D	AR-5623DA	AR-5620SL										
	ALL	ALL	Argentina	ALL										
 DUNT-0950USZZ	1st lot	1st lot	1st lot	1st lot										

10 現像ユニット (DV unit)

Matrix

No.502-1/2		TN カットユニット (TN guide unit)													
PARTS CODE	Germany, Switzerland, France, Spain, Italy	AR-5623N			AR-5620N			AR-5618N			AR-5620S AR-5618S				
		India, Singapore, Malaysia, Vietnam	Australia, New Zealand	Other	Germany, Switzerland, France, Spain, Italy	India, Malaysia, Vietnam	Australia, New Zealand	Other	Germany, Switzerland, France, Spain, Italy	India, Singapore, Malaysia, Vietnam	Other	Germany, Switzerland, France	India	Lebanon, Nigeria, Algeria, Egypt, Jordan, Tunisia, Morocco	Other
CG i DM0 1 5 4 RS 5 1	1st lot	1st lot	1st lot		1st lot	1st lot	1st lot		1st lot	1st lot		1st lot	1st lot	1st lot	
CG i DM0 1 5 4 US 5 1				1st lot				1st lot				1st lot			1st lot

No.502-2/2		TN カットユニット (TN guide unit)													
PARTS CODE	AR-5623	AR-5620	AR-5618	AR-5623D	AR-5620D	AR-5618D	AR-5623DA	AR-5620SL							
	ALL			ALL			Argentina	ALL							
CG i DM0 1 5 4 US 5 1	1st lot	1st lot	1st lot	1st lot	1st lot										

10 現像ユニット (DV unit)

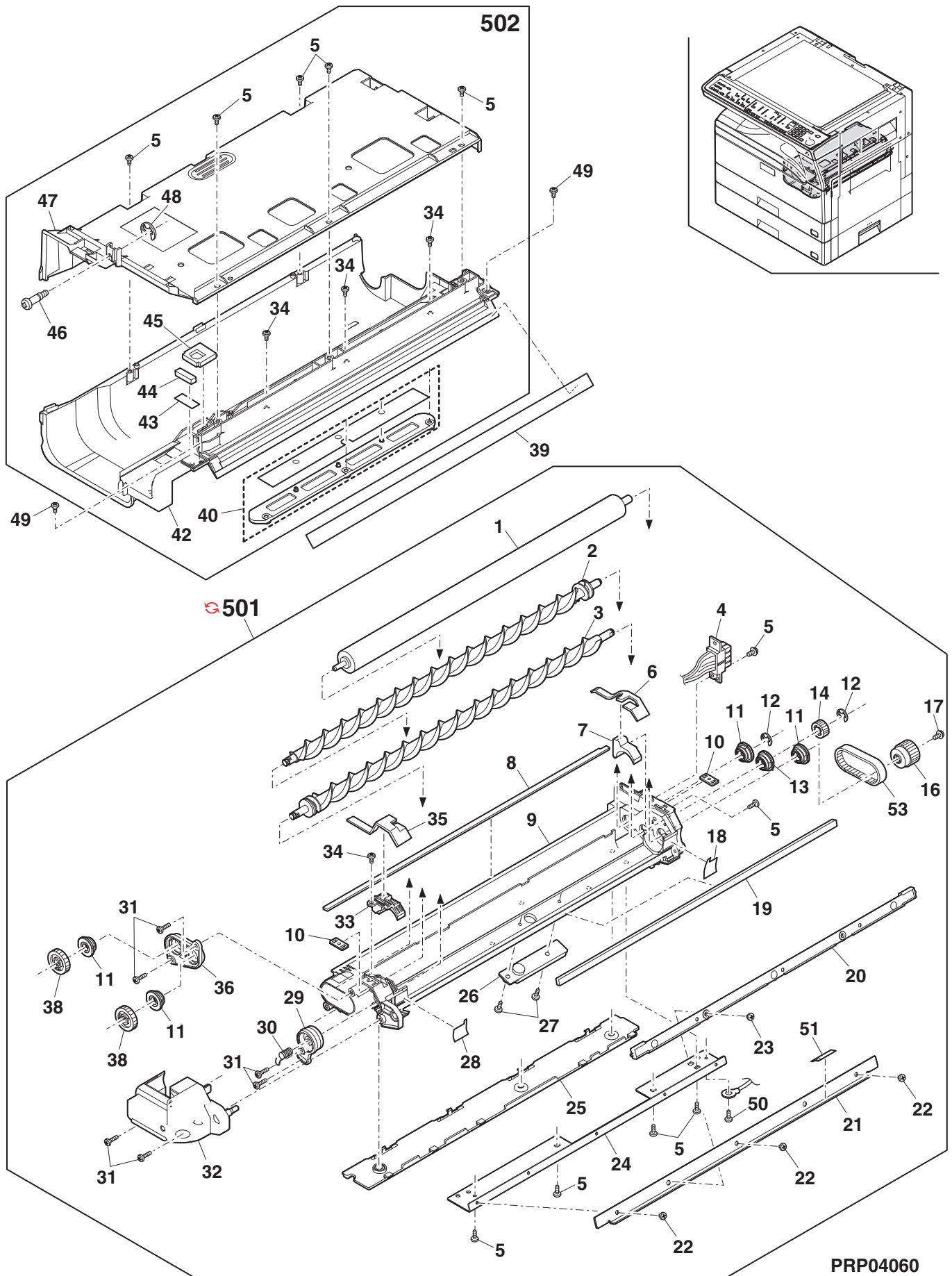

PRP04060

11 定着ユニット (Fusing unit)

NO.	PARTS CODE	Inter-change	PRICE RANK		NEW MARK	PART RANK	DESCRIPTION	TR No.	Effective time
			Ex.	Ja.					
1	PCOVP0119QSZZ		AD	DJ		C	Thermostat cover	サーモスタットカバー	
2	XEBS730P08000		AC	DD		C	Screw(3×8)	ビス	
3	RTHM-0007QSZZ		AL	EB		B	Thermostat	サーモスタット	
4	LX-BZ1181FCZZ		AB	DD		C	Screw	ビス	
5	PCOVP0164QSZZ		BA	FX		D	Fusing cover	定着カバー	
6	RLMPU0038QSPZ		AY	FQ		B	Heater lamp(Refer to Matrix)	ヒーターランプ	
	RLMPU0037QSPZ		AY	FQ		B	Heater lamp(Refer to Matrix)	ヒーターランプ	
7	LSTPP0116FCZZ		AA	DD		C	Roller stopper A2	ローラストッパ - A2	
8	NBRGP0567FCZZ		AG	DX		A	Fusing bearing	定着軸受	
10	CFRM-0017QS04		AH	DX		D	Fusing frame F	定着フレーム F	
11	NROLi0187QSZZ		BA	FX		C	Upper heat roller	[AB series] 上ヒートローラー	
12	CFRM-0018QS04		AH	DX		D	Fusing frame R	定着フレーム R	
13	NGERH0221QSZZ		AF	DS		C	Fusing gear J3	定着ギヤ J3	
14	LHLDZ0127QSZZ		AE	DJ		C	Lamp holder	ランプホルダー	
15	XBPS730P10KSO		AB	DD		C	Screw(3×10KS)	ビス	
16	XHBS730P06000		AC	DD		C	Screw(3×6)	ビス	
17	LPLTM0050QSZZ		AP	EQ		C	Fusing joint plate	定着連結板	
18	MSPRT0086QSZZ		AB	DJ		C	Upper pawl pressure spring	上爪加圧スプリング	
19	RDTCT0026QSZZ		AV	FG		A	Thermistor	サーミスター	
20	PGiDM0201QSZZ		AN	EG		C	Fusing rear paper guide	定着後カバーガイド	
21	XEBS730P06000		AA	DD		C	Screw(3×6)	ビス	
22	XBBS730P06000		AC	DD		C	Screw(3×6)	ビス	
23	LPLTP0051QSZZ		AD	DJ		C	PG fixing plate	PG 固定板	
24	XBBS740P08000		AA	DD		C	Screw(4×8)	ビス	
25	PGiDH0155QSZZ		AP	EQ		C	Fusing front paper guide	定着前カバーガイド	
26	LX-BZ0026GCZ1		AC	DD		C	Screw	ビス	
27	NROLR0186QSZZ		BE	GN		C	Pressure roller	加圧ローラー	
28	NBRGP0035QSZZ		AD	DJ		C	Pressure bearing	圧着軸受	
29	XRESP30-06000		AA	DD		C	E type ring(E3)	E リング	
30	LX-BZ0013QSP1		AD	DD		C	Screw(3×7)	ビス	
32	MSPRC0470QSZZ		AD	DJ		C	Fusing pressure spring	定着加圧スプリング	
33	MLEVP0121QSZZ		AC	DJ		C	Fusing pressure lever F	定着加圧レバー F	
34	MLEVP0019QSZZ		AE	DJ		C	Release lever F	圧解レバー F	
35	MLEVP0020QSZZ		AE	DJ		C	Release lever R	圧解レバー R	
36	MLEVP0122QSZZ		AC	DJ		C	Fusing pressure lever R	定着加圧レバー R	
37	PTME-0039QSZZ		AE	DS		A	Upper separator pawl	上剥離爪	
38	PGiDM0103QSZZ		AD	DJ		C	Fusing front guide R	[200V series] 定着前ガイド R	
39	TLABH0062QSZZ		AE	DJ		D	High temperature caution label	高温注意ラベル	
40	LFRM-0084QSZZ		AN	EG		D	Fusing lower frame	定着下フレーム	
41	LPLTP0589QSZZ		AP	EQ		C	Reverse gate	反転ゲート	
42	MLEVP0026QSZZ		AE	DS		C	DMC actuator(Refer to Matrix)	DMC アクチュエーター	
	MLEVP0026QSZZ		AE	DS		C	DMC actuator(Refer to Matrix)	DMC アクチュエーター	
43	MSPRD0399QSZZ		AC	DJ		C	Rotation spring	回転スプリング	
44	MSPRD0118QSZZ		AB	DJ		C	Actuator return spring	アクチュエーター復帰スプリング	
45	XHBS730P08000		AB	DD		C	Screw(3×8)	ビス	
46	PSHEZ0105QSZZ		AC	DJ		C	Fusing suede	定着スエード	
47	LX-BZ0098QSZZ		AC	DD		C	Fusing fixing screw(3×12)	定着取付用ビス	
50	XBPS730P06KSO		AB	DD		C	Screw(3×6KS)	ビス	
51	PTME-0044QSZZ		AQ	EQ		C	Lower separator pawl	下剥離爪	
52	MSPRD0398QSZZ		AC	DJ		C	Separator pawl spring R	剥離爪スプリング R	
53	MSPRD0397QSZZ		AC	DJ		C	Separator pawl spring F	剥離爪スプリング F	
54	PGiDM0102QSZZ		AD	DJ		C	Fusing front guide F	[200V series] 定着前ガイド F	
57	TLABH0364QSZZ		AA	DJ		D	Green label	グリーンラベル	
58	NBRGY0022QSZZ		AL	EB		A	FU pressure bearing	FU 加圧軸受	
59	CPLTM0255QS03		AS	EQ		B	Felt fixing plate	フェルト取付板	
60	TLABH0685QSZZ		AD	DJ		D	High temperature caution label	高温注意ラベル	
61	LHLDZ0163QSZZ		AD	DJ		C	Fusing F holder	定着 F ホルダー	
62	DUNTK0803RSZZ		AH	DX		C	Resistor(500MΩ)(Refer to Matrix)	抵抗	
	DUNTK0803USZZ		AL	EB		C	Resistor(500MΩ)(Refer to Matrix)	抵抗	
63	LX-WZ0001QSZZ		AC	DD		C	Separator pawl washer	剥離爪ワッシャー	
64	MSPRD0425QSZZ		AC	DJ		C	High resistor earth spring(Refer to Matrix)	ハイレジスタースプリング	
65	QEARP0009QSZZ		AD	DJ		B	High resistor electrode plate	ハイレジスタ電極板	
66	PCLR-0018QSZZ		AG	DX		C	Delivery guide collar	排紙ガイドコリヤ	
67	PSPAZ0060QSZZ		AD	DJ	N	C	Insulate spacer	絶縁スペーサー	1st lot
501	CPLTP0589RS51		AR	EQ		E	Reverse gate unit	反転ゲートユニット	
	CPLTP0589US51	1	AV	FG	N	E	Reverse gate unit	反転ゲートユニット	11/04
	(Unit)								
901	DUNTW0961RS12		BT	MW		E	Fusing unit(Refer to Matrix)	定着ユニット	
	DUNTW0961US12	1	BT	NE	N	E	Fusing unit(Refer to Matrix)	定着ユニット	

11 定着ユニット (Fusing unit)

Matrix

No.6	ヒーターランプ (Heater lamp)												
PARTS CODE	200V series												
	120V												
RLMPU0038QSPZ	1st lot												
RLMPU0037QSPZ		1st lot											

No.42-1/2	DMC アクチュエーター (DMC actuator)														
PARTS CODE	AR-5623N				AR-5620N				AR-5618N			AR-5620S AR-5618S			
	Germany, Switzerland, France, Spain, Italy	India, Singapore, Malaysia, Vietnam	Australia, New Zealand	Other	Germany, Switzerland, France, Spain, Italy	India, Malaysia, Vietnam	Australia, New Zealand	Other	Germany, Switzerland, France, Spain, Italy	India, Singapore, Malaysia, Vietnam	Other	Germany, Switzerland, France	India	Lebanon, Nigeria, Algeria, Egypt, Jordan, Tunisia, Morocco	Other
MLEVP0026QSZ3	1st lot	1st lot	1st lot		1st lot	1st lot	1st lot	1st lot	1st lot	1st lot		1st lot	1st lot	1st lot	
MLEVP0026QSZ4				1st lot				1st lot			1st lot				1st lot

No.42-2/2	DMC アクチュエーター (DMC actuator)												
PARTS CODE	AR-5623 AR-5620 AR-5618	AR-5623D AR-5620D AR-5618D	AR-5623DA	AR-5620SL									
	ALL	ALL	Argentina	ALL									
MLEVP0026QSZ4	1st lot	1st lot	1st lot	1st lot									

No.62-1/2	抵抗 (Resistor)														
PARTS CODE	AR-5623N				AR-5620N				AR-5618N			AR-5620S AR-5618S			
	Germany, Switzerland, France, Spain, Italy	India, Singapore, Malaysia, Vietnam	Australia, New Zealand	Other	Germany, Switzerland, France, Spain, Italy	India, Malaysia, Vietnam	Australia, New Zealand	Other	Germany, Switzerland, France, Spain, Italy	India, Singapore, Malaysia, Vietnam	Other	Germany, Switzerland, France	India	Lebanon, Nigeria, Algeria, Egypt, Jordan, Tunisia, Morocco	Other
DUNTK0803RSZZ	1st lot	1st lot	1st lot		1st lot	1st lot	1st lot	1st lot	1st lot	1st lot	1st lot	1st lot	1st lot	1st lot	
DUNTK0803USZZ				1st lot				1st lot			1st lot				1st lot

11 定着ユニット (Fusing unit)

Matrix

No.62-2/2		抵抗 (Resistor)												
PARTS CODE	AR-5623 AR-5620 AR-5618	ALL	AR-5623D AR-5620D AR-5618D	Argentina AR-5623DA	AR-5620SL									
DUNTK0803USZZ	1st lot	1st lot	1st lot	1st lot										

No.64-1/2		ハイレジター・スプリング (High resistor earth spring)															
PARTS CODE	Germany, Switzerland, France, Spain, Italy	India, Singapore, Malaysia, Vietnam	Australia, New Zealand	Other	Germany, Switzerland, France, Spain, Italy	India, Malaysia, Vietnam	Australia, New Zealand	Other	Germany, Switzerland, France, Spain, Italy	India, Singapore, Malaysia, Vietnam	Other	Germany, Switzerland, France	India	AR-5623N	AR-5620N	AR-5618N	AR-5620S AR-5618S
MSPRD0425QSZZ	1st lot	1st lot	1st lot		1st lot	1st lot	1st lot		1st lot	1st lot		1st lot	1st lot	1st lot			

No.64-2/2		ハイレジター・スプリング (High resistor earth spring)															
PARTS CODE	AR-5623 AR-5620 AR-5618	ALL	AR-5623D AR-5620D AR-5618D	Argentina AR-5623DA	AR-5620SL												

No.901-1/2		定着ユニット (Fusing unit)															
PARTS CODE	AR-5623N AR-5620N AR-5618N	200V series	AR-5623D AR-5620D AR-5618D	Argentina AR-5623DA	AR-5620SL												
DUNTW0961RS12	1st lot	1st lot															
DUNTW0961US12	Apr/11	Apr/11	1st lot	1st lot				1st lot	1st lot	1st lot							

11 定着ユニット (Fusing unit)

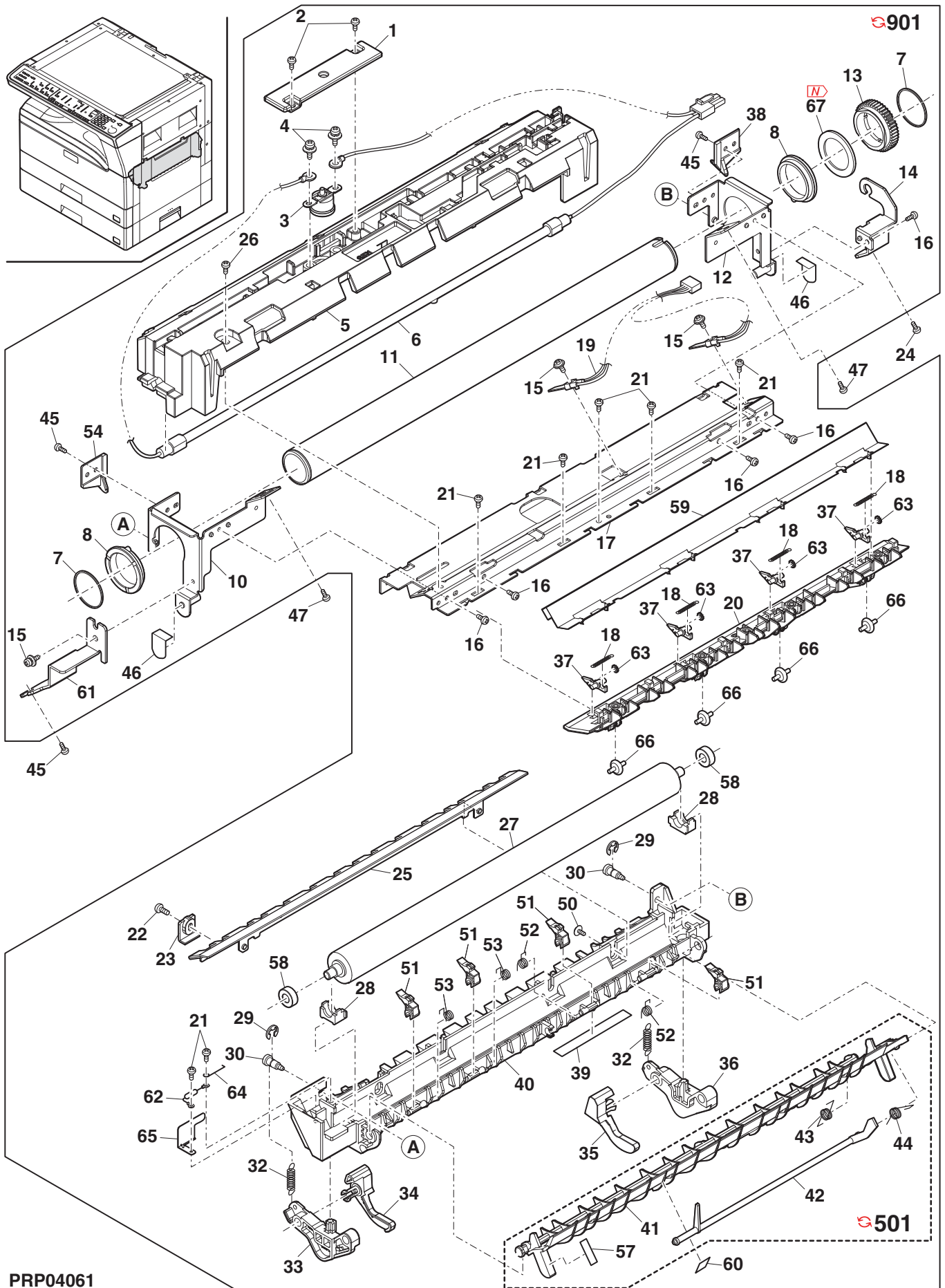

PRP04061

12 メイン駆動ユニット (Main driving unit)

NO.	PARTS CODE	Inter-change	PRICE RANK		NEW MARK	PART RANK	DESCRIPTION	TR No.	Effective time
			Ex.	Ja.					
1	PGiDM0190QSZZ		AH	DX		C	Harness guide		ハ-ネスカ'イト'
2	XHBS730P04000		AA	DD		C	Screw(3x4)		ビス
4	DHAi-0557QSPZ		AF	DS		C	HND SOL harness		HND SOL ハ-ネス
5	DHAi-0514QSP1		AX	FG		C	Main motor harness(Refer to Matrix)		メインモーターハ-ネス
	DHAi-0514QSPZ		AG	DX		C	Main motor harness(Refer to Matrix)		メインモーターハ-ネス
	DHAi-0631QSPZ		BH	HC		C	Main motor harness(Refer to Matrix)		メインモーターハ-ネス
6	XBBS740P08000		AA	DD		C	Screw(4x8)		ビス
7	RMOTP0061QSPZ		BS	MW		B	Main motor(Refer to Matrix)		メインモーター
7	RMOTP0073QSPZ	-	BW	RR		B	Main motor(Refer to Matrix)	[Missing parts code]	メインモーター
8	PCLC-0033QSZ1		AR	EQ		B	PS clutch		PS クラッチ
9	LPLTM0252QSZZ		AD	DJ		C	PS earth plate		PS ア-ス板
10	NGERH0054QSZZ		AD	DJ		C	Gear(33/20T)		ギヤ
11	LX-WZ0314FCZ1		AA	DD		C	Poly slider		ポリスライダ-
12	XRESP40-06000		AA	DD		C	E type ring(E4)		E リング
13	NGERH0056QSZZ		AE	DJ		C	Ratchet gear(33T)		ラチェットギヤ
14	NGERH0055QSZZ		AE	DJ		C	Ratchet gear(44T)		ラチェットギヤ
15	MSPRC0477QSZZ	-	AC	DD		C	HT ratchet spring	[Missing parts code]	HT ラチェットスプリング
16	NGERH0016QSZ1		AD	DJ		C	Coupling gear(34T)		カップリングギヤ
17	NGERH0013QSZZ		AG	DX		C	Gear(31/17T)		ギヤ
18	CPLTM0537US05		BN	LE		B	DUP main drive plate(Refer to Matrix)		DUP メイン駆動板
	CPLTM0537US06		BN	HZ		B	DUP main drive plate(Refer to Matrix)		DUP メイン駆動板
19	NGERH0010QSZZ		AD	DJ		C	Gear(28T)		ギヤ
20	NGERH0009QSZZ		AD	DJ		C	Gear(46/16T)		ギヤ
21	NGERH0014QSZZ		AD	DJ		C	Gear(30/15T)		ギヤ
22	NGERH0011QSZ1		AC	DJ		C	MG gear		MG ギヤ
23	MSPRC2132FCZ2		AA	DJ		C	MG roller spring		MG ローラースプリング
24	NCPL-0004FCZZ		AB	DD		C	Coupling B		カップリング B
25	NGERH0052QSZZ		AE	DJ		C	Gear(38/18T)		ギヤ
26	NGERH0007QSZZ		AH	DX		C	Gear(68/26T)		ギヤ
27	NGERH0057QSZZ		AE	DJ		C	Gear(41T)		ギヤ
28	CGERH0274US53		AT	EZ		E	Gear unit(55T)(Refer to Matrix)		ギヤユニット
29	NGERH0275QSZZ		AC	DD		C	Gear(23/27T)		ギヤ
30	NGERH0012QSZZ		AE	DS		C	Gear(20T)		ギヤ
31	NGERH0058QSZZ		AF	DS		C	Gear(21/17T)		ギヤ
32	XHBS730P08000		AB	DD		C	Screw(3x8)		ビス
36	NGERH0053QSZZ		AD	DJ		C	Gear(25T/28T)	[AR-5620S/5618S/5623/5620/5618/5620SL]	ギヤ
37	LX-WZ0002QSZ1		AB	DD		C	PO belt washer	[AR-5620S/5618S/5623/5620/5618/5620SL]	PO ベルトワッシャー
38	XRESP40-06000		AA	DD		C	E type ring(E4)	[AR-5620S/5618S/5623/5620/5618/5620SL]	E リング
501	CGERH0011RS51		AE	DS		E	MG gear unit(Refer to Matrix)		MG ギヤユニット
	CGERH0011US51		AE	DJ		E	MG gear unit(Refer to Matrix)		MG ギヤユニット
502	CPLTM0537RS74		BB	GD		E	Drive sub unit(SIMP)(Refer to Matrix)		駆動サブユニット
	CPLTM0537US74	1	BG	GX	N	E	Drive sub unit(SIMP)(Refer to Matrix)		駆動サブユニット
	CPLTM0537RS75		BL	HL		E	Drive sub unit(DUP)(Refer to Matrix)		駆動サブユニット
	CPLTM0537US75	1	BG	GT	N	E	Drive sub unit(DUP)(Refer to Matrix)		駆動サブユニット

12 メイン駆動ユニット (Main driving unit)

Matrix

No.5		メインモーターハネス (Main motor harness)															
PARTS CODE	AR-5623N	AR-5620N			AR-5618N			AR-5620S	AR-5618S	AR-5623	AR-5620	AR-5618	AR-5623D	AR-5623DA	AR-5620D	AR-5618D	AR-5620SL
	ALL	India, Malaysia, Vietnam	Australia, New Zealand, Germany, Switzerland, France, Spain, Italy		Other	Germany, Switzerland, France, Spain, Italy	India, Singapore, Malaysia, Vietnam	Other	ALL	ALL	ALL	ALL	ALL	ALL	ALL	ALL	ALL
DHA i - 0514QSP1	1st lot		1st lot		1st lot	1st lot											
DHA i - 0514QSPZ				1st lot			1st lot	1st lot			1st lot				1st lot	1st lot	
DHA i - 0631QSPZ	1st lot									1st lot			1st lot				

No.7		メインモーター (Main motor)															
PARTS CODE	AR-5623N	AR-5620N	AR-5618N	AR-5620S	AR-5618S	AR-5623	AR-5620	AR-5618	AR-5623D	AR-5620D	AR-5618D	AR-5623DA	AR-5620SL				
	ALL	ALL	ALL	ALL	ALL	ALL	ALL	ALL	ALL	ALL	ALL	Argentina	ALL				
RMOTP0061QSPZ	1st lot	1st lot	1st lot	1st lot	1st lot	1st lot	1st lot	1st lot	1st lot	1st lot	1st lot	1st lot	1st lot				
RMOTP0073QSPZ	1st lot			1st lot		1st lot		1st lot		1st lot		1st lot					

No.18		DUP メイン駆動板 (DUP main drive plate)															
PARTS CODE	AR-5623N	AR-5620N	AR-5618N	AR-5620S	AR-5618S	AR-5623	AR-5620	AR-5618	AR-5623D	AR-5620D	AR-5618D	AR-5623DA	AR-5620SL				
	ALL	ALL	ALL	ALL	ALL	ALL	ALL	ALL	ALL	ALL	ALL	Argentina	ALL				
CPLTM0537US05	1st lot	1st lot	1st lot	1st lot	1st lot	1st lot	1st lot	1st lot	1st lot	1st lot	1st lot	1st lot	1st lot				
CPLTM0537US06	1st lot						1st lot	1st lot									

No.28-1/2		ギヤユニット (Gear unit)													
PARTS CODE	AR-5623N			AR-5620N			AR-5618N			AR-5620S			AR-5618S		
	Germany, Switzerland, France, Spain, Italy	India, Singapore, Malaysia, Vietnam	Australia, New Zealand	Other	Germany, Switzerland, France, Spain, Italy	India, Malaysia, Vietnam	Australia, New Zealand	Other	Germany, Switzerland, France, Spain, Italy	India, Singapore, Malaysia, Vietnam	Other	Germany, Switzerland, France	India	Lebanon, Nigeria, Algeria, Egypt, Jordan, Tunisia, Morocco	Other
CGERH0274US53			1st lot				1st lot				1st lot			1st lot	

12 メイン駆動ユニット (Main driving unit)

Matrix

No.28-2/2	ギヤユニット (Gear unit)												
PARTS CODE	AR-5623 AR-5620 AR-5618	AR-5623D AR-5620D AR-5618D	AR-5623DA	AR-5620SL									
	ALL	ALL	Argentina	ALL									
CGERH0274US53	1st lot	1st lot	1st lot	1st lot									

No.501-1/2	MGギヤユニット (MG gear unit)														
PARTS CODE	AR-5623N			AR-5620N				AR-5618N			AR-5620S AR-5618S				
	Germany, Switzerland, France, Spain, Italy	India, Singapore, Malaysia, Vietnam	Australia, New Zealand	Other	Germany, Switzerland, France, Spain, Italy	India, Malaysia, Vietnam	Australia, New Zealand	Other	Germany, Switzerland, France, Spain, Italy	India, Singapore, Malaysia, Vietnam	Other	Germany, Switzerland, France	India	Lebanon, Nigeria, Algeria, Egypt, Jordan, Tunisia, Morocco	Other
CGERH0011RS51	1st lot	1st lot	1st lot		1st lot	1st lot	1st lot		1st lot	1st lot		1st lot	1st lot	1st lot	
CGERH0011US51				1st lot				1st lot			1st lot				1st lot

No.501-2/2	MGギヤユニット (MG gear unit)												
PARTS CODE	AR-5623 AR-5620 AR-5618	AR-5623D AR-5620D AR-5618D	AR-5623DA	AR-5620SL									
	ALL	ALL	Argentina	ALL									
CGERH0011US51	1st lot	1st lot	1st lot	1st lot									

12 メイン駆動ユニット (Main driving unit)

Matrix

No.502-1/2		駆動サブユニット (SIMP)(Drive sub unit) 駆動サブユニット (DUP)(Drive sub unit)																
PARTS CODE		AR-5623N					AR-5620N					AR-5618N			AR-5620S AR-5618S			
		Germany, Switzerland, France, Spain, Italy	India, Singapore, Malaysia, Vietnam	Australia, New Zealand	Other		Germany, Switzerland, France, Spain, Italy	India, Malaysia, Vietnam	Australia, New Zealand	Other		Germany, Switzerland, France, Spain, Italy	India, Singapore, Malaysia, Vietnam	Other	Germany, Switzerland, France	India	Lebanon, Nigeria, Algeria, Egypt, Jordan, Tunisia, Morocco	Other
	CPLTM0537RS74														1st lot	1st lot	1st lot	
	CPLTM0537US74														Apr/11	Apr/11	Apr/11	1st lot
	CPLTM0537RS75	1st lot	1st lot	1st lot			1st lot	1st lot	1st lot			1st lot	1st lot					
	CPLTM0537US75	Apr/11	Apr/11	Apr/11	1st lot		Apr/11	Apr/11	Apr/11	1st lot		Apr/11	Apr/11	1st lot				

No.502-2/2		駆動サブユニット (SIMP)(Drive sub unit) 駆動サブユニット (DUP)(Drive sub unit)																
PARTS CODE		AR-5623	AR-5620	AR-5618	AR-5623D	AR-5620D	AR-5618D	AR-5623DA	AR-5620SL									
		ALL	ALL	Argentina	ALL													
	CPLTM0537US74	1st lot							1st lot									
	CPLTM0537US75		1st lot	1st lot														

12 メイン駆動ユニット (Main driving unit)

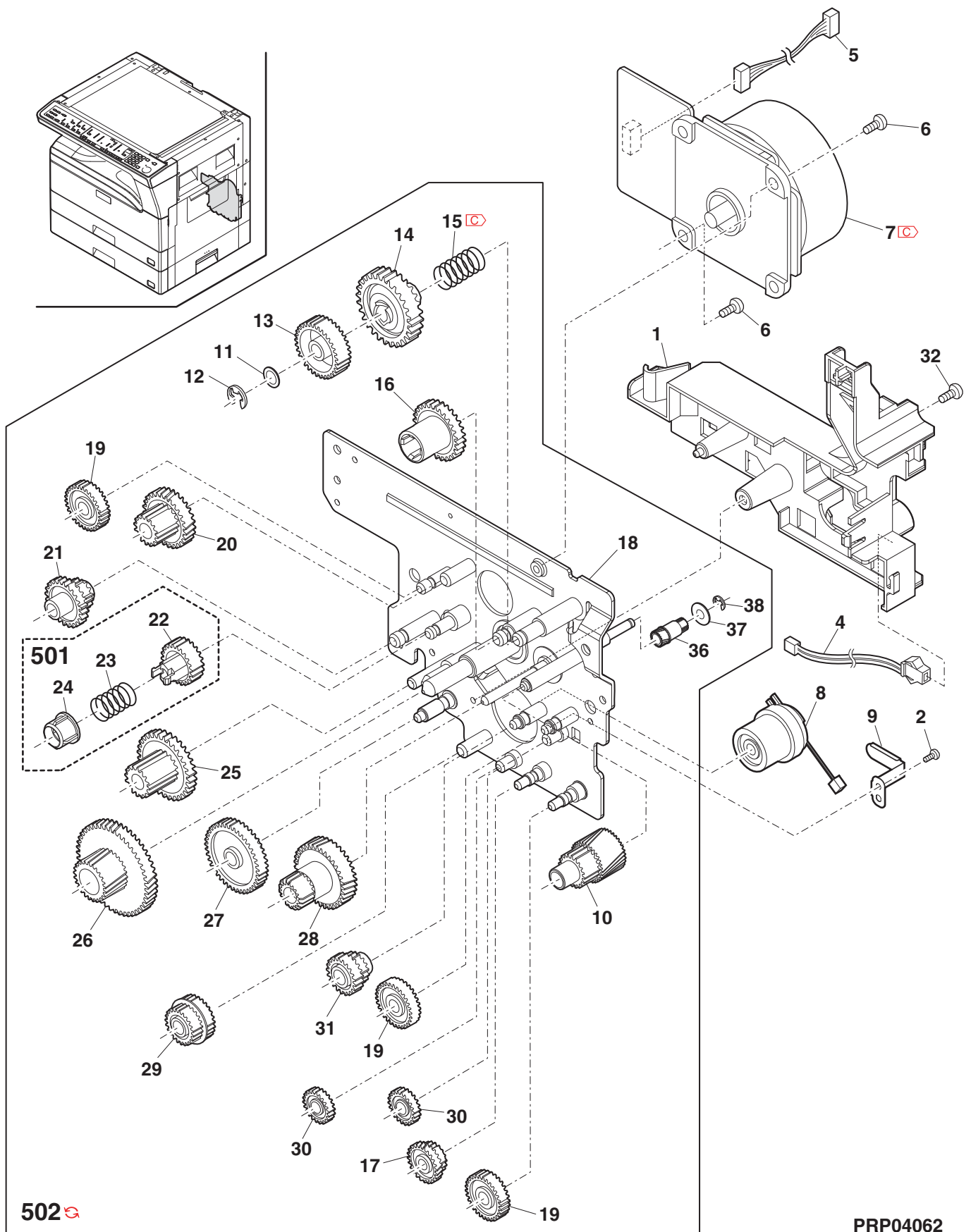

PRP04062

13 台板ユニット1(Base plate unit 1)

NO.	PARTS CODE	Inter-change	PRICE RANK		NEW MARK	PART RANK	DESCRIPTION	TR No.	Effective time
			Ex.	Ja.					
1	QSW-B0017QSZZ		AF	DS		B	Tray detect switch		
2	DHAi-0315QSZZ		AD	DJ		C	Tray detect switch harness		
3	LPLTM0504QSZZ		AC	DJ		C	Joint plate S [AR-5623N/5620N/5623/5620/5623D/5623DA/5620D]		
4	XEBS740P12000		AA	DD		C	Screw(4x12)		
6	LPLTM0065QSZZ		AL	EB		C	Base plate reinforce plate F		
7	XEPS740P12000		AB	DD		C	Screw(4x12)		
8	PSHEZ0671QSZZ		AC	DD		C	Drive plate sheet		
9	LSTPP0358FCZZ		AF	DS		C	Wire fixing stopper		
10	PCLC-0034QSZ1		AR	EQ		B	PF clutch 1		
11	XEBS730P08000		AC	DD		C	Screw(3x8)		
13	DHAi-0295QSZZ		AC	DJ		C	Earth harness		
14	NSFTZ0119QSZZ		AE	DS		C	Sub drive paper feed shaft		
15	XPSSJ30-18000		AB	DD		C	Spring pin		
16	NBRGM0501FCZZ		AB	DJ		C	Bearing		
17	NGERH0254QSZZ		AD	DJ		C	Gear(34-24T)		
18	XRESP50-06000		AA	DD		C	E type ring(E5)		
19	XBBS730P06000		AC	DD		C	Screw(3x6)		
20	XRESP40-05000		AA	DD		C	E type ring(E4)		
21	MSPRD0148QSZZ		AB	DJ		C	Manual paper feed sensor spring		
22	NSFTZ0101QSZZ		AC	DJ		C	Roller shaft		
23	PSHEZ0133QSZZ		AD	DJ		C	Paper feed sheet		
24	CPWBF0147QSE4		AL	EB		E	Manual paper feed sensor PWB(Refer to Matrix)		
	CPWBF0191US53		AL	EB		E	Manual paper feed sensor PWB(Refer to Matrix)		
25	MLEVP0023QSZZ		AE	DS		C	MF sensor actuator		
26	PCOVP0033QSZ2		AF	DJ		D	Manual paper feed sensor cover		
27	LRALP0015USZ1		AK	DX		C	Base plat rail R		
28	PSHEZ0378QSZ1		AG	DX		C	Separation sheet(Refer to Matrix)		
	PSHEZ0378QSZZ		AG	DX		C	Separation sheet(Refer to Matrix)		
29	LPLTP0348QSZZ		AC	DJ		C	Pressure plate		
30	MSPRC0301QSZZ		AD	DJ		C	Pressure plate spring		
31	PFTA-0018QSZ2		AF	DS		D	Pressure plate cover		
32	MLEVP0024QSZZ		AF	DS		C	Sensor lever ACT		
33	LDAiS0029QSZZ		AD	DJ		D	Sensor base		
34	NKOM-0011QSZZ		AC	DJ		C	Manual paper feed collar		
35	MSPRD0233QSZ1		AC	DJ		C	MF actuator spring		
36	MSPRD0340QSZZ		AC	DJ		C	Collar spring		
37	LHLDZ0100QSZ1		AE	DS		C	PS holder		
38	MSPRD0300QSZZ		AD	DJ		C	PS front actuator spring		
39	MLEVP0091QSZ1		AC	DD		C	PS front actuator		
40	LBRC-0012QSZZ		AD	DJ		C	Collar bracket		
41	GLEGG0064FCZZ		AC	DJ		C	Rubber foot(Refer to Matrix)		
42	MLEVP0044QSZZ		AE	DS		C	MF sensor actuator 2		
43	XEBS740P10000		AA	DD		C	Screw(4x10)		
44	NGERH0250QSZZ		AC	DD		C	Gear(28T) [AR-5623N/5620N/5618N/5623/5620/5618/5623D/5620D/5618D/5623DA]		
45	NGERH0251QSZZ		AD	DJ		C	Gear(31-24T) [AR-5623N/5620N/5618N/5623/5620/5618/5623D/5620D/5618D/5623DA]		
46	CPLTM0535US01		AZ	FQ		C	Joint drive plate [AR-5623N/5620N/5618N/5623/5620/5618/5623D/5620D/5618D/5623DA]		
47	NGERH0252QSZZ		AC	DD		C	Gear(20T)		
48	NGERH0253QSZZ		AD	DJ		C	Gear(20-27T) [AR-5623N/5620N/5618N/5623/5620/5618/5623D/5620D/5618D/5623DA]		
49	DHAi-0316QSZZ		AE	DJ		C	CAS EMP harness		
50	DHAi-0318QSZZ		AE	DJ		C	Pin harness		
51	VHPGP1S73P+-18		AF	DS		B	Photo transistor		
52	PCOVP0091QSZZ		AC	DJ		D	PS sensor cover		
55	LPLTM0555USZZ		AG	DS		C	Joint gear reinforce plate [AR-5623N/5620N/5618N/5623/5620/5618/5623D/5620D/5618D/5623DA]		
56	LPLTM0554QSZZ		AC	DD		C	Main drive reinforce plate		
57	XEBS740P14000		AB	DD		C	Screw(4x14) [AR-5623N/5620N/5623/5620/5623D/5623DA/5620D]		
58	LPLTM0587QSZZ	-	AC	DD	N	C	Sub joint plate [AR-5623N/5620N/5618N/5623/5620/5618/5623D/5620D/5618D/5623DA] [Missing parts code]		1st lot

13 台板ユニット1(Base plate unit 1)

Matrix

No.24-1/2		手差しセンサー基板 (Manual paper feed sensor PWB)													
PARTS CODE	AR-5623N				AR-5620N				AR-5618N			AR-5620S AR-5618S			
	Germany, Switzerland, France, Spain, Italy	India, Singapore, Malaysia, Vietnam	Australia, New Zealand	Other	Germany, Switzerland, France, Spain, Italy	India, Malaysia, Vietnam	Australia, New Zealand	Other	Germany, Switzerland, France, Spain, Italy	India, Singapore, Malaysia, Vietnam	Other	Germany, Switzerland, France	India	Lebanon, Nigeria, Algeria, Egypt, Jordan, Tunisia, Morocco	Other
CPWBF0147QSE4	1st lot	1st lot	1st lot		1st lot	1st lot	1st lot		1st lot	1st lot		1st lot	1st lot	1st lot	
CPWBF0191US53				1st lot				1st lot			1st lot				1st lot

No.24-2/2		手差しセンサー基板 (Manual paper feed sensor PWB)											
PARTS CODE	AR-5623 AR-5620 AR-5618	AR-5623D AR-5620D AR-5618D	AR-5623DA	AR-5620SL									
	ALL	ALL	Argentina	ALL									
CPWBF0191US53	1st lot	1st lot	1st lot	1st lot									

No.28-1/2		捌きシート (Separation sheet)													
PARTS CODE	AR-5623N				AR-5620N				AR-5618N			AR-5620S AR-5618S			
	Germany, Switzerland, France, Spain, Italy	India, Singapore, Malaysia, Vietnam	Australia, New Zealand	Other	Germany, Switzerland, France, Spain, Italy	India, Malaysia, Vietnam	Australia, New Zealand	Other	Germany, Switzerland, France, Spain, Italy	India, Singapore, Malaysia, Vietnam	Other	Germany, Switzerland, France	India	Lebanon, Nigeria, Algeria, Egypt, Jordan, Tunisia, Morocco	Other
PSHEZ0378QSZ1	1st lot	1st lot	1st lot		1st lot	1st lot	1st lot		1st lot	1st lot		1st lot	1st lot	1st lot	
PSHEZ0378QSZZ				1st lot				1st lot			1st lot				1st lot

No.28-2/2		捌きシート (Separation sheet)											
PARTS CODE	AR-5623 AR-5620 AR-5618	AR-5623D AR-5620D AR-5618D	AR-5623DA	AR-5620SL									
	ALL	ALL	Argentina	ALL									
PSHEZ0378QSZZ	1st lot	1st lot	1st lot	1st lot									

13 台板ユニット1(Base plate unit 1)

Matrix

No.41	ゴム足 (Rubber foot)												
PARTS CODE	AR-5618N			AR-5620S AR-5618S			AR-5618	AR-5618D	AR-5620SL				
	Germany, Switzerland, France, Spain, Italy	India, Singapore, Malaysia, Vietnam	Other	India, Germany, Switzerland, France	Lebanon, Nigeria, Algeria, Egypt, Jordan, Tunisia, Morocco	Other	ALL	ALL	ALL				
	1st lot	1st lot		1st lot	1st lot								
	GLEGG0064FCZZ												

13 台板ユニット 1(Base plate unit 1)

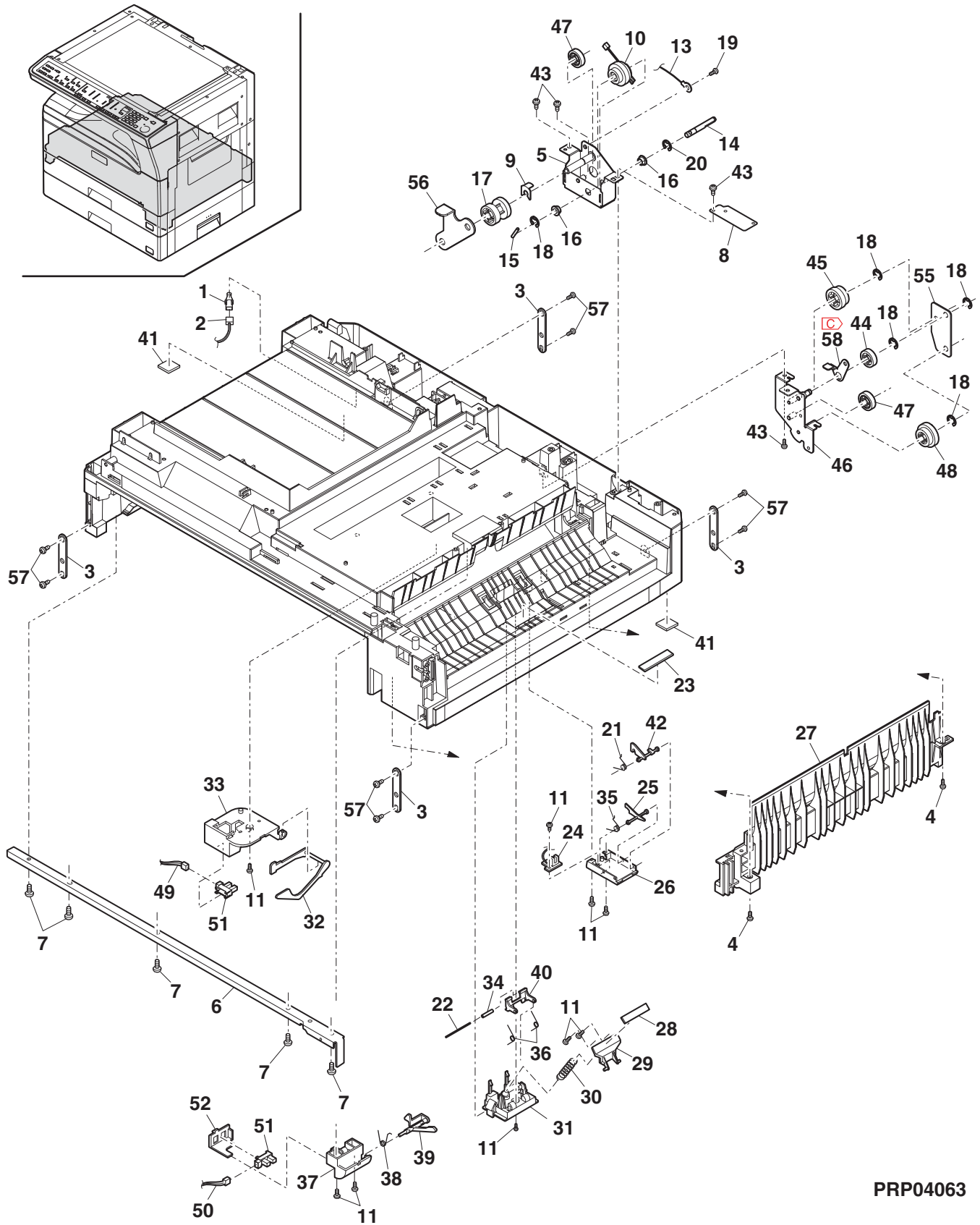

PRP04063

14 台板ユニット2(Base plate unit 2)

Matrix

No.16		DUP 電動機 (DUP motor)																
PARTS CODE	Germany, Switzerland, France, Spain, Italy, Australia, New Zealand	AR-5623N			AR-5620N			AR-5618N			AR-5623D	AR-5620D	AR-5618D	AR-5623DA				
		India, Singapore, Malaysia, Vietnam			Germany, Switzerland, France, Spain, Italy, Australia, New Zealand			India, Malaysia, Vietnam			India, Singapore, Malaysia, Vietnam, Germany, Switzerland, France, Spain, Italy			ALL	Argentina			
		Other			Other			Other			Other							
	1st lot	1st lot		1st lot	1st lot		1st lot			1st lot								
RM0TS0074QSPZ																		

No.501		DUP 駆動アイドルユニット (DUP drive idle unit)																
PARTS CODE	Germany, Switzerland, France, Spain, Italy, Australia, New Zealand	AR-5623N			AR-5620N			AR-5618N			AR-5623D	AR-5620D	AR-5618D	AR-5623DA				
		India, Singapore, Malaysia, Vietnam			Germany, Switzerland, France, Spain, Italy, Australia, New Zealand			India, Malaysia, Vietnam			India, Singapore, Malaysia, Vietnam, Germany, Switzerland, France, Spain, Italy			ALL	Argentina			
		Other			Other			Other			Other							
	1st lot	1st lot		1st lot	1st lot		1st lot			1st lot				1st lot	1st lot			
CPLTM0103RS53																		
CPLTM0103US53																		

15 台板ユニット3(Base plate unit 3)

NO.	PARTS CODE	Inter-change	PRICE RANK		NEW MARK	PART RANK	DESCRIPTION	TR No.	Effective time
			Ex.	Ja.					
1	LSOU-0052QSZZ		AY	FQ		C	Delivery tray(Refer to Matrix)		
	LSOU-0052QSZ1		AY	FQ		C	Delivery tray(Refer to Matrix)		
2	GCAB-0069QST2		AW	FG		D	Delivery rear cabinet		
3	XEBS740P10000		AA	DD		C	Screw(4x10)		
4	XHBS730P06000		AC	DD		C	Screw(3x6)		
5	LX-BZ0088QSPZ		AA	DD		C	Screw(3x6)		
6	LPLTM0425QSZ2		AR	EQ		C	MCU fixing plate(Refer to Matrix)		
	LPLTM0573QSZZ		AR	EQ		C	MCU fixing plate(Refer to Matrix)		
	CPWBX0252QS31		BZ	TR		E	MCU PWB(Refer to Matrix)		
	CPWBX0252QS32		BZ	TR		E	MCU PWB(Refer to Matrix)		
	CPWBX0252QS40		BZ	TR		E	MCU PWB(Refer to Matrix)		
	CPWBX0252QS41		BZ	TR		E	MCU PWB(Refer to Matrix)		
	CPWBX0252QS42		BZ	TR		E	MCU PWB(Refer to Matrix)		
	CPWBX0252QS33		BZ	TR		E	MCU PWB(Refer to Matrix)		
	CPWBX0252QS34		BZ	TR		E	MCU PWB(Refer to Matrix)		
	CPWBX0252QS35		BZ	TR		E	MCU PWB(Refer to Matrix)		
	CPWBX0252QS36		BZ	TR		E	MCU PWB(Refer to Matrix)		
	CPWBX0252QS38		BZ	TR		E	MCU PWB(Refer to Matrix)		
	CPWBX0252QS39		BZ	TR		E	MCU PWB(Refer to Matrix)		
	CPWBX0270QS32		CH	UP	N	E	MCU PWB(Refer to Matrix)		
8	LBNDJ0071FCZZ		AC	DJ		C	Band(RSG-100)		
9	RCORF0018QSZZ		AR	EQ		C	Core		
10	DHAi-0342QSZZ		AG	DX		C	CCD harness		
11	LHLDW0086QSZZ		AB	DJ		C	Harness ring		
12	LX-BZ0090QSPZ		AE	DD		C	Screw		
13	PSHEZ0694QSZZ		AC	DJ		C	MCU edge protect sheet N		
15	XHBS730P08000		AB	DD		C	Screw(3x8)		
17	XEBS730P10000		AC	DD		C	Screw(3x10)		
20	XEPS740P30000		AC	DD		C	Screw(4x30)	[120V]	
21	XEBS740P12000		AA	DD		C	Screw(4x12)	[120V]	
22	XWSS740-10000		AA	DD		C	Spring washer	[120V]	
23	XWHS740-08100		AA	DD		C	Washer	[120V]	
24	LFiX-0016FCZZ		AD	DJ		C	AC cord fixer C	[120V]	
25	LBNDJ0013FCZ1		AE	DJ		C	Band		
26	TCAUS0009QSZZ		AF	DS		C	Plug caution card	[Argentina]	
	DHAi-1212DS13		BD	GJ		B	AC code(Refer to Matrix)		
	QACCBR626QCPZ		AU	FG		B	AC code(Refer to Matrix)		
	QACCER622QCPZ		AQ	EQ		B	AC code(Refer to Matrix)		
	QACCFR620QCPZ		AX	FX		B	AC code(Refer to Matrix)		
	QACCLR622QCPZ		AR	EQ		B	AC code(Refer to Matrix)		
	QACCZR941QCPZ		BB	FX		B	AC code(Refer to Matrix)		
	QACCZR625QCPZ		AX	FG		B	AC code(Refer to Matrix)		
	QACCR7623QCPZ		BA	FX		B	AC code(Refer to Matrix)		
	QACCDR614QCPZ		AS	EQ		B	AC code(Refer to Matrix)		
28	NFANP0018QSPZ		AP	EQ		B	PS fan(Refer to Matrix)		
30	DUNTK0688RSZZ		AT	EZ		B	AC switch unit(Refer to Matrix)		
31	XBPS730P32KS0		AC	DD		C	Screw(3x32KS)		
33	LPLTM0428QSZ1		AR	EQ	N	C	PS PWB fixing plate	[Missing parts code]	
34	RDENC0038QSP2		BP	LP		E	Low voltage power supply unit(Refer to Matrix)		
35	XBPS730P08KS0		AB	DD		C	Screw(3x8KS)		
36	RDENU0041QSPZ		BX	RR		E	High voltage power supply unit		
37	XEBS730P08000		AC	DD		C	Screw(3x8)		
38	DHAi-0553QSP2		CK	UP		C	PS harness		
46	XBPSN40P06K00		AA	DD		C	Screw(4x6K)		
50	LPLTM0574QSZZ		AG	DX		C	Fan fixing plate		
51	PFiLZ0029QSZZ		BD	GN		A	Power supply dustproof filter		
52	TLABZ4868FCZ1		AB	DJ		D	Earth label	[200V series]	
	DUNT-0731RS12		AP	EQ		C	Inlet harness unit(Refer to Matrix)		
53	DUNT-0731US12	1	AY	FQ	N	C	Inlet harness unit(Refer to Matrix)		
54	LPLTM0585QSZZ		AF	DS		C	Inlet fixing plate	[200V series]	
55	XHSS730P06000		AB	DD		C	Screw	[200V series]	
56	DUNT-0742US11		BT	MW	N	E	NIC unit	[AR-5623N/5620N/5618N]	
57	RCORF0021QSZZ		AK	DX		C	Core		
60	LPLTM0426QSZ1		AF	DS		C	USB fixing plate	[AR-5620S/5618S/5623/5620/5618/5623D/5623DA/5620D/5618D/5620SL]	
61	DHAi-0560QSPZ		AH	DX		C	USB MCU harness	[AR-5620S/5618S/5623/5620/5618/5623D/5623DA/5620D/5618D/5620SL]	
62	CPWBN0219QS31		BH	HC		E	USB I/F PWB(Refer to Matrix)		
	CPWBN0219QSC1	1	AZ	FQ		E	USB I/F PWB(Refer to Matrix)		
63	PSHEZ0631QSZZ		AA	DJ		C	Optical mylar CHN	[AR-5620S/5618S/5623/5620/5618/5623D/5623DA/5620D/5618D/5620SL]	
							光学マイラ- CHN		11/06

15 台板ユニット3(Base plate unit 3)

Matrix

No.1	排紙トレイ (Delivery tray)																		
PARTS CODE	AR-5623N	AR-5620N	AR-5618N	AR-5623D	AR-5620D	AR-5618D	AR-5623DA	AR-5620S	AR-5618S	AR-5623	AR-5620	AR-5618	AR-5620SL						
	ALL	ALL	ALL	ALL	ALL	ALL	Argentina	ALL	ALL	ALL	ALL	ALL							
L SOU-0052QSZZ	1st lot	1st lot	1st lot																
L SOU-0052QSZ1								1st lot	1st lot	1st lot									

No.6	MCU 取付板 (MCU fixing plate)																		
PARTS CODE	AR-5623N	AR-5620N	AR-5618N	AR-5620S	AR-5618S	AR-5620SL	AR-5623	AR-5620	AR-5618	AR-5623D	AR-5620D	AR-5618D	AR-5623DA						
	ALL	ALL	ALL	ALL	ALL	ALL	ALL	ALL	ALL	ALL	ALL	ALL	Argentina						
L PLTM0425QSZ2	1st lot	1st lot	1st lot																
L PLTM0573QSZZ							1st lot	1st lot	1st lot										

No.7	MCU 基板 (MCU PWB)																		
PARTS CODE	AR-5623N	AR-5620N	AR-5618N	AR-5620S	AR-5618S	AR-5623	AR-5620	AR-5618	AR-5623D	AR-5623DA	AR-5620D	AR-5618D	AR-5620SL						
CPWBX0252QS31					1st lot														
CPWBX0252QS32				1st lot															
CPWBX0252QS40	1st lot																		
CPWBX0252QS41			1st lot																
CPWBX0252QS42		1st lot																	
CPWBX0252QS33								1st lot											
CPWBX0252QS34							1st lot												
CPWBX0252QS35												1st lot							
CPWBX0252QS36											1st lot								
CPWBX0252QS38						1st lot													
CPWBX0252QS39										1st lot									
CPWBX0270QS32													1st lot						

15 台板ユニット3(Base plate unit 3)

Matrix

No.27	AC ｺｰﾄﾞ (AC code)												
PARTS CODE	India			Yemen, Saudi Arabia, Bahrain, Kuwait, UAE, Oman, Qatar	Germany, Switzerland, France, Italy, Spain	Lebanon, Nigeria, Algeria, Egypt, Jordan, Tunisia, Morocco	Greece, Cyprus, Turkey, Poland, Hungary, Czech, Slovakia	Singapore, Malaysia, Vietnam	Australia, New Zealand	Thailand	Philippines	Argentina	Mexico, LAG2
	AR-5623N	AR-5620N	AR-5618N	AR-5620S	AR-5618S	Other	ALL	ALL	ALL	ALL	ALL	ALL	ALL
DHA i - 1 2 1 2 DS 1 3	1st lot	1st lot											
QACCBR6226QCPZ				1st lot									
QACCEFR622QCPZ					1st lot	1st lot	1st lot						
QACCFR620QCPZ								1st lot					
QACCLR622QCPZ									1st lot				
QACCZR941QCPZ										1st lot			
QACCZR625QCPZ											1st lot		
QACCR7623QCPZ												1st lot	
QACCDR614QCPZ													1st lot

No.28	PS ﾌｱﾝ (PS fan)												
PARTS CODE	AR-5623N	AR-5620N	AR-5618N	AR-5620S	AR-5618S	AR-5623	AR-5620	AR-5618	AR-5623D	AR-5620D	AR-5618D	AR-5623DA	AR-5620SL
	ALL	ALL	ALL	ALL	ALL	ALL	ALL	ALL	ALL	ALL	ALL	ALL	ALL
NFANP0018QSPZ	1st lot	1st lot											

No.30-1/2	AC スｲｯﾁ ﾕﾆｯﾄ (AC switch unit)														
PARTS CODE	AR-5623N			AR-5620N				AR-5618N			AR-5620S AR-5618S				
	Germany, Switzerland, France, Spain, Italy	India, Singapore, Malaysia, Vietnam	Australia, New Zealand	Other	Germany, Switzerland, France, Spain, Italy	India, Malaysia, Vietnam	Australia, New Zealand	Other	Germany, Switzerland, France, Spain, Italy	India, Singapore, Malaysia, Vietnam	Other	Germany, Switzerland, France	India	Lebanon, Nigeria, Algeria, Egypt, Jordan, Tunisia, Morocco	Other
DUNTK0688RSZZ	1st lot	1st lot	1st lot		1st lot	1st lot	1st lot		1st lot	1st lot		1st lot	1st lot	1st lot	

15 台板ユニット3(Base plate unit 3)

Matrix

No.30-2/2	ACスイッチユニット (AC switch unit)														
PARTS CODE	AR-5623	AR-5620	AR-5618	AR-5623D	AR-5620D	AR-5618D	AR-5623DA								
	ALL	ALL	ALL	ALL	ALL	ALL	Argentina	ALL							

No.34	低圧電源ユニット (Low voltage power supply unit)														
PARTS CODE	200V series	110V, 120V													
	RDENC0038QSP2	1st lot													

No.53-1/2	インレットハーネスユニット (Inlet harness unit)															
PARTS CODE	AR-5623N				AR-5620N				AR-5618N				AR-5620S AR-5618S			
	Germany, Switzerland, France, Spain, Italy	India, Singapore, Malaysia, Vietnam	Australia, New Zealand	Other	Germany, Switzerland, France, Spain, Italy	India, Malaysia, Vietnam	Australia, New Zealand	Other	Germany, Switzerland, France, Spain, Italy	India, Singapore, Malaysia, Vietnam	Other	Germany, Switzerland, France	India	Lebanon, Nigeria, Algeria, Egypt, Jordan, Tunisia, Morocco	Other	
DUNT-0731RS12	1st lot	1st lot	1st lot		1st lot	1st lot	1st lot		1st lot	1st lot		1st lot	1st lot	1st lot		
 DUNT-0731US12	Apr/11	Apr/11	Apr/11	1st lot	Apr/11	Apr/11	Apr/11	1st lot	Apr/11	Apr/11	1st lot	Apr/11	Apr/11	Apr/11	1st lot	

No.53-2/2	インレットハーネスユニット (Inlet harness unit)														
PARTS CODE	AR-5623	AR-5620	AR-5618	AR-5623D	AR-5620D	AR-5618D	AR-5623DA	AR-5620SL							
	200V series	200V series	200V series	200V series	200V series	200V series	200V series	200V series							
 DUNT-0731US12	1st lot	1st lot	1st lot	1st lot	1st lot										

15 台板ユニット3(Base plate unit 3)

Matrix

No.62	USB I/F 基板 (USB I/F PWB)																	
PARTS CODE	AR-5620S		AR-5618S		AR-5623	AR-5620	AR-5618	AR-5623D	AR-5620D	AR-5618D	AR-5623DA	AR-5620SL						
	Other	Singapore, Vietnam	Other	Vietnam	ALL	ALL	Argentina	ALL										
CPWBN0219QS31	1st lot		1st lot															
 CPWBN0219QSC1	Apr/11	1st lot	Apr/11	1st lot	1st lot	1st lot	1st lot	1st lot	1st lot									

15 台板ユニット 3(Base plate unit 3)

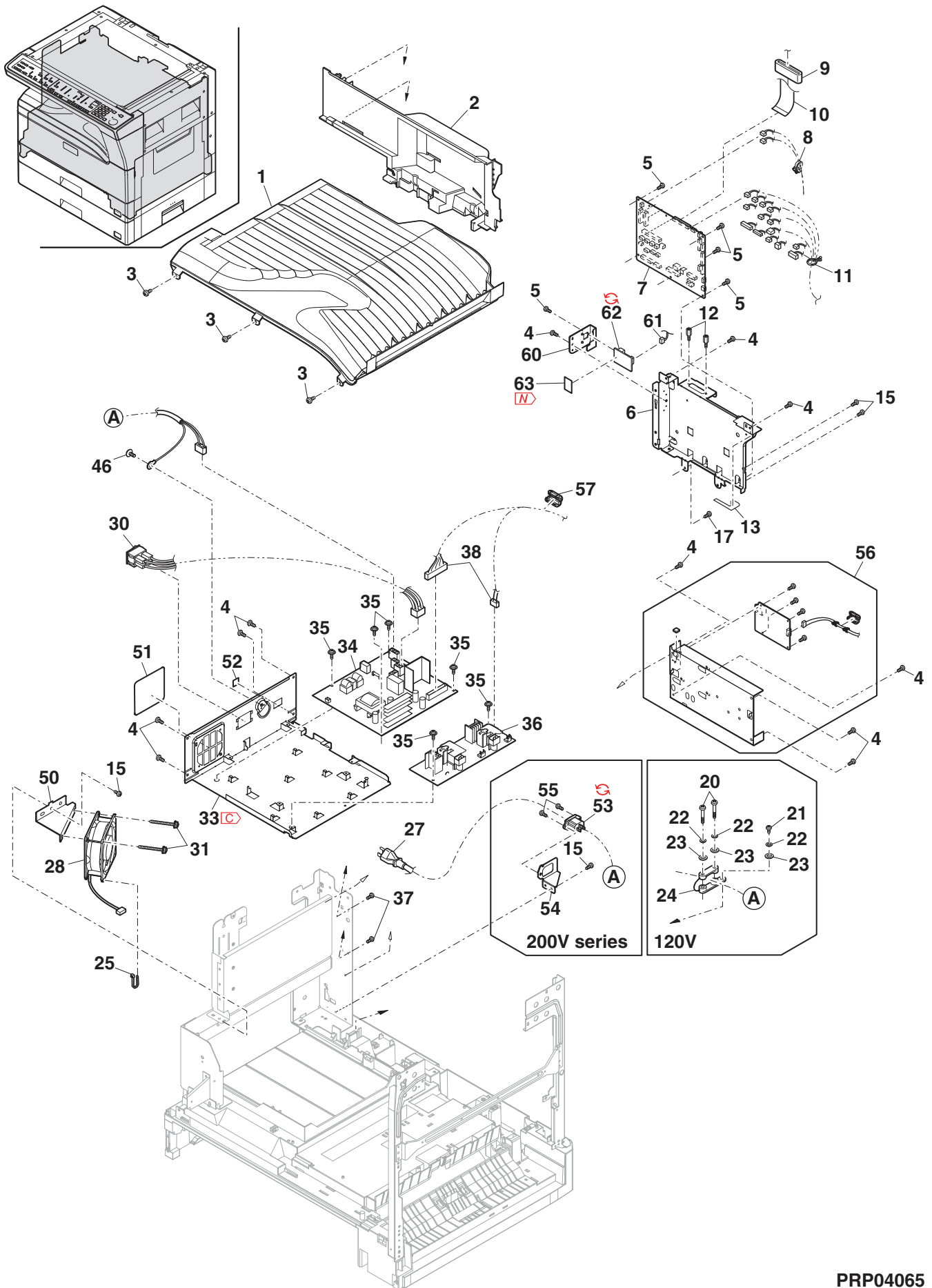

16 手差しマルチユニット (Manual paper feed multi unit)

NO.	PARTS CODE	Inter-change	PRICE RANK		NEW MARK	PART RANK	DESCRIPTION	TR No.	Effective time
			Ex.	Ja.					
1	PCOVP0098QST2		AL	EB		D	Multi frame cover	マルチフレームカバー	
2	MARMP0008QSZZ		AH	DX		C	Stopper arm	ストップアーム	
3	LPLTP0056QSZZ		AD	DJ		C	Stopper plate	ストップ板	
4	XRESP40-06000		AA	DD		C	E type ring(E4)	Eリング	
5	LBOSZ0199QSZZ		AE	DS		C	Cam boss A1	カムボス A1	
6	PPiPP0109FCZ1		AC	DJ		C	Manual paper feed clutch sleeve A pipe	手差しクラッチスリーブ Aパイプ	
7	MSPRC1315FCZ1		AD	DJ		C	Manual paper feed clutch spring A	手差しクラッチスプリング A	
8	XPSSJ20-07000		AA	DD		C	Spring pin	スプリングピン	
9	LBOSZ0150QSZZ		AE	DS		C	Cam boss A2N	カムボス A2N	
10	LBSHZ0303FCZZ		AC	DJ		C	M bushing C	Mブッシング C	
11	NSFTZ0096QSZZ		AF	DS		C	Roller shaft F_N	ローラシャフト F_N	
12	MSPRT0091QSZZ		AC	DJ		C	Roller arm spring	ローラアームスプリング	
13	NROLR0922FCZ2		AR	ZZ		C	Manual paper feed roller	手差しローラー	
14	NGERH0223QSZZ		AC	DJ		C	Manual paper feed pick up gear(20T)	手差し呼び込みギヤ	
15	NGERH0061QSZZ		AD	DJ		C	Gear(24T)	ギヤ	
16	MARMP0009QSZZ		AF	DS		C	Roller arm	ローラアーム	
17	NRÖLR1267FCZ1		AH	DX		C	Manual paper feed pick up roller	手差し呼び込みローラー	
18	XEBS730P10000		AC	DD		C	Screw(3×10)	ビス	
19	MARMP0041QSZZ		AE	DS		C	Cam transmission arm	カム伝達アーム	
20	MARMP0006QSZZ		AD	DJ		C	Lever arm	レバアーム	
21	NSFTZ0017QSP1		AD	DJ		C	Manual paper feed cam shaft	手差しカムシャフト	
22	MCAMP0001QSZZ		AF	DS		C	Drive cam	駆動カム	
23	MSPRC1316FCZ1		AE	DS		C	Manual paper feed clutch spring B	手差しクラッチスプリング B	
24	PPiPP0009QSZZ		AD	DJ		C	Cam clutch sleeve	カムクラッチスリーブ	
25	CPLTM0304QS03		AD	DS		C	Paper feed joint plate	給紙接続板	
26	PGiDM0187QSZZ		AK	DX		C	Multi frame cover guide	マルチフレームカバーガイド	
27	NGERH0972FCZZ		AB	DJ		C	Gear(27T)	ギヤ	
28	RPLU-0037QSZZ		BA	FX		B	Multi feeding solenoid	マルチフィードソレノイド	
29	MSPRC1318FCZ1		AA	DJ		C	Manual paper feed spring B	手差しスプリング B	
30	PTME-0179FCZZ		AC	DD		C	Manual paper feed latch B	手差しラッチ B	
31	PTME-0178FCZ1		AC	DJ		C	Manual paper feed latch A	手差しラッチ A	
32	MSPRC2175FCZZ		AA	DJ		C	Pawl A spring	爪 A スプリング	
34	XEBS730P10000		AA	DD		C	Screw(3×10)	ビス	
35	PSHEZ0099QSZZ		AC	DJ		C	Vibration proof sheet	防振シート	
36	MSPRT0147QSZZ		AC	DJ		C	Stopper arm spring	ストップアームスプリング	
37	PSHEZ0241QSZZ		AB	DJ		C	Vibration proof sheet C	防振シート C	
38	XEBS730P08000		AC	DD		C	Screw(3×8)	ビス	
39	LX-WZ0011QSZZ		AB	DD		C	Poly slider(5-12-0.5)	ポリスライダ	
40	PSHEZ0410QSZZ		AC	DJ		C	Manual paper feed protect mylar(Refer to Matrix)	手差し保護マイラ	
51	MARMP0005QSE1		AD	DJ		C	Tray arm	トレイアーム	
52	LSTPP0011QSZZ		AC	DJ		C	Stopper	ストップ	
53	LBSHZ0006QSZZ		AC	DJ		C	M bushing 2	Mブッシング 2	
54	NCPL-0012QSZZ		AD	DJ		C	Manual paper feed coupling	手差しカップリング	
55	MSPRD0302QSZZ		AC	DJ		C	Manual paper feed coupling spring	手差しカップリングスプリング	
56	NSFTZ0090QSZZ		AG	DX		C	Roller shaft R	ローラシャフト R	
58	CSOU-0009QS41		BA	FX		E	Manual paper feed tray unit(Refer to Matrix)	手差しトレイユニット	
	CSOU-0009QS43		AZ	FQ		E	Manual paper feed tray unit(Refer to Matrix)	手差しトレイユニット	
501	CFRM-0020RS5B		BD	GN		E	Manual paper feed multi unit(Refer to Matrix)	手差しマルチユニット	
	CFRM-0020US5B	1	BF	GN	N	E	Manual paper feed multi unit(Refer to Matrix)	手差しマルチユニット	11/04

16 手差しマルチユニット (Manual paper feed multi unit)

Matrix

No.40-1/2		手差し保護マliner (Manual paper feed protect mylar)													
PARTS CODE	AR-5623N			AR-5620N			AR-5618N			AR-5620S AR-5618S					
	Germany, Switzerland, France, Spain, Italy	India, Singapore, Malaysia, Vietnam	Australia, New Zealand	Other	Germany, Switzerland, France, Spain, Italy	India, Malaysia, Vietnam	Australia, New Zealand	Other	Germany, Switzerland, France, Spain, Italy	India, Singapore, Malaysia, Vietnam	Other	Germany, Switzerland, France	India	Lebanon, Nigeria, Algeria, Egypt, Jordan, Tunisia, Morocco	Other
	PSHEZ0410QSZZ	1st lot	1st lot	1st lot		1st lot	1st lot	1st lot		1st lot	1st lot		1st lot	1st lot	1st lot

No.40-2/2		手差し保護マliner (Manual paper feed protect mylar)													
PARTS CODE	AR-5623 AR-5620 AR-5618	AR-5623D AR-5620D AR-5618D	AR-5623DA	AR-5620SL											
	ALL	ALL	Argentina	ALL											

No.58-1/2		手差しトレイユニット (Manual paper feed tray unit)													
PARTS CODE	AR-5623N			AR-5620N			AR-5618N			AR-5620S AR-5618S					
	Germany, Switzerland, France, Spain, Italy	India, Singapore, Malaysia, Vietnam	Australia, New Zealand	Other	Germany, Switzerland, France, Spain, Italy	India, Malaysia, Vietnam	Australia, New Zealand	Other	Germany, Switzerland, France, Spain, Italy	India, Singapore, Malaysia, Vietnam	Other	Germany, Switzerland, France	India	Lebanon, Nigeria, Algeria, Egypt, Jordan, Tunisia, Morocco	Other
	CSOU-0009QS41	1st lot	1st lot	1st lot		1st lot	1st lot	1st lot		1st lot	1st lot		1st lot	1st lot	1st lot
	CSOU-0009QS43				1st lot				1st lot		1st lot				1st lot

No.58-2/2		手差しトレイユニット (Manual paper feed tray unit)													
PARTS CODE	AR-5623 AR-5620 AR-5618	AR-5623D AR-5620D AR-5618D	AR-5623DA	AR-5620SL											
	ALL	ALL	Argentina	ALL											
	CSOU-0009QS43	1st lot	1st lot	1st lot	1st lot										

16 手差しマルチユニット (Manual paper feed multi unit)

Matrix

No.501-1/2		手差しマルチユニット (Manual paper feed multi unit)														
PARTS CODE	CFRM-0020RS5B	AR-5623N				AR-5620N				AR-5618N			AR-5620S AR-5618S			
		Germany, Switzerland, France, Spain, Italy	India, Singapore, Malaysia, Vietnam	Australia, New Zealand	Other	Germany, Switzerland, France, Spain, Italy	India, Malaysia, Vietnam	Australia, New Zealand	Other	Germany, Switzerland, France, Spain, Italy	India, Singapore, Malaysia, Vietnam	Other	Germany, Switzerland, France	India	Lebanon, Nigeria, Algeria, Egypt, Jordan, Tunisia, Morocco	Other
	CFRM-0020US5B	1st lot	1st lot	1st lot	1st lot	1st lot	1st lot	1st lot	1st lot	1st lot	1st lot	1st lot	1st lot	1st lot	1st lot	1st lot
	CFRM-0020US5B	Apr/11	Apr/11	Apr/11	1st lot	Apr/11	Apr/11	Apr/11	1st lot	Apr/11	Apr/11	1st lot	Apr/11	Apr/11	Apr/11	1st lot

No.501-2/2		手差しマルチユニット (Manual paper feed multi unit)														
PARTS CODE	CFRM-0020US5B	AR-5623	AR-5620	AR-5618	AR-5623D	AR-5620D	AR-5618D	AR-5623DA	AR-5620SL							
		ALL	ALL	ALL	Argentina	ALL										
	CFRM-0020US5B	1st lot	1st lot	1st lot	1st lot	1st lot										

16 手差しマルチユニット (Manual paper feed multi unit)

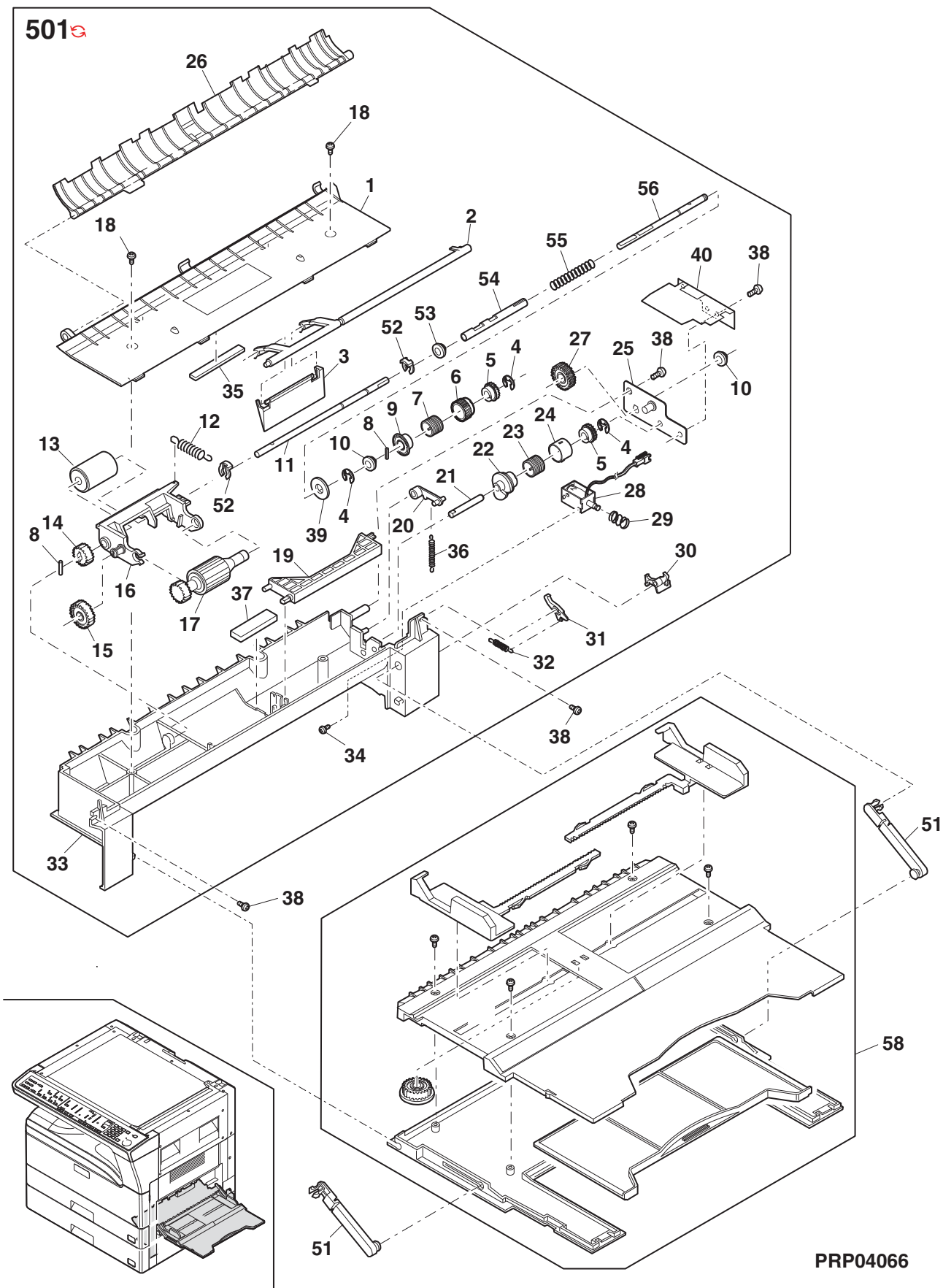

17 排紙フレームユニット (Delivery frame unit)[AR-5620S/5618S/5623/5620/5618/5620SL]

NO.	PARTS CODE	Inter-change	PRICE RANK		NEW MARK	PART RANK	DESCRIPTION	TR No.	Effective time
			Ex.	Ja.					
1	PBRSS0026QSZZ		AF	DS		B	Discharge brush 除電ブラシ		
2	XEBS730P08000		AC	DD		C	Screw(3x8) ビス		
3	CPWBF0147QSE9		AP	EQ		E	DUP/P-OUT sensor PWB(Refer to Matrix) DUP/P-OUT センサ基板		
	CPWBF0191US54		AT	EZ		E	DUP/P-OUT sensor PWB(Refer to Matrix) DUP/P-OUT センサ基板		
4	NR0LM0179QSZZ		AN	EG		B	Delivery roller 排紙ローラー		
5	MLEVP0025QSZZ		AD	DJ		C	Delivery actuator 排紙アクチュエーター		
7	LFRM-0105QSZZ		AR	EQ		C	Delivery frame upper(Refer to Matrix) 排紙フレーム上		
8	NBRGM0501FCZZ		AB	DJ		C	Bearing 軸受		
9	NPLYZ0029QSZZ		AD	DJ		C	Delivery drive gear(34T) 排紙駆動ギヤ		
10	XRESP50-06000		AA	DD		C	E type ring(E5) Eリング		
11	MSPRD0297QSZZ		AG	DX		C	Delivery earth spring(Refer to Matrix) 排紙アースリング		
	MSPRD0473QSZZ		AD	DJ		C	Delivery earth spring(Refer to Matrix) 排紙アースリング		
12	NFANP0021QSPZ		AP	EQ		B	Cooling fan(Refer to Matrix) ケーリングファン		
13	LX-BZ0030QSPZ		AC	DD		C	Screw(2x6) ビス		
14	PFILZ0017QSZ1		AP	EQ		A	Ozone filter VOC2 オゾンフィルター VOC2		
17	MSPRT0229GCAZ		AC	DJ		C	FU spring R FUスプリング R		
18	NR0LP0122QSZZ		AH	DX		C	Delivery follower roller A 排紙従動ローラー A		
19	NKOM-0002QSZZ		AC	DJ		C	Delivery collar 排紙コロ		
20	LFRM-0112QSZZ		AV	FG		C	Delivery frame lower 排紙フレーム下		
21	LPLTP0385QSZZ		AD	DJ		C	Delivery fixing plate 排紙押えプレート		
24	PSPO-0034QSZZ		AC	DD		C	Delivery cushion(Refer to Matrix) 蹴出しスポンジ		
	PSPO-0030QSZZ		AC	DJ		C	Delivery cushion(Refer to Matrix) 蹴出しスポンジ		
25	PSHEZ0710QSZZ		BD	GN		C	Delivery fan mylar 排紙ファンマイラー		
	(Unit)								
901	CFRM-0112RS51		BF	GN		E	Delivery frame unit(Refer to Matrix) 排紙フレームユニット		
	CFRM-0112US51	1	BH	HC	N	E	Delivery frame unit(Refer to Matrix) 排紙フレームユニット		
	CFRM-0112US53		BH	HC	N	E	Delivery frame unit(Refer to Matrix) 排紙フレームユニット		

Matrix

No.3	DUP/P-OUT センサ基板 (DUP/P-OUT sensor PWB)																			
PARTS CODE	India, Germany, Switzerland, France		AR-5620S AR-5618S		AR-5623	AR-5620	AR-5618	AR-5620SL												
	Lebanon, Nigeria, Algeria, Egypt, Jordan, Tunisia, Morocco		Other		ALL	ALL														
CPWBF0147QSE9	1st lot	1st lot																		
CPWBF0191US54			1st lot	1st lot	1st lot															

No.7	排紙フレーム上 (Delivery frame upper)																			
PARTS CODE	AR-5620S AR-5618S		AR-5623 AR-5620 AR-5618		AR-5620SL															
	ALL		ALL		ALL															
LFRM-0105QSZZ	1st lot	1st lot																		

17 排紙フレームユニット (Delivery frame unit)[AR-5620S/5618S/5623/5620/5618/5620SL]

Matrix

No.11		排紙アースリング (Delivery earth spring)																
PARTS CODE		AR-5620S AR-5618S			AR-5623	AR-5620	AR-5618	AR-5620SL										
	Other	India, Germany , Switzerland, France	Lebanon, Nigeria, Algeria, Egypt, Jordan, Tunisia, Morocco		ALL	ALL												
MSPRD0297QSZ1	1st lot				1st lot	1st lot												
MSPRD0473QSZZ		1st lot	1st lot															

No.12		クーリングファン (Cooling fan)																
PARTS CODE		AR-5620S	AR-5618S	AR-5623	AR-5620	AR-5618	AR-5620SL											
	ALL	ALL	ALL	ALL	ALL													
NFANP0021QSPZ	1st lot																	

No.24		蹴出しホップ (Delivery cushion)																
PARTS CODE		AR-5620S	AR-5618S	AR-5623	AR-5620	AR-5618	AR-5620SL											
	ALL	ALL	ALL	ALL	ALL	ALL												
PSPO-0034QSZZ			1st lot															
PSPO-0030QSZZ	1st lot			1st lot	1st lot													

No.901		排紙フレームユニット (Delivery frame unit)																
PARTS CODE		AR-5620S AR-5618S			AR-5623	AR-5620	AR-5618	AR-5620SL										
	India, Germany , Switzerland, France	Lebanon, Nigeria, Algeria, Egypt, Jordan, Tunisia, Morocco		Other	ALL	ALL	ALL											
CFRM-0112RS51	1st lot	1st lot																
CFRM-0112US51	Apr/11	Apr/11	1st lot		1st lot													
CFRM-0112US53				1st lot														

17 排紙フレームユニット (Delivery frame unit)[AR-5620S/5618S/5623/5620/5618/5620SL]

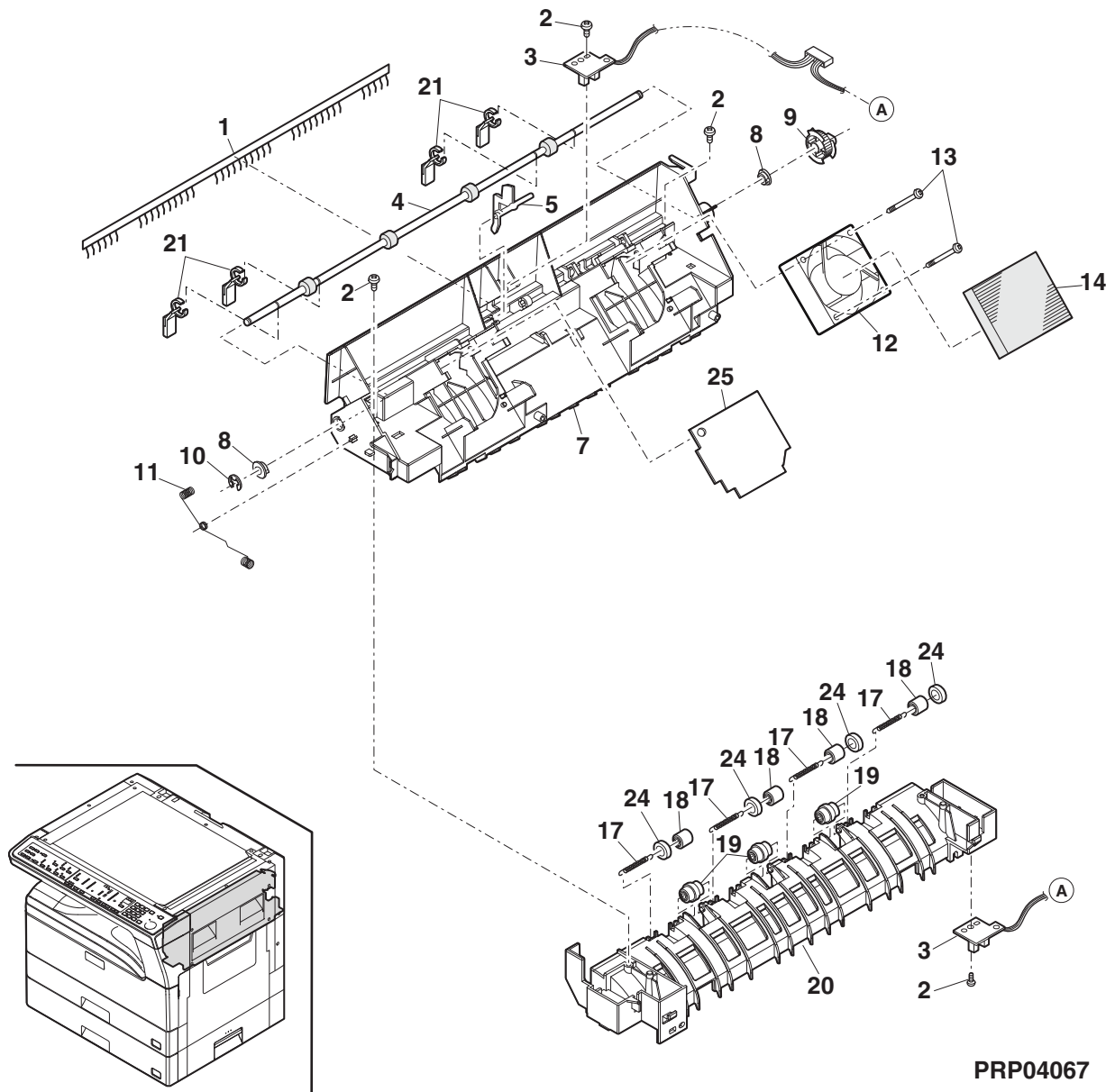

18 排紙フレームユニット (Delivery frame unit)[AR-5623N/5620N/5618N/5623D/5623DA/5620D/5618D]

NO.	PARTS CODE	Inter-change	PRICE RANK		NEW MARK	PART RANK	DESCRIPTION	TR No.	Effective time
			Ex.	Ja.					
1	XEBS730P08000		AC	DD		C	Screw(3×8)		ビス
2	GCOV-0049QST3		AN	EG		D	Delivery front cover		排紙前カバー
5	PSPO-0034QSZZ		AC	DD		C	Delivery cushion		蹴出しスポンジ
6	NRÖLM0180QSZZ		AN	EG		C	Delivery roller PEGLC		排紙ローラー PEGLC
7	MSPRT0229GCAZ		AC	DJ		C	FU spring R		FUスプリング R
8	NROLP0123QSZZ		AH	DX		C	Delivery follower roller B		排紙従動ローラー B
9	NKOM-0002QSZZ		AC	DJ		C	Delivery collar		排紙コロ
11	PBRSR0005QSZZ		AK	EB		B	Discharge brush		除電ブラシ
12	XRESP50-06000		AA	DD		C	E type ring(E5)		Eリング
13	NBRGC0529FCZZ		AD	DJ		C	Bearing		軸受
14	LPLTM0100QSZ1		AD	DJ		C	Delivery earth plate B		排紙アース板 B
16	LHLDZ0040QSZ3		AN	EG		C	Delivery follower roller holder		排紙従動 ローラーホルダー
22	NROLP0122QSZZ		AH	DX		C	Delivery follower roller A		排紙従動ローラー A
23	LPLTP0385QSZZ		AD	DJ		C	Delivery fixing plate		排紙押えプレート
28	MLEVP0025QSZ2		AD	DJ		C	Delivery actuator		排紙アクチュエーター
29	CPWBF0147QSE2		AP	EQ		E	DUP/P-OUT sensor PWB(Refer to Matrix)		DUP/P-OUT センサー基板
	CPWBF0191US51		AS	EQ		E	DUP/P-OUT sensor PWB(Refer to Matrix)		DUP/P-OUT センサー基板
30	MSPRD0143QSZ1		AF	DS		C	Delivery earth spring A		排紙アース スプリング A
31	NGERH0063QSZZ		AD	DJ		C	Delivery drive gear(30T)		排紙駆動ギヤ
32	LPINS0258FCZZ		AA	DD		C	Spring pin(φ3-8)		スプリングピン
33	NBRGC0019QSZZ		AD	DJ		C	Bearing(φ6)		軸受
34	XRESP40-06000		AA	DD		C	E type ring(E4)		Eリング
35	NGERH0070QSZZ		AC	DJ		C	DUP delivery R gear(20T)		DUP 排紙 R ギヤ
36	XPSSJ20-10000		AA	DD		C	Spring pin(φ2-10)		スプリングピン
37	NBRGY2122SCZZ		AB	DD		C	Transport roller bearing 1		搬送ローラー ベアリング 1
38	NROLP0038QSZZ		AP	EQ		C	DUP delivery roller		DUP 排紙ローラー
39	LFRM-0027QSZ3		AV	FG		C	Delivery frame(Refer to Matrix)		排紙フレーム
	LFRM-0027QSZ4		AV	FG		C	Delivery frame(Refer to Matrix)		排紙フレーム
40	PFILZ0017QSZ1		AP	EQ		A	Ozone filter VOC2		オゾンフィルター VOC2
41	PMLT-0099QSZZ		AC	DJ		C	Cooling fan cushion	[AR-5623N/5620N/5618N]	クーリングファンホルダー
42	LX-BZ0095QSZZ		AA	DD		C	Screw(2×6)	[AR-5623N/5620N/5618N]	ビス
43	NFANP0019QSPZ		AQ	EQ		B	Cooling fan(Refer to Matrix)		クーリングファン
44	PDUC-0008QSZZ		AG	DX		C	Cooling fan duct	[AR-5623N/5620N/5618N]	クーリングファンダクト
45	PGiDM0062QSZ3		AK	EB		C	Delivery upper paper guide 20(Refer to Matrix)		排紙上ペーパー ガイド 20
	PGiDM0062QSZ4		AK	EB		C	Delivery upper paper guide 20(Refer to Matrix)		排紙上ペーパー ガイド 20
46	NROLP1122FCZZ		AF	DS		C	PS upper roller		PS 上ローラー
47	PGiDM0199QSZZ		AV	FG		C	Delivery lower paper guide		排紙下ペーパー ガイド
48	LHLDZ0168QSZZ					C	Fan holder	[AR-5623D/5623DA/5620D/5618D]	ファンホルダー
72	LHLDW0086QSZZ		AB	DJ		C	Harness ring	[AR-5623N/5620N/5618N]	ハーネスリング
75	PSHEZ0710QSZZ		BD	GN		C	Delivery fan mylar		排紙ファンマイラー
501	CHLDZ0040RS63		AX	FG		E	Delivery holder(Refer to Matrix)		排紙ホルダー
	CHLDZ0040RS68		AX	FG		E	Delivery holder(Refer to Matrix)		排紙ホルダー
	CHLDZ0040US68	1	AZ	FX	N	E	Delivery holder(Refer to Matrix)		排紙ホルダー
	(Unit)								
901	DUNT-0964RSZZ		BH	GX		E	Delivery frame unit(Refer to Matrix)		排紙フレームユニット
	DUNT-0964RS13		BH	GX		E	Delivery frame unit(Refer to Matrix)		排紙フレームユニット
	DUNT-0964US13	1	BM	HR	N	E	Delivery frame unit(Refer to Matrix)		排紙フレームユニット

18 排紙フレームユニット (Delivery frame unit)[AR-5623N/5620N/5618N/5623D/5623DA/5620D/5618D]

Matrix

No.29		DUP/P-OUT センサ基板 (DUP/P-OUT sensor PWB)															
PARTS CODE	AR-5623N			AR-5620N			AR-5618N			AR-5623D	AR-5620D	AR-5618D	AR-5623DA				
	India, Singapore, Malaysia, Vietnam	Germany, Switzerland, France, Spain, Italy, Australia, New Zealand	Other	India, Malaysia, Vietnam	Germany, Switzerland, France, Spain, Italy, Australia, New Zealand	Other	Germany, Switzerland, France, Spain, Italy	India, Singapore, Malaysia, Vietnam	Other	ALL	Argentina						
CPWBF0147QSE2	1st lot	1st lot		1st lot	1st lot		1st lot	1st lot		1st lot	1st lot	1st lot					
CPWBF0191US51			1st lot			1st lot			1st lot				1st lot				

No.39		排紙フレーム (Delivery frame)															
PARTS CODE	AR-5623N			AR-5620N			AR-5618N			AR-5623D	AR-5620D	AR-5618D	AR-5623DA				
	India, Singapore, Malaysia, Vietnam	Germany, Switzerland, France, Spain, Italy, Australia, New Zealand	Other	India, Malaysia, Vietnam	Germany, Switzerland, France, Spain, Italy, Australia, New Zealand	Other	Germany, Switzerland, France, Spain, Italy	India, Singapore, Malaysia, Vietnam	Other	ALL	Argentina						
LFRM-0027QSZ3	1st lot	1st lot		1st lot	1st lot		1st lot	1st lot		1st lot	1st lot	1st lot					
LFRM-0027QSZ4			1st lot			1st lot			1st lot				1st lot				

No.43		クーリングファン (Cooling fan)															
PARTS CODE	AR-5623N	AR-5620N	AR-5618N	AR-5623D	AR-5620D	AR-5618D	AR-5623DA										
	ALL	ALL	Argentina														
NFANP0019QSPZ	1st lot																

18 排紙フレームユニット (Delivery frame unit)[AR-5623N/5620N/5618N/5623D/5623DA/5620D/5618D]

Matrix

No.45		排紙上ハ - ハ - ガ イ ト 20(Delivery upper paper guide 20)															
PARTS CODE		AR-5623N			AR-5620N			AR-5618N			AR-5623D	AR-5620D	AR-5618D	AR-5623DA			
		India, Singapore, Malaysia, Vietnam	Germany, Switzerland, France, Spain, Italy, Australia, New Zealand	Other	India, Malaysia, Vietnam	Germany, Switzerland, France, Spain, Italy, Australia, New Zealand	Other	Germany, Switzerland, France, Spain, Italy	India, Singapore, Malaysia, Vietnam	Other	ALL	ALL	Argentina				
	PG i DM0062QSZ3	1st lot	1st lot		1st lot	1st lot		1st lot	1st lot		1st lot	1st lot	1st lot				
	PG i DM0062QSZ4			1st lot			1st lot			1st lot							

No.501		排紙ホルダ - (Delivery holder)															
PARTS CODE		AR-5623N			AR-5620N			AR-5618N			AR-5623D	AR-5620D	AR-5618D	AR-5623DA			
		Germany, Switzerland, France, Spain, Italy, Australia, New Zealand	India, Singapore, Malaysia, Vietnam	Other	Germany, Switzerland, France, Spain, Italy, Australia, New Zealand	India, Malaysia, Vietnam	Other	Germany, Switzerland, France, Spain, Italy	India, Singapore, Malaysia, Vietnam	Other	ALL	ALL	Argentina				
	CHLDZ0040RS63	1st lot	1st lot														
	CHLDZ0040RS68				1st lot	1st lot		1st lot	1st lot		1st lot	1st lot	1st lot				
 CHLDZ0040US68			1st lot		Apr/11	Apr/11	1st lot	Apr/11	Apr/11	1st lot	1st lot	1st lot					

No.901		排紙フレームユニット (Delivery frame unit)															
PARTS CODE		AR-5623N			AR-5620N			AR-5618N			AR-5623D	AR-5620D	AR-5618D	AR-5623DA			
		Germany, Switzerland, France, Spain, Italy, Australia, New Zealand	India, Singapore, Malaysia, Vietnam	Other	Germany, Switzerland, France, Spain, Italy, Australia, New Zealand	India, Malaysia, Vietnam	Other	Germany, Switzerland, France, Spain, Italy	India, Singapore, Malaysia, Vietnam	Other	ALL	ALL	Argentina				
	DUNT-0964RSZZ	1st lot	1st lot														
	DUNT-0964RS13				1st lot	1st lot		1st lot	1st lot								
 DUNT-0964US13			1st lot		Apr/11	Apr/11	1st lot	Apr/11	Apr/11	1st lot							

18 排紙フレームユニット (Delivery frame unit)[AR-5623N/5620N/5618N/5623D/5623DA/5620D/5618D]

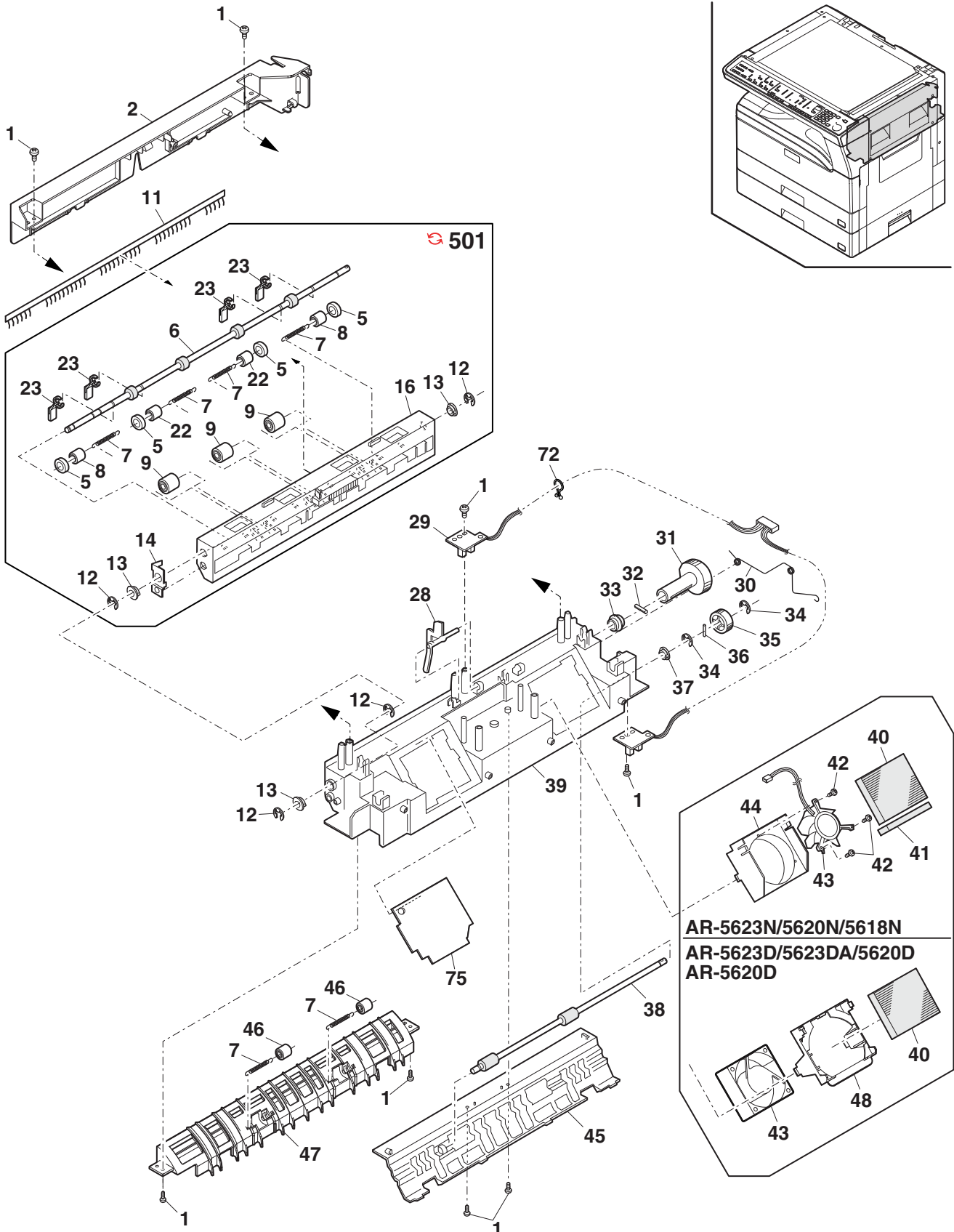

AR-5623N/5620N/5618N
AR-5623D/5623DA/5620D
AR-5620D

PRP04068

19 TC ケースユニット (TC case unit)

NO.	PARTS CODE	Inter-change	PRICE RANK		NEW MARK	PART RANK	DESCRIPTION	TR No.	Effective time
			Ex.	Ja.					
1	XEBS730P08000		AC	DD		C	Screw(3x8) ビス		
2	PGIDH0200QSZZ		BD	GN		C	TC front guide(Refer to Matrix) TC 前ガイド		
2	PGIDH0200QSZ1	1	AK	DX		C	TC front guide(Refer to Matrix) TC 前ガイド		
3	PSHEP0050QSZ1		AD	DJ		C	TC mylar TC マイラー		
4	PSHEZ0435QSZ1		AA	DJ		C	Guide mylar ガイドマイラー		
5	PSHEP0051QSZZ		AB	DJ		C	TC cover mylar F TC カバーマイラー F		
6	LHLDZ0030QSZZ		AD	DJ		C	TC holder F TC ホルダー F		
8	MSPRT0513FCZ1		AA	DJ		C	MC tension spring MC テンションスプリング		
9	PSHEP0052QSZZ		AB	DJ		C	TC cover mylar R TC カバーマイラー R		
10	LHLDZ0032QSZZ		AD	DJ		C	TC holder R TC ホルダー R		
11	QSLP-0009QSZ1		AD	DJ		B	TC electrode plate TC 電極板		
12	PCASZ0013QSZZ		AP	EQ		D	TC case TC ケース		
13	LHLDZ0031QSZ4		AH	DX		C	Discharge holder 除電ホルダー		
14	QSLP-0008QSZ1		AD	DJ		B	BC electrode plate BC 電極板		
15	PSPAZ0040QSZZ		AB	DJ		C	Front guide spacer 前ガイドスペーサー		
16	PGIDM0032QSZZ		AE	DS		C	Separator guide 剥離ガイド		
17	XEBS730P06000		AA	DD		C	Screw(3x6) ビス		
19	PSHEZ0125QSZZ		AE	DS		C	Discharger delivery sheet 除電排紙シート		
20	PSHEZ0434QSZZ		AC	DJ		C	TC case mylar TC ケースマイラー		
21	RR-HZ226JFCPZ		AD	DJ		C	Resistor 抵抗		
22	XBPSC30P06ES0		AA	DD		C	Screw(3x6ES) ビス		
	(Unit)								
901	CHLDZ0030RS57		BE	GN		E	TC case unit(Refer to Matrix) TC ケースユニット		
901	CHLDZ0030US57	1	BB	GD	N	E	TC case unit(Refer to Matrix) TC ケースユニット		11/04

Matrix

No.2-1/2	TC 前ガイド (TC front guide)															
PARTS CODE	AR-5623N				AR-5620N				AR-5618N				AR-5620S AR-5618S			
	Germany, Switzerland, France, Spain, Italy	India, Singapore, Malaysia, Vietnam	Australia, New Zealand	Other	Germany, Switzerland, France, Spain, Italy	India, Malaysia, Vietnam	Australia, New Zealand	Other	Germany, Switzerland, France, Spain, Italy	India, Singapore, Malaysia, Vietnam	Other	Germany, Switzerland, France	India	Lebanon, Nigeria, Algeria, Egypt, Jordan, Tunisia, Morocco	Other	
PGIDH0200QSZZ	1st lot	1st lot	1st lot		1st lot	1st lot	1st lot		1st lot	1st lot		1st lot	1st lot	1st lot		
PGIDH0200QSZ1	Mar/11	Mar/11	Mar/11	1st lot	Mar/11	Mar/11	Mar/11	1st lot	Mar/11	Mar/11	1st lot	Mar/11	Mar/11	Mar/11	1st lot	

No.2-2/2	TC 前ガイド (TC front guide)														
PARTS CODE	AR-5623	AR-5620	AR-5618	AR-5623D	AR-5620D	AR-5618D	AR-5623DA	AR-5620SL							
	ALL	ALL	ALL	ALL	ALL	ALL	Argentina	ALL							
PGIDH0200QSZ1	1st lot	1st lot	1st lot	1st lot	1st lot	1st lot	1st lot	1st lot							

19 TC ケースユニット (TC case unit)

Matrix

No.901-1/2		TC ケースユニット (TC case unit)													
PARTS CODE	AR-5623N				AR-5620N				AR-5618N			AR-5620S AR-5618S			
	Germany, Switzerland, France, Spain, Italy	India, Singapore, Malaysia, Vietnam	Australia, New Zealand	Other	Germany, Switzerland, France, Spain, Italy	India, Malaysia, Vietnam	Australia, New Zealand	Other	Germany, Switzerland, France, Spain, Italy	India, Singapore, Malaysia, Vietnam	Other	Germany, Switzerland, France	India	Lebanon, Nigeria, Algeria, Egypt, Jordan, Tunisia, Morocco	Other
CHLDZ0030RS57	1st lot	1st lot	1st lot		1st lot	1st lot	1st lot		1st lot	1st lot		1st lot	1st lot	1st lot	
CHLDZ0030US57	Apr/11	Apr/11	Apr/11	1st lot	Apr/11	Apr/11	Apr/11	1st lot	Apr/11	Apr/11	1st lot	Apr/11	Apr/11	Apr/11	1st lot

No.901-2/2		TC ケースユニット (TC case unit)													
PARTS CODE	AR-5623	AR-5620	AR-5618	AR-5623D	AR-5620D	AR-5618D	AR-5623DA	AR-5620SL							
	ALL	ALL	ALL	ALL	ALL	ALL	Argentina	ALL							
CHLDZ0030US57	1st lot	1st lot	1st lot	1st lot	1st lot	1st lot	1st lot	1st lot							

20 250 枚トレイユニット (250 sheets tray unit)

NO.	PARTS CODE	Inter-change	PRICE RANK		NEW MARK	PART RANK	DESCRIPTION	TR No.	Effective time
			Ex.	Ja.					
1	LPLTM0533USZZ		BE	GN		C	Rotation plate(Refer to Matrix)	回転板	
	LPLTM0533QSZZ	1	AT	EZ		C	Rotation plate(Refer to Matrix)	回転板	
2	MSPRP0427QSZZ		AD	DD		C	Cassette earth plate	カセットアース板	
3	PSHEZ0728QSZZ		AF	DS		C	Rotation sheet	回転シート	
4	PGIDM0188USZZ		AL	EB		C	Guide F(Refer to Matrix)	ガイド F	
	PGIDM0188QSZZ	1	AL	EB		C	Guide F(Refer to Matrix)	ガイド F	
5	PGIDM0189USZZ		AL	EB		C	Guide R(Refer to Matrix)	ガイド R	
	PGIDM0189QSZZ	1	AL	EB		C	Guide R(Refer to Matrix)	ガイド R	
6	XEBS730P08000		AC	DD		C	Screw(3×8)	ビス	
7	XWHS730-08100		AA	DD		C	Washer	ワッシャー	
8	NGERH0193FCZZ		AB	DD		C	Manual paper feed gear	手差しギヤ	
9	MSPRC0090QSZZ		AD	DJ		C	Cassette spring	カセットスプリング	
10	NBRGP0037USZZ		AL	EB		C	Bearing R(Refer to Matrix)	軸受 R	
	NBRGP0037QSZZ	1	AC	DD		C	Bearing R(Refer to Matrix)	軸受 R	
11	MSPRC0430QSZZ		AC	DJ		C	Cassette joint gear spring	カセット連結ギヤスプリング	
12	NGERH0249QSZZ		AC	DD		C	Cassette joint gear	カセット連結ギヤ	
13	LPINS0157FCZZ		AB	DD		C	Pin	ピン	
14	PSHEZ0712QSZZ		AG	DX		C	Separation sheet	カバキシート	
15	LPLTP0588QSZZ		AD	DJ		C	Separation plate	カバキプレート	
16	MSPRC0478QSAZ		AC	DD	N	C	Separation spring(Refer to Matrix)	カバキスプリング	
	LSTPP0020USZZ		AL	EB		C	Rotation plate stopper(Refer to Matrix)	回転板ストッパー	
	LSTPP0020QSZZ	1	AC	DJ		C	Rotation plate stopper(Refer to Matrix)	回転板ストッパー	
18	NSFTZ0118QSZ1		AV	FG		C	Paper feed shaft	給紙軸	
19	XPSSJ30-12000		AB	DD		C	Spring pin(3×12)	スプリングピン	
20	NROLR0170QSZZ		AN	EQ		C	Paper feed roller	給紙ローラー	
21	GCOV-0087USZZ		AZ	FQ		D	Cassette panel(1st)	カセットパネル	
22	GCOV-0091QSZZ		AX	FG		D	2nd cassette panel(2nd) [AR-5623N/5620N/5623/5620/5623D/5623DA/5620D]	2nd カセットパネル	
23	PCOVP0114QSZ1		AD	DJ		D	Handle cover(Refer to Matrix)	取手カバー	
24	LPLTM2642FCG2		AD	DJ		C	Tray rear edge plate	トレイ後端板	
25	GCASP0009USZZ		BB	FX		D	Cassette case(Refer to Matrix)	カセットケース	
	GCASP0009QSZZ	1	BB	FX		D	Cassette case(Refer to Matrix)	カセットケース	
26	MSPRC1145FCZZ		AA	DD		C	Stopper spring	ストッパー用スプリング	
27	MSPRC0152QSZZ		AB	DJ		C	Cassette ejection spring D(Refer to Matrix)	カセット押し出しスプリング D	
28	MSPRC0437QSZZ		AC	DJ		C	Cassette earth spring	カセットアーススプリング	
29	NBRGP0036USZZ		AL	EB		C	Bearing F(Refer to Matrix)	軸受 F	
	NBRGP0036QSZZ	1	AC	DD		C	Bearing F(Refer to Matrix)	軸受 F	
30	LHLDZ0155QSZZ		AD	DD		C	Regulation plate spring holder	規制板バネホルダー	
32	TTAG-0009QSZZ		AC	DJ		D	Cassette tag	カセットタグ	
33	LHLDW1226FCZZ		AB	DJ		C	Turn fastener	ターンファスナー	
34	XEBS740P10000		AA	DD		C	Screw(4×10)	ビス	
35	XEBS730P06000		AA	DD		C	Screw(3×6)	ビス	
36	LX-NZ0111FCZZ		AA	DD		C	M3 plate nut	M3 板ナット	
37	NBRGP0043USZZ		AD	DD		C	Cassette fixing bearing(Refer to Matrix)	カセット押え軸受	
	NBRGP0043QSZZ	1	AC	DD		C	Cassette fixing bearing(Refer to Matrix)	カセット押え軸受	
38	MSPRC3402FCZZ		AC	DJ		C	Spring	スプリング	
39	LPLTM0558QSZZ	-	AD	DJ	N	C	Separation guide plate [Missing parts code]	カバキガイド板	
40	XBBS730P06000		AC	DD		C	Screw(3×6)	ビス	
41	NROLP0178QSZZ		AD	DJ		C	Paper feed support collar	給紙補助コリ	
42	TLABH0864QSZZ	-	AE	DJ		D	Cassette caution label	カセット注意ラベル	11/07 R/C
	(Unit)								
901	CCASP0009RS53		BM	HV		E	250 sheets tray unit(1st)(Refer to Matrix)(Except No.22)	250 枚トレイユニット	
	CCASP0009US53	1	BM	HR	N	E	250 sheets tray unit(1st)(Refer to Matrix)(Except No.22)	250 枚トレイユニット	
902	CCASP0009RS54		BM	HR		E	2nd 250 sheets tray unit(2nd)(Refer to Matrix)	2nd250 枚トレイユニット	
	CCASP0009US54	1	BL	HR	N	E	2nd 250 sheets tray unit(2nd)(Refer to Matrix)	2nd250 枚トレイユニット	

20 250 枚トレイユニット (250 sheets tray unit)

Matrix

No.1-1/2	回転板 (Rotation plate)														
PARTS CODE	AR-5623N				AR-5620N				AR-5618N			AR-5620S AR-5618S			
	Germany, Switzerland, France, Spain, Italy	India, Singapore, Malaysia, Vietnam	Australia, New Zealand	Other	Germany, Switzerland, France, Spain, Italy	India, Malaysia, Vietnam	Australia, New Zealand	Other	Germany, Switzerland, France, Spain, Italy	India, Singapore, Malaysia, Vietnam	Other	Germany, Switzerland, France	India	Lebanon, Nigeria, Algeria, Egypt, Jordan, Tunisia, Morocco	Other
LPLTM0533USZZ	1st lot	1st lot	1st lot	1st lot	1st lot	1st lot	1st lot	1st lot	1st lot	1st lot	1st lot	1st lot	1st lot	1st lot	1st lot
 LPLTM0533QSZZ	Jul/11	Jul/11	Jul/11		Jul/11	Jul/11	Jul/11		Jul/11	Jul/11		Jul/11	Jul/11	Jul/11	Jul/11

No.1-2/2	回転板 (Rotation plate)														
PARTS CODE	AR-5623	AR-5620	AR-5618	AR-5623D	AR-5620D	AR-5618D	AR-5623DA	AR-5620SL							
	ALL			ALL			Argentina	ALL							
LPLTM0533USZZ	1st lot			1st lot			1st lot	1st lot							

No.4-1/2	ガイド F (Guide F)														
PARTS CODE	AR-5623N				AR-5620N				AR-5618N			AR-5620S AR-5618S			
	Germany, Switzerland, France, Spain, Italy	India, Singapore, Malaysia, Vietnam	Australia, New Zealand	Other	Germany, Switzerland, France, Spain, Italy	India, Malaysia, Vietnam	Australia, New Zealand	Other	Germany, Switzerland, France, Spain, Italy	India, Singapore, Malaysia, Vietnam	Other	Germany, Switzerland, France	India	Lebanon, Nigeria, Algeria, Egypt, Jordan, Tunisia, Morocco	Other
PGIDM0188USZZ	1st lot	1st lot	1st lot	1st lot	1st lot	1st lot	1st lot	1st lot	1st lot	1st lot	1st lot	1st lot	1st lot	1st lot	1st lot
 PGIDM0188QSZZ	Jul/11	Jul/11	Jul/11		Jul/11	Jul/11	Jul/11		Jul/11	Jul/11		Jul/11	Jul/11	Jul/11	Jul/11

No.4-2/2	ガイド F (Guide F)														
PARTS CODE	AR-5623	AR-5620	AR-5618	AR-5623D	AR-5620D	AR-5618D	AR-5623DA	AR-5620SL							
	ALL			ALL			Argentina	ALL							
PGIDM0188USZZ	1st lot			1st lot			1st lot	1st lot							

20 250 枚トレイユニット (250 sheets tray unit)

Matrix

No.5-1/2		ガイド R(Guide R)													
PARTS CODE		AR-5623N				AR-5620N				AR-5618N			AR-5620S AR-5618S		
		Germany, Switzerland, France, Spain, Italy	India, Singapore, Malaysia, Vietnam	Australia, New Zealand	Other	Germany, Switzerland, France, Spain, Italy	India, Malaysia, Vietnam	Australia, New Zealand	Other	Germany, Switzerland, France, Spain, Italy	India, Singapore, Malaysia, Vietnam	Other	Germany, Switzerland, France	India	Lebanon, Nigeria, Algeria, Egypt, Jordan, Tunisia, Morocco
PG i DM0 1 8 9 USZZ	1st lot	1st lot	1st lot	1st lot	1st lot	1st lot	1st lot	1st lot	1st lot	1st lot	1st lot	1st lot	1st lot	1st lot	1st lot
PG i DM0 1 8 9 QSZZ	Jul/11	Jul/11	Jul/11		Jul/11	Jul/11	Jul/11		Jul/11	Jul/11		Jul/11	Jul/11	Jul/11	Jul/11

No.5-2/2		ガイド R(Guide R)													
PARTS CODE		AR-5623	AR-5620	AR-5618	AR-5623D	AR-5620D	AR-5618D	AR-5623DA	AR-5620SL						
		ALL	ALL	ALL	ALL	ALL	ALL	Argentina	ALL						
PG i DM0 1 8 9 USZZ	1st lot	1st lot	1st lot	1st lot	1st lot										

No.10-1/2		軸受 R(Bearing R)													
PARTS CODE		AR-5623N				AR-5620N				AR-5618N			AR-5620S AR-5618S		
		Germany, Switzerland, France, Spain, Italy	India, Singapore, Malaysia, Vietnam	Australia, New Zealand	Other	Germany, Switzerland, France, Spain, Italy	India, Malaysia, Vietnam	Australia, New Zealand	Other	Germany, Switzerland, France, Spain, Italy	India, Singapore, Malaysia, Vietnam	Other	Germany, Switzerland, France	India	Lebanon, Nigeria, Algeria, Egypt, Jordan, Tunisia, Morocco
NBRGP0037USZZ	1st lot	1st lot	1st lot	1st lot	1st lot	1st lot	1st lot	1st lot	1st lot	1st lot	1st lot	1st lot	1st lot	1st lot	1st lot
NBRGP0037QSZZ	Jul/11	Jul/11	Jul/11		Jul/11	Jul/11	Jul/11		Jul/11	Jul/11		Jul/11	Jul/11	Jul/11	Jul/11

No.10-2/2		軸受 R(Bearing R)													
PARTS CODE		AR-5623	AR-5620	AR-5618	AR-5623D	AR-5620D	AR-5618D	AR-5623DA	AR-5620SL						
		ALL	ALL	ALL	ALL	ALL	ALL	Argentina	ALL						
NBRGP0037USZZ	1st lot	1st lot	1st lot	1st lot	1st lot										

20 250 枚トレイユニット (250 sheets tray unit)

Matrix

No.16-1/2		サハキスプリング (Separation spring)														
PARTS CODE	MSPRC0478QSAZ	AR-5623N				AR-5620N				AR-5618N			AR-5620S AR-5618S			
		Germany, Switzerland, France, Spain, Italy	India, Singapore, Malaysia, Vietnam	Australia, New Zealand	Other	Germany, Switzerland, France, Spain, Italy	India, Malaysia, Vietnam	Australia, New Zealand	Other	Germany, Switzerland, France, Spain, Italy	India, Singapore, Malaysia, Vietnam	Other	Germany, Switzerland, France	India	Lebanon, Nigeria, Algeria, Egypt, Jordan, Tunisia, Morocco	Other
		1st lot	1st lot	1st lot		1st lot	1st lot	1st lot		1st lot	1st lot		1st lot	1st lot	1st lot	

No.16-2/2		サハキスプリング (Separation spring)																		
PARTS CODE		AR-5623	AR-5620	AR-5618	AR-5623D	AR-5620D	AR-5618D	AR-5623DA	AR-5620SL											
		ALL	ALL	ALL	ALL	ALL	ALL	Argentina	ALL											

No.17-1/2		回転板ストッパー (Rotation plate stopper)														
PARTS CODE	LSTPP0020USZZ LSTPP0020QSZZ	AR-5623N				AR-5620N				AR-5618N			AR-5620S AR-5618S			
		Germany, Switzerland, France, Spain, Italy	India, Singapore, Malaysia, Vietnam	Australia, New Zealand	Other	Germany, Switzerland, France, Spain, Italy	India, Malaysia, Vietnam	Australia, New Zealand	Other	Germany, Switzerland, France, Spain, Italy	India, Singapore, Malaysia, Vietnam	Other	Germany, Switzerland, France	India	Lebanon, Nigeria, Algeria, Egypt, Jordan, Tunisia, Morocco	Other
		1st lot	1st lot	1st lot	1st lot	1st lot	1st lot	1st lot	1st lot	1st lot	1st lot	1st lot	1st lot	1st lot	1st lot	1st lot
		Jul/11	Jul/11	Jul/11		Jul/11	Jul/11	Jul/11		Jul/11	Jul/11		Jul/11	Jul/11	Jul/11	

No.17-2/2		回転板ストッパー (Rotation plate stopper)																		
PARTS CODE	LSTPP0020USZZ	AR-5623	AR-5620	AR-5618	AR-5623D	AR-5620D	AR-5618D	AR-5623DA	AR-5620SL											
		ALL	ALL	ALL	ALL	ALL	ALL	Argentina	ALL											

20 250 枚トレイユニット (250 sheets tray unit)

Matrix

No.23-1/2	取手加 [*] - (Handle cover)														
PARTS CODE	AR-5623N			AR-5620N				AR-5618N			AR-5620S AR-5618S				
	Germany, Switzerland, France, Spain, Italy	India, Singapore, Malaysia, Vietnam	Australia, New Zealand	Other	Germany, Switzerland, France, Spain, Italy	India, Malaysia, Vietnam	Australia, New Zealand	Other	Germany, Switzerland, France, Spain, Italy	India, Singapore, Malaysia, Vietnam	Other	Germany, Switzerland, France	India	Lebanon, Nigeria, Algeria, Egypt, Jordan, Tunisia, Morocco	Other
	PCOVP0114QSZ1	1st lot			1st lot			1st lot			1st lot			1st lot	

No.23-2/2	取手加 [*] - (Handle cover)														
PARTS CODE	AR-5623	AR-5620	AR-5618	AR-5623D	AR-5620D	AR-5618D	AR-5623DA	AR-5620SL							
	ALL	ALL	ALL	ALL	ALL	ALL	Argentina	ALL							
	PCOVP0114QSZ1	1st lot	1st lot	1st lot	1st lot	1st lot	1st lot	1st lot							

No.25-1/2	カセットケース (Cassette case)														
PARTS CODE	AR-5623N			AR-5620N				AR-5618N			AR-5620S AR-5618S				
	Germany, Switzerland, France, Spain, Italy	India, Singapore, Malaysia, Vietnam	Australia, New Zealand	Other	Germany, Switzerland, France, Spain, Italy	India, Malaysia, Vietnam	Australia, New Zealand	Other	Germany, Switzerland, France, Spain, Italy	India, Singapore, Malaysia, Vietnam	Other	Germany, Switzerland, France	India	Lebanon, Nigeria, Algeria, Egypt, Jordan, Tunisia, Morocco	Other
	GCASP0009USZZ	1st lot	1st lot	1st lot	1st lot	1st lot	1st lot	1st lot	1st lot	1st lot	1st lot	1st lot	1st lot	1st lot	1st lot
	GCASP0009QSZZ	Jul/11	Jul/11	Jul/11		Jul/11	Jul/11	Jul/11		Jul/11	Jul/11		Jul/11	Jul/11	Jul/11

No.25-2/2	カセットケース (Cassette case)														
PARTS CODE	AR-5623	AR-5620	AR-5618	AR-5623D	AR-5620D	AR-5618D	AR-5623DA	AR-5620SL							
	ALL	ALL	ALL	ALL	ALL	ALL	Argentina	ALL							
	GCASP0009USZZ	1st lot	1st lot	1st lot	1st lot	1st lot	1st lot	1st lot							

20 250 枚トレイユニット (250 sheets tray unit)

Matrix

No.27-1/2		カセット押し出しスプリング D(Cassette ejection spring D)														
PARTS CODE	AR-5623N				AR-5620N				AR-5618N				AR-5620S AR-5618S			
	Germany, Switzerland, France, Spain, Italy	India, Singapore, Malaysia, Vietnam	Australia, New Zealand	Other	Germany, Switzerland, France, Spain, Italy	India, Malaysia, Vietnam	Australia, New Zealand	Other	Germany, Switzerland, France, Spain, Italy	India, Singapore, Malaysia, Vietnam	Other	Germany, Switzerland, France	India	Lebanon, Nigeria, Algeria, Egypt, Jordan, Tunisia, Morocco	Other	
	MSPRC0152QSZZ	1st lot	1st lot	1st lot		1st lot	1st lot	1st lot		1st lot	1st lot		1st lot	1st lot	1st lot	

No.27-2/2		カセット押し出しスプリング D(Cassette ejection spring D)													
PARTS CODE	AR-5623	AR-5620	AR-5618	AR-5623D	AR-5620D	AR-5618D	AR-5623DA	AR-5620SL							
	ALL	ALL	ALL	ALL	ALL	ALL	Argentina	ALL							

No.29-1/2		軸受 F(Bearing F)														
PARTS CODE	AR-5623N				AR-5620N				AR-5618N				AR-5620S AR-5618S			
	Germany, Switzerland, France, Spain, Italy	India, Singapore, Malaysia, Vietnam	Australia, New Zealand	Other	Germany, Switzerland, France, Spain, Italy	India, Malaysia, Vietnam	Australia, New Zealand	Other	Germany, Switzerland, France, Spain, Italy	India, Singapore, Malaysia, Vietnam	Other	Germany, Switzerland, France	India	Lebanon, Nigeria, Algeria, Egypt, Jordan, Tunisia, Morocco	Other	
	NBRGP0036USZZ	1st lot	1st lot	1st lot	1st lot	1st lot	1st lot	1st lot	1st lot	1st lot	1st lot	1st lot	1st lot	1st lot	1st lot	
	NBRGP0036QSZZ	Jul/11	Jul/11	Jul/11		Jul/11	Jul/11	Jul/11		Jul/11	Jul/11		Jul/11	Jul/11	Jul/11	

No.29-2/2		軸受 F(Bearing F)													
PARTS CODE	AR-5623	AR-5620	AR-5618	AR-5623D	AR-5620D	AR-5618D	AR-5623DA	AR-5620SL							
	ALL	ALL	ALL	ALL	ALL	ALL	Argentina	ALL							

20 250 枚トレイユニット (250 sheets tray unit)

Matrix

No.37-1/2		カセット押え軸受 (Cassette fixing bearing)													
PARTS CODE	AR-5623N				AR-5620N				AR-5618N			AR-5620S AR-5618S			
	Germany, Switzerland, France, Spain, Italy	India, Singapore, Malaysia, Vietnam	Australia, New Zealand	Other	Germany, Switzerland, France, Spain, Italy	India, Malaysia, Vietnam	Australia, New Zealand	Other	Germany, Switzerland, France, Spain, Italy	India, Singapore, Malaysia, Vietnam	Other	Germany, Switzerland, France	India	Lebanon, Nigeria, Algeria, Egypt, Jordan, Tunisia, Morocco	Other
NBRGP0043USZZ	1st lot	1st lot	1st lot	1st lot	1st lot	1st lot	1st lot	1st lot	1st lot	1st lot	1st lot	1st lot	1st lot	1st lot	1st lot
 NBRGP0043QSZZ	Jul/11	Jul/11	Jul/11		Jul/11	Jul/11	Jul/11		Jul/11	Jul/11		Jul/11	Jul/11	Jul/11	Jul/11

No.37-2/2		カセット押え軸受 (Cassette fixing bearing)													
PARTS CODE	AR-5623 AR-5620 AR-5618	AR-5623D AR-5620D AR-5618D	AR-5623DA	AR-5620SL											
	ALL	ALL	Argentina	ALL											
NBRGP0043USZZ	1st lot	1st lot	1st lot	1st lot											

No.901-1/2		250 枚トレイユニット (250 sheets tray unit)													
PARTS CODE	AR-5623N				AR-5620N				AR-5618N			AR-5620S AR-5618S			
	Germany, Switzerland, France, Spain, Italy	India, Singapore, Malaysia, Vietnam	Australia, New Zealand	Other	Germany, Switzerland, France, Spain, Italy	India, Malaysia, Vietnam	Australia, New Zealand	Other	Germany, Switzerland, France, Spain, Italy	India, Singapore, Malaysia, Vietnam	Other	Germany, Switzerland, France	India	Lebanon, Nigeria, Algeria, Egypt, Jordan, Tunisia, Morocco	Other
CCASP0009RS53	1st lot	1st lot	1st lot		1st lot	1st lot	1st lot		1st lot	1st lot		1st lot	1st lot	1st lot	1st lot
 CCASP0009US53	Apr/11	Apr/11	Apr/11	1st lot	Apr/11	Apr/11	Apr/11	1st lot	Apr/11	Apr/11	1st lot	Apr/11	Apr/11	Apr/11	1st lot

No.901-2/2		250 枚トレイユニット (250 sheets tray unit)													
PARTS CODE	AR-5623 AR-5620 AR-5618	AR-5623D AR-5620D AR-5618D	AR-5623DA	AR-5620SL											
	ALL	ALL	Argentina	ALL											
CCASP0009US53	1st lot	1st lot	1st lot	1st lot											

20 250 枚トレイユニット (250 sheets tray unit)

Matrix

No.902	2nd250 枚トレイユニット (2nd 250 sheets tray unit)																
PARTS CODE	AR-5623N				AR-5620N				AR-5623	AR-5620	AR-5623D	AR-5620D	AR-5623DA				
	Germany, Switzerland, France, Spain, Italy	India, Singapore, Malaysia, Vietnam	Australia, New Zealand	Other	Germany, Switzerland, France, Spain, Italy	India, Malaysia, Vietnam	Australia, New Zealand	Other	ALL	ALL	ALL	ALL	Argentina				
CCASP0009RS54	1st lot	1st lot	1st lot		1st lot	1st lot	1st lot										
 CCASP0009US54	Apr/11	Apr/11	Apr/11	1st lot	Apr/11	Apr/11	Apr/11	1st lot	1st lot	1st lot	1st lot						

20 250 枚トレイユニット (250 sheets tray unit)

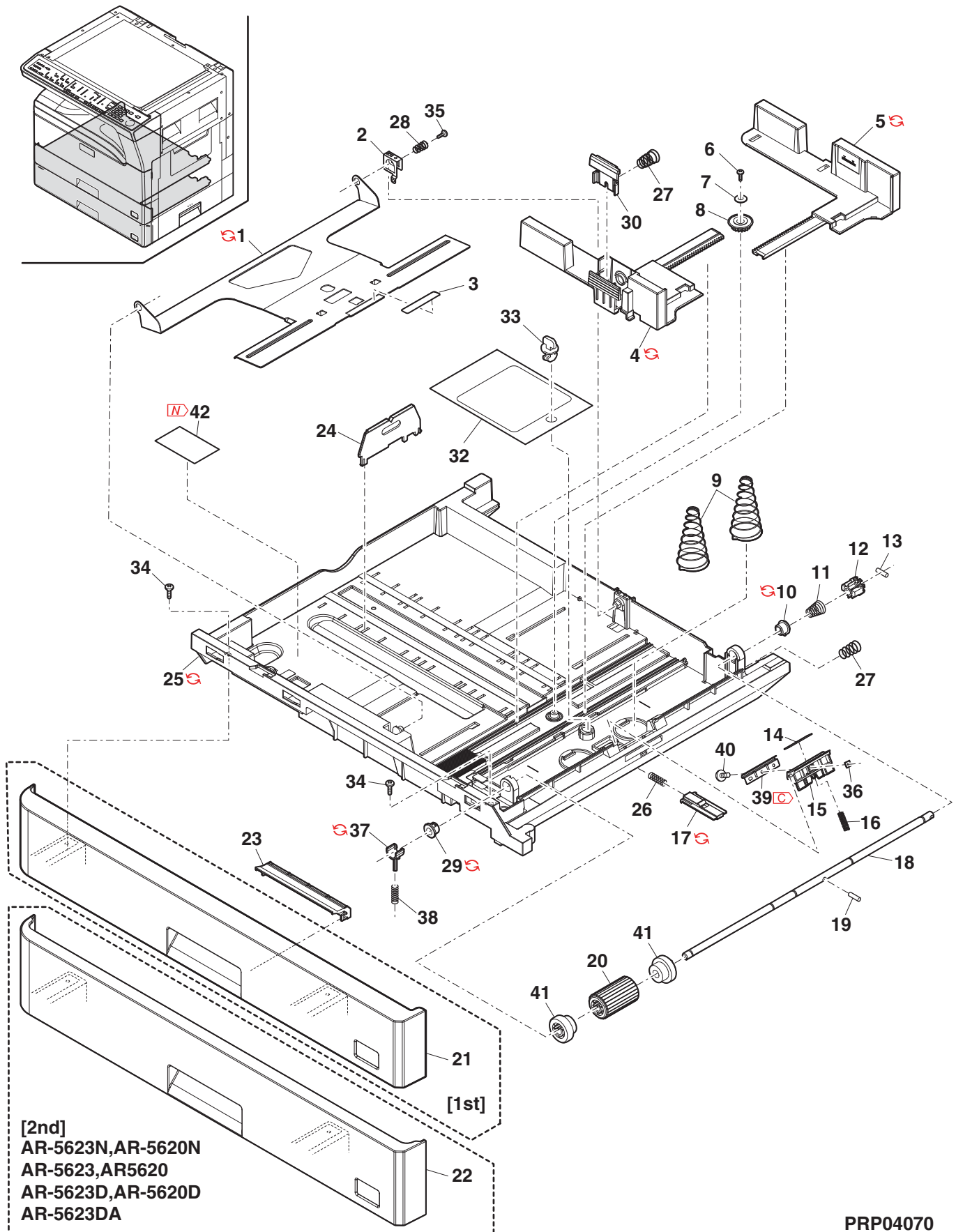

PRP04070

21 2nd トリ外装 (2nd tray exteriors)[AR-5623N/5620N/5623/5620/5623D/5623DA/5620D]

NO.	PARTS CODE	Inter-change	PRICE RANK		NEW MARK	PART RANK	DESCRIPTION	TR No.	Effective time
			Ex.	Ja.					
1	LPLTM0543QSZZ		AP	EQ		C	2nd joint plate R	2nd 連結プレートR	
2	PSHEZ0611QSZZ		AC	DJ		C	Joint plate R protect sheet	連結板 R 保護シート	
3	GGAD-0002QSZZ		AE	DS		C	Edge guard lower	エッジガード下	
5	LSUPP0083FCZZ		AB	DJ		C	PWB supporter	基板サポーター	
6	CPWBF0238QS31		BT	NE		E	1st tray interface PWB(Refer to Matrix)	1st トリ中継基板	
6	CPWBF0238US51	1	BA	FX	N	E	1st tray interface PWB(Refer to Matrix)	1st トリ中継基板	
7	DHAi-0617QSPZ		BY	TF		C	Multistage earth harness	多段階アースハーネス	
8	LBNDJ0037FCZ1		AA	DJ		C	Band	バンド	
9	XEBS740P12000		AA	DD		C	Screw(4x12)	ビス	
10	XHBS730P10000		AD	DD		C	Screw(3x10)	ビス	
11	LHLDW3142KCZZ		AC	DD		C	Cable band(TY-33M)	ケーブルバンド	
12	RCORF0046FCZZ		AH	DX		C	Ferrite core(UF-90)	フェライトコア	
13	DHAi-0556QSPZ		AT	EZ		C	CS MCU harness	CS MCU ハーネス	
14	PGiDM0194QSZZ		AR	EQ		C	1st transport PG	1st 搬送 PG	
15	NRÖLP0169QSZZ		AC	DJ		C	Right lower door follower collar	右下ドア従動コリ	
16	NSFTZ2949FCZZ		AG	DX		C	Right door follower shaft	右下ドア従動軸	
17	MSPRT0433QSZZ		AC	DJ		C	Right lower door pressure spring	右下ドア加圧スプリング	
18	LX-BZ3008SCPM		AA	DD		C	Screw	ビス	
19	MLEVP0136QSZZ		AF	DS		C	Right door lock release lever	右下ドアロック解除レバー	
20	MSPRC3402FCZZ		AC	DJ		C	Lock lever pressure spring	ロックレバー加圧スプリング	
21	NSFTZ0120QSZZ		AL	EB		C	Right lower door lock shaft	右下ドアロック軸	
22	MARMP0015QSZZ		AD	DJ		C	1st door arm	1st ドアアーム	
23	XBPS730P06000		AA	DD		C	Screw(3x6)	ビス	
24	PTME-0284FCZZ		AE	DS		C	L door lock pawl	L ドアロック爪	
25	GCOV-0090QSZZ		AS	EQ		D	1st right cover	1st 右カバー	
26	GCOV-0088QSZZ		AQ	EQ		D	Back cover	バックカバー	
27	NGERH0258QSZZ		AD	DD		C	Gear(31T)	ギヤ	
28	PRNGP0019FCZZ		AA	DD		C	V ring	V リング	
29	GLEGG0064FCZZ		AC	DJ		D	Rubber foot(Refer to Matrix)	ゴム足	
30	LPLTM0113QSZ1		AH	DX		C	Guide R joint plate	ガイド R 連結板	
31	PGiDM0192QSZZ		BD	GJ		C	Guide R	ガイド R	
32	PGiDM0191QSZZ		BC	GD		C	Guide L	ガイド L	
33	LPLTP0432QSZ1		AH	DX		C	2nd front fixing plate	2nd 前固定板	
34	XEBS740P14000		AB	DD		C	Screw(4x14)	ビス	
	(Unit)								
901	DUNT-0819RS12		BS	MW		E	2nd paper feed unit(Refer to Matrix)	[Include[22]] 2nd 給紙ユニット	
	DUNT-0819US12	1	BU	NN	N	E	2nd paper feed unit(Refer to Matrix)	[Include[22]] 2nd 給紙ユニット	

21 2nd トイ外装 (2nd tray exteriors)[AR-5623N/5620N/5623/5620/5623D/5623DA/5620D]

Matrix

No.6		1st トイ中継基板 (1st tray interface PWB)																
PARTS CODE		AR-5623N			AR-5620N													
		Germany, Switzerland, France, Spain, Italy	India, Singapore, Malaysia, Vietnam	Australia, New Zealand	Other	Germany, Switzerland, France, Spain, Italy	India, Malaysia, Vietnam	Australia, New Zealand	Other	AR-5623 AR-5620	AR-5623D AR-5620D	AR-5623DA						
	CPWBF0238QS31	1st lot	1st lot	1st lot		1st lot	1st lot	1st lot		ALL	ALL	Argentina						
	CPWBF0238US51	Apr/11	Apr/11	Apr/11	1st lot	Apr/11	Apr/11	Apr/11	1st lot	1st lot	1st lot	1st lot						

No.29		ゴム足 (Rubber foot)																
PARTS CODE		AR-5623N			AR-5620N													
		Germany, Switzerland, France, Spain, Italy	India, Singapore, Malaysia, Vietnam	Australia, New Zealand	Other	Germany, Switzerland, France, Spain, Italy	India, Malaysia, Vietnam	Australia, New Zealand	Other	AR-5623 AR-5620	AR-5623D AR-5620D	AR-5623DA						
	GLEGG0064FCZZ	1st lot	1st lot	1st lot		1st lot	1st lot	1st lot		ALL	ALL	Argentina						
		1st lot	1st lot	1st lot		1st lot	1st lot	1st lot		ALL	ALL	Argentina						

No.901		2nd 給紙ユニット (2nd paper feed unit)																
PARTS CODE		AR-5623N			AR-5620N													
		Germany, Switzerland, France, Spain, Italy	India, Singapore, Malaysia, Vietnam	Australia, New Zealand	Other	Germany, Switzerland, France, Spain, Italy	India, Malaysia, Vietnam	Australia, New Zealand	Other	AR-5623 AR-5620	AR-5623D AR-5620D	AR-5623DA						
	DUNT-0819RS12	1st lot	1st lot	1st lot		1st lot	1st lot	1st lot		ALL	ALL	Argentina						
	DUNT-0819US12	Apr/11	Apr/11	Apr/11	1st lot	Apr/11	Apr/11	Apr/11	1st lot	1st lot	1st lot	1st lot						

21 2nd トレイ外装 (2nd tray exteriors)[AR-5623N/5620N/5623/5620/5623D/5623DA/5620D]

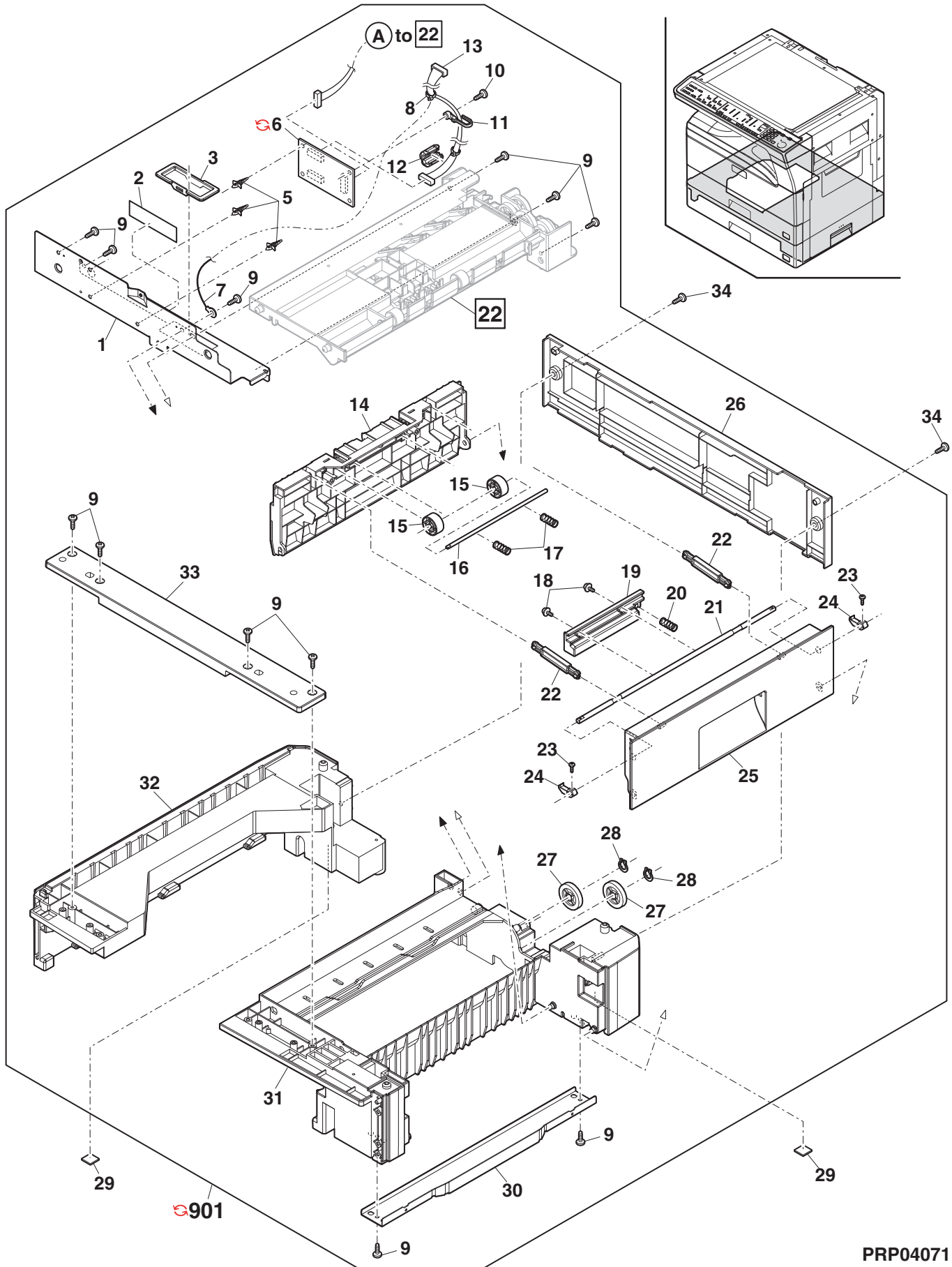

PRP04071

22 2nd トイ給紙ユニット (2nd tray paper feed unit)
 [AR-5623N/5620N/5623/5620/5623D/5623DA/5620D]

NO.	PARTS CODE	Inter-change	PRICE RANK		NEW MARK	PART RANK	DESCRIPTION	TR No.	Effective time
			Ex.	Ja.					
1	XRESP50-06000		AA	DD		C	E type ring(E5)		E リング
2	NBRGC0188FCZZ		AB	DD		C	PF bearing		PF 軸受
3	NR0LP0168QSZZ		AN	EQ		C	Transport roller		搬送ローラー
4	XPSSJ30-18000		AB	DD		C	Spring pin		スプリングピン
5	NBRGC0756FCZZ		AC	DJ		C	MG bearing DID		MG 軸受 DID
6	NSFTZ0123QSZZ		AF	DS		C	Paper feed shaft 2		給紙軸 2
7	PCLC-0035QSZ1		AZ	FQ		B	PF clutch 2		PF クラッチ 2
8	NSFTZ0122QSZZ		AE	DS		C	Paper feed shaft 1		給紙軸 1
9	NGERH0257QSZZ		AD	DJ		C	Gear(27T)		ギヤ
10	NBRGM0501FCZZ		AB	DJ		C	Bearing		軸受
11	NGERH0260QSZZ		AD	DD		C	Gear(30T)		ギヤ
12	XRESP40-06000		AA	DD		C	E type ring(E4)		E リング
13	PCLC-0036QSZ1		AZ	FQ		B	Vertical transport clutch		縦搬送クラッチ
14	LFRM-0106QSZZ		AX	FG		D	Paper feed frame		給紙フレーム
15	MSPRD0432QSZZ		AE	DJ		C	Paper feed earth spring		給紙アースリング
16	NGERH0259QSZZ		AD	DJ		C	Gear(20T)		ギヤ
17	NGERH0258QSZZ		AD	DD		C	Gear(31T)		ギヤ
18	LPLTM0538QSZZ		AD	DD		C	2nd joint earth plate		2nd 連結アース板
19	QSW-B0017QSZZ		AF	DS		B	Tray detect switch		トレイ検知スイッチ
20	MLEVP0046QSZZ		AD	DJ		C	CICS actuator		CICS アクチュエーター
21	VHPGP1A71A1-18		AG	DX		B	Photo sensor(GP1A71A1)		フォトセンサー
22	MLEVP0039QSZZ		AE	DJ		C	PPDI actuator		PPDI アクチュエーター
23	DHAi-0612QSP1		CG	UM		C	2nd cassette harness		2nd カセットハーネス
24	MSPRD0156QSZZ		AB	DJ		C	PPDI ACT return spring(PPD1ACT)		PPDI ACT 復帰スプリング
25	MSPRD0434QSZZ		AD	DJ		C	Joint arm spring		連結アースリング
26	MARMP0069QSZZ		AD	DJ		C	1st joint arm		1st 連結アーム
27	PRNGP0019FCZZ		AA	DD		C	V ring		V リング
28	NBRGM0042QSZZ		AD	DJ		C	Metal bearing D		メタル軸受 D
	(Unit)								
901	DUNT-0819RS12		BS	MW		E	2nd paper feed unit(Refer to Matrix)	[Include[21]]	2nd 給紙ユニット
	DUNT-0819US12	1	BU	NN	N	E	2nd paper feed unit(Refer to Matrix)	[Include[21]]	2nd 給紙ユニット

Matrix

No.901	2nd 給紙ユニット (2nd paper feed unit)												
PARTS CODE	AR-5623N				AR-5620N				AR-5623	AR-5620	AR-5623D	AR-5620D	AR-5623DA
	Germany, Switzerland, France, Spain, Italy	India, Singapore, Malaysia, Vietnam	Australia, New Zealand	Other	Germany, Switzerland, France, Spain, Italy	India, Malaysia, Vietnam	Australia, New Zealand	Other	ALL	ALL	Argentina		
DUNT-0819RS12	1st lot	1st lot	1st lot		1st lot	1st lot	1st lot						
DUNT-0819US12	Apr/11	Apr/11	Apr/11	1st lot	Apr/11	Apr/11	Apr/11	1st lot	1st lot	1st lot	1st lot		

22 2nd トイ給紙ユニット (2nd tray paper feed unit)
 [AR-5623N/5620N/5623/5620/5623D/5623DA/5620D]

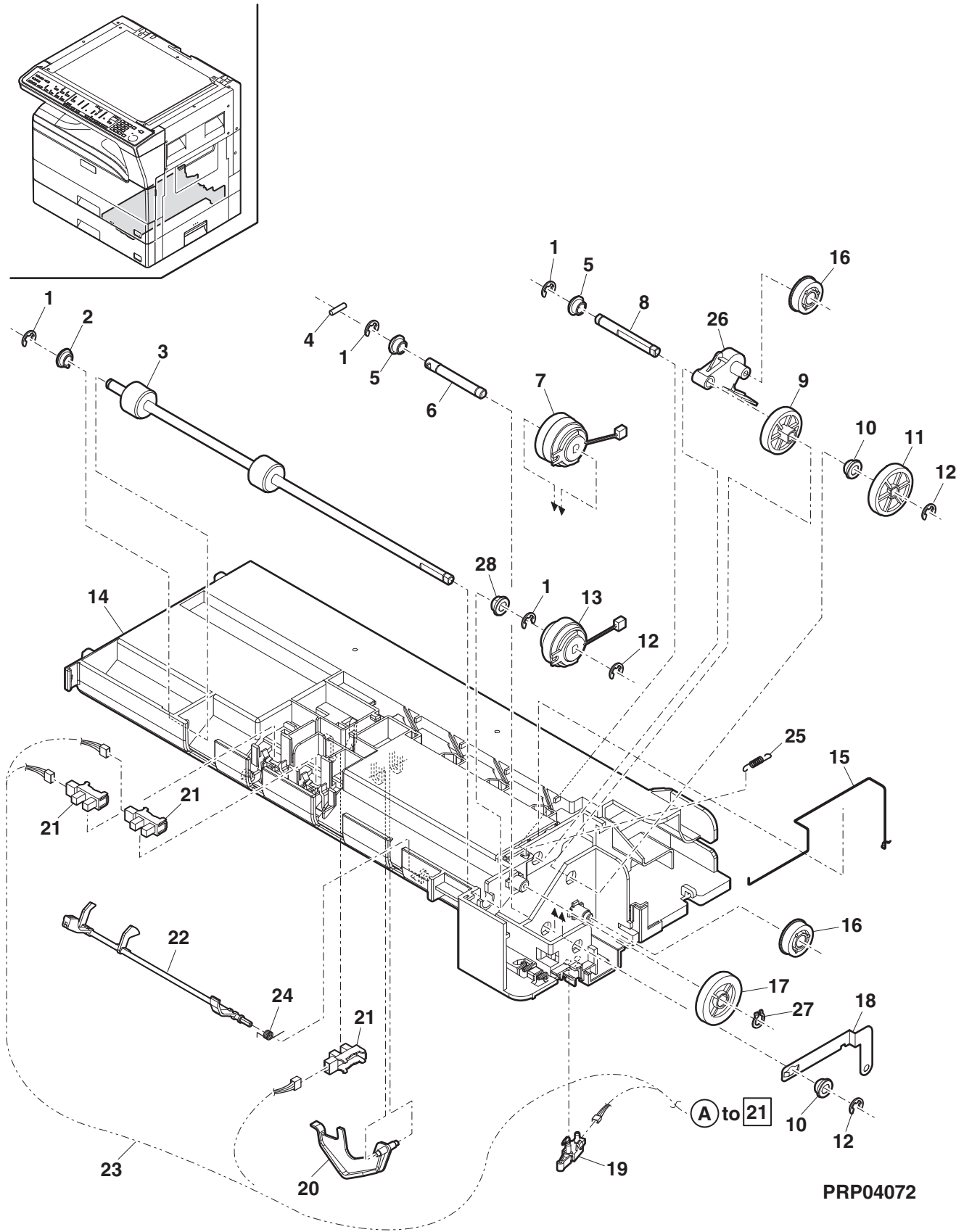

PRP04072

23 梱包材 & 付属品 (Packing material & Accessories)

NO.	PARTS CODE	Inter-change	PRICE RANK		NEW MARK	PART RANK	DESCRIPTION	TR No.	Effective time
			Ex.	Ja.					
5	SSAKZ0003QSZ1		AK	DX		D	Vinyl bag		ホリ袋
8	TCADZ0010QSZZ		AC	DJ		D	Unpacking caution card		開梱注意紙
9	LX-BZ0100QSZZ		AD	DJ		C	Optical fixing screw		光学固定ビス
12	CCL EZ0005RS51		AQ	EQ		D	Charger cleaner unit(Refer to Matrix)		チャージャークリーナ ユニット
	CCL EZ0005US51		AE	DS		D	Charger cleaner unit(Refer to Matrix)		チャージャークリーナ ユニット
13	SPAKA0736QSZZ		AE	DJ		D	Scanner reinforcement material		スキャ補強材
15	SPAKA0751QSZZ		AH	DX		D	TN packing sleeve	[India,Singapore,Malaysia, Vietnam,Thailand,Russia]	TD スリーブ
16	SPAKA0476QSZZ		AY	FQ		D	DV packing sleeve	[India,Singapore,Malaysia, Vietnam,Thailand,Russia]	DV スリーブ
22	CDSKA0291QS31		AK	DX		D	CD-ROM(Refer to Matrix)		CD-ROM
	CDSKA0292QS31		AK	DX		D	CD-ROM(Refer to Matrix)		CD-ROM
	CDSKA0295QS31		AS	EZ		D	CD-ROM(Refer to Matrix)		CD-ROM
23	TLABH0065QSZZ		AG	DX		D	Size display label	[AB series]	サイズ表示ラベル
	TLABH0069QSZZ		AG	DX		D	Size display label	[Inch series]	サイズ表示ラベル
24	SSAKA2341QCZZ		AA	DD		D	Vinyl bag(230×340)		ホリ袋
25	CPNLH0074QS02		AC	DD		D	Key sheet(Refer to Matrix)		キート
26	SSAKA2011KCZZ		AA	DD		D	Vinyl bag(60×100)(Refer to Matrix)		ホリ袋
28	Ⓢ TiNSX2162USZZ	-	AF	DS	N	D	Start guide manual(Refer to Matrix)[Missing parts code]		スタートガイド
	Ⓢ TiNSM2163USZZ	-	AP	EQ	N	D	Start guide manual(Refer to Matrix)[Missing parts code]		スタートガイド
	Ⓢ TiNSM2163USZ1	3	BA	FX	N	D	Start guide manual(Refer to Matrix) [Specification change]		スタートガイド
	TiNSX2166USZZ		AW	FG		D	Start guide manual(Refer to Matrix)		スタートガイド
	TiNSM2167USZZ		BA	FX		D	Start guide manual(Refer to Matrix)		スタートガイド
29	Ⓢ UD iSM0006USZZ	-	AS	EZ	N	D	Operation manual(Refer to Matrix) [Missing parts code]		取扱説明書
	Ⓢ UD iSM0006QSZZ	-	AK	DX	N	D	Operation manual(Refer to Matrix) [Missing parts code]		取扱説明書
	Ⓢ UD iSM0007USZZ	-	AS	EZ	N	D	Operation manual(Refer to Matrix) [Missing parts code]		取扱説明書
	UD iSM0006USZ1		AS	EZ		D	Operation manual(Refer to Matrix)		取扱説明書
	UD iSM0007USZ1		AS	EZ		D	Operation manual(Refer to Matrix)		取扱説明書
37	UBNDA0001FCZZ		AA	DD		D	AC cord band(Refer to Matrix)		ACコードタイ
	LBND C0075FCZZ		AB	DJ		D	AC cord band(Refer to Matrix)		ACコードタイ
38	SSAKA3001CCZZ		AA	DD		D	Vinyl bag(140×260)	[100V series]	ホリ袋
	SSAKA5003CCZZ		AA	DD		D	Vinyl bag(140×260)	[200V series]	ホリ袋
39	TGAN-A181WRRZ		AN	DJ		D	Warranty card	[Thailand]	保証書カード
	TGAN E1001QCZB		AC	DJ		D	SCA warranty	[Australia,New Zealand]	SCA 保証書
40	TCADZ0049QSZZ		AH	DX		D	Installation card	[Europe]	設置報告書
41	TCADZ0590QSZZ		AQ	EQ		D	GOST card	[Russia]	GOST 単ビラ

23 梱包材 & 付属品 (Packing material & Accessories)

Matrix

No.12-1/2		チャージャークリーナユニット (Charger cleaner unit)													
PARTS CODE	AR-5623N			AR-5620N			AR-5618N			AR-5620S AR-5618S					
	Germany, Switzerland, France, Spain, Italy	India, Singapore, Malaysia, Vietnam	Australia, New Zealand	Other	Germany, Switzerland, France, Spain, Italy	India, Malaysia, Vietnam	Australia, New Zealand	Other	Germany, Switzerland, France, Spain, Italy	India, Singapore, Malaysia, Vietnam	Other	Germany, Switzerland, France	India	Lebanon, Nigeria, Algeria, Egypt, Jordan, Tunisia, Morocco	Other
CCLEZ0005RS51	1st lot	1st lot	1st lot		1st lot	1st lot	1st lot		1st lot	1st lot		1st lot	1st lot	1st lot	
CCLEZ0005US51				1st lot				1st lot							1st lot

No.12-2/2		チャージャークリーナユニット (Charger cleaner unit)													
PARTS CODE	AR-5623	AR-5620	AR-5618	AR-5623D	AR-5620D	AR-5618D	AR-5623DA	AR-5620SL							
	ALL	ALL	ALL	ALL	ALL	ALL	Argentina	ALL							
CCLEZ0005US51	1st lot	1st lot	1st lot	1st lot	1st lot										

No.22-1/2		CD-ROM(CD-ROM)											
PARTS CODE	AR-5623N			AR-5620N			AR-5618N			AR-5620S AR-5618S			
	Germany, Switzerland, France, Spain, Italy, Australia, New Zealand	India, Singapore, Malaysia, Vietnam	Other	Germany, Switzerland, France, Spain, Italy, Australia, New Zealand	India, Malaysia, Vietnam	Other	Germany, Switzerland, France, Spain, Italy	India, Singapore, Malaysia, Vietnam	Other	India, Germany, Switzerland, France	Lebanon, Nigeria, Algeria, Egypt, Jordan, Tunisia, Morocco	Other	
CDSKA0291QS31										1st lot	1st lot		
CDSKA0292QS31	1st lot	1st lot		1st lot	1st lot		1st lot	1st lot					

No.22-2/2		CD-ROM(CD-ROM)													
PARTS CODE	AR-5623	AR-5620	AR-5618	AR-5623D	AR-5620D	AR-5618D	AR-5623DA	AR-5620SL							
	ALL	ALL	ALL	ALL	ALL	ALL	Argentina	ALL							
CDSKA0295QS31	1st lot	1st lot	1st lot	1st lot	1st lot										

23 梱包材 & 付属品 (Packing material & Accessories)

Matrix

No.25	キ-ツト (Key sheet)																												
PARTS CODE	AR-5623N AR-5618N	India, Malaysia, Vietnam, Singapore	India, Malaysia, Vietnam	AR-5620N	Philippines	India, Malaysia, Vietnam, Singapore	AR-5623 AR-5620	India, Malaysia, Vietnam, Singapore	AR-5618	Philippines	Mexico, LAG2	AR-5623D	India, Vietnam, Singapore	AR-5620D AR-5618D	Argentina	AR-5623DA	India, Vietnam, Singapore	AR-5620SL											
	CPNLH0074QS02																		1st lot	1st lot	1st lot	1st lot	1st lot	1st lot	1st lot	1st lot	1st lot	1st lot	1st lot

No.26	ホ-リ袋 (Vinyl bag)																												
PARTS CODE	AR-5623N AR-5618N	India, Malaysia, Vietnam, Singapore	India, Malaysia, Vietnam	AR-5620N	Philippines	India, Malaysia, Vietnam, Singapore	AR-5623 AR-5620	India, Malaysia, Vietnam, Singapore	AR-5618	Philippines	Mexico, LAG2	AR-5623D	India, Vietnam, Singapore	AR-5620D AR-5618D	Argentina	AR-5623DA	India, Vietnam, Singapore	AR-5620SL											
	SSAKA2011KCZZ																		1st lot	1st lot	1st lot	1st lot	1st lot	1st lot	1st lot	1st lot	1st lot	1st lot	1st lot

No.28	スタートガイド (Start guide manual)																		
PARTS CODE	Europe	AR-5623N AR-5618N	Other	Russia	Europe	Other	Europe	Other	Other	Europe	Other	Other	Europe	Other	Europe	Argentina	AR-5623DA	AR-5620SL	
																			1st lot
	T i N S X 2 1 6 2 U S Z Z																		
	T i N S M 2 1 6 3 U S Z Z	1st lot				1st lot		1st lot											
	T i N S M 2 1 6 3 U S Z Z 1	Apr/11		1st lot		Apr/11		Apr/11											
	T i N S X 2 1 6 6 U S Z Z								1st lot				1st lot				1st lot		
	T i N S M 2 1 6 7 U S Z Z									1st lot			1st lot		1st lot				

23 梱包材 & 付属品 (Packing material & Accessories)

Matrix

No.29-1/2		取扱説明書 (Operation manual)													
PARTS CODE	AR-5623N				AR-5620N				AR-5618N			AR-5620S AR-5618S			
	Other	India, Singapore, Malaysia, Vietnam	Australia, New Zealand	Europe, Russia	Other	India, Malaysia, Vietnam	Australia, New Zealand	Europe	Other	India, Singapore, Malaysia, Vietnam	Europe, Russia	Other	India	Lebanon, Nigeria, Algeria, Egypt, Jordan, Tunisia, Morocco	Europe
UD i SM0006USZZ	1st lot				1st lot				1st lot			1st lot			
UD i SM0006QSZZ		1st lot	1st lot			1st lot	1st lot			1st lot			1st lot	1st lot	
UD i SM0007USZZ				1st lot				1st lot			1st lot				1st lot

No.29-2/2		取扱説明書 (Operation manual)													
PARTS CODE	AR-5623 AR-5620 AR-5618		AR-5623D AR-5620D AR-5618D		AR-5623DA	AR-5620SL									
	Other	Europe	Other	Europe	Argentina	ALL									
UD i SM0006USZ1	1st lot		1st lot		1st lot										
UD i SM0007USZ1		1st lot		1st lot											

No.37		AC コード帯 (AC cord band)													
PARTS CODE	200V series	200V series	200V series												
	India, Singapore, Malaysia, Vietnam	Other	Argentina												
UBNDA0001FCZZ	1st lot		1st lot												
LBND00075FCZZ		1st lot													

23 梱包材 & 付属品 (Packing material & Accessories)

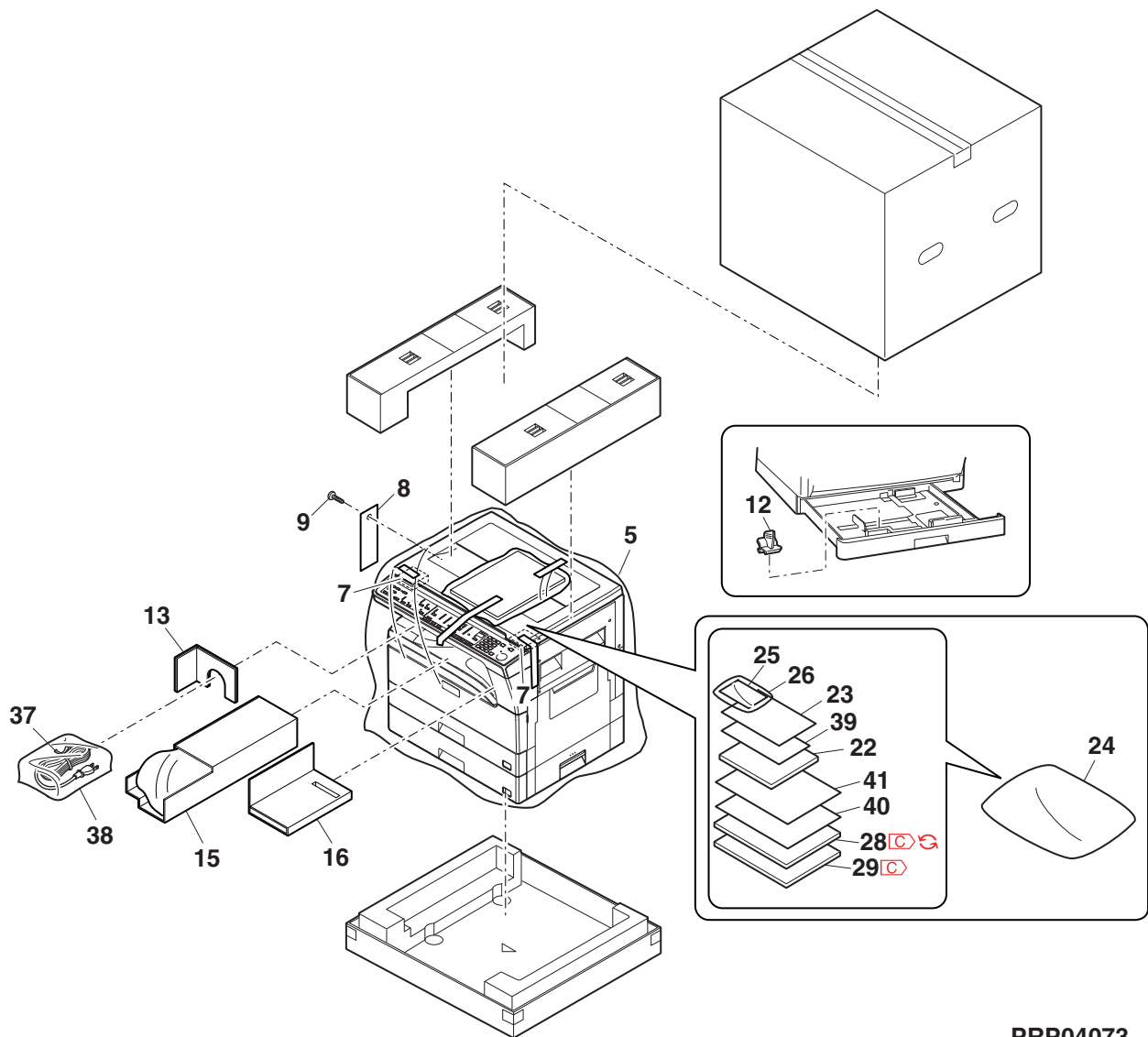

PRP04073

23 梱包材 & 付属品 (Packing material & Accessories)

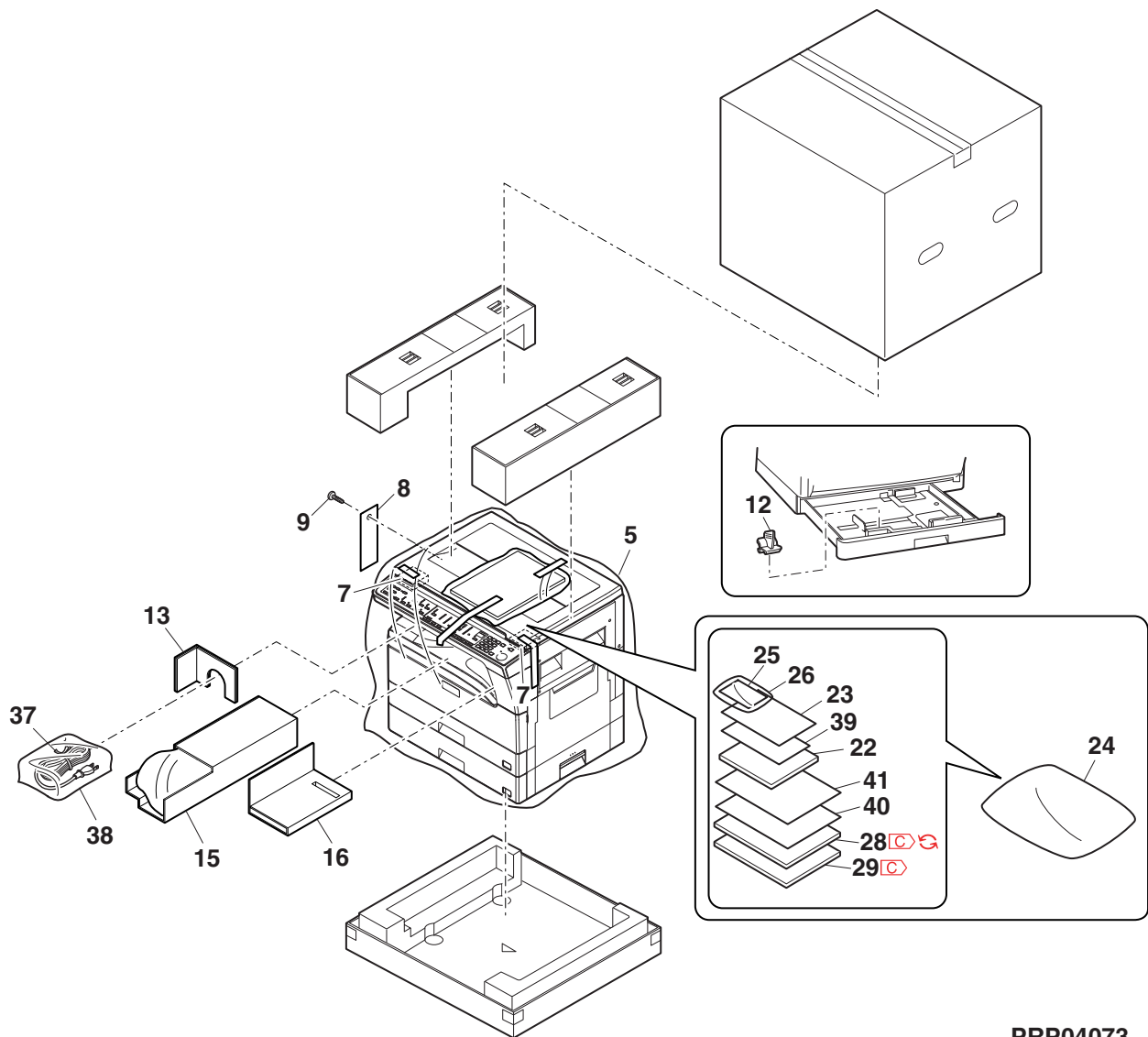

PRP04073

SHARP

COPYRIGHT © 2011 BY SHARP CORPORATION

All rights reserved.

Printed in Japan.

No part of this publication may be reproduced,
stored in a retrieval system, or transmitted.

In any form or by any means,
electronic, mechanical, photocopying, recording, or otherwise,
without prior written permission of the publisher.

SHARP CORPORATION
Document Solutions Group
CS PROMOTION CENTER
Yamatokoriyama, Nara 639-1186, Japan
2011 May Printed in Japan ⓘ